

OPERATING AND SERVICE MANUAL

**ELECTRONIC  
COUNTER  
5345A**

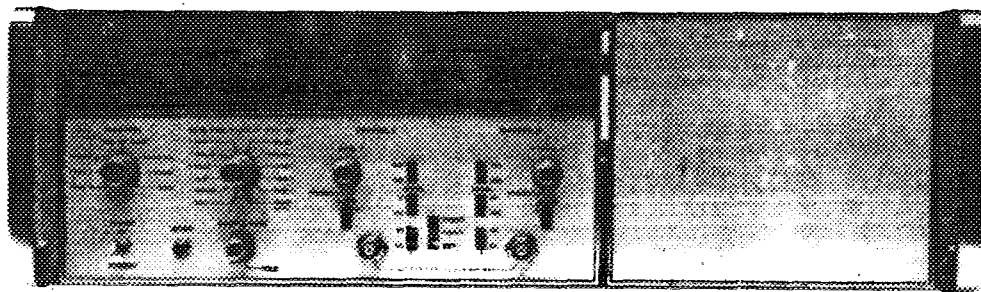

**HEWLETT  
PACKARD**

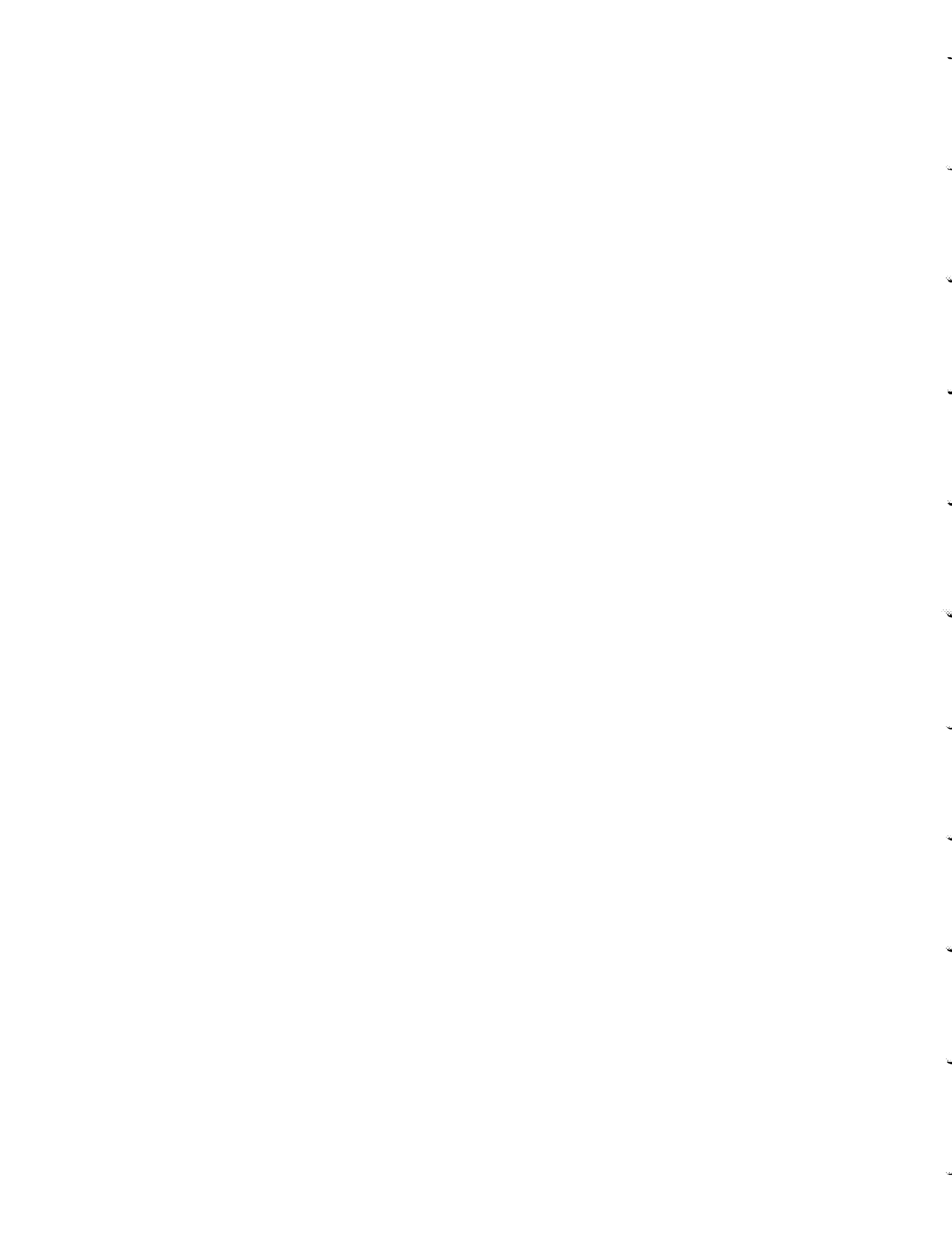

## SECTION I GENERAL INFORMATION

### 1-1. DESCRIPTION

1-2. The Hewlett-Packard Model 5345A Electronic Counter is a reciprocal counter capable of direct measurements to 500 MHz. The counter's ability to accept plug-in accessories extends its inherent capabilities and provides for a variety of additional measurements.

1-3. The instrument measures frequency, period, period average, single-shot time interval, time interval average, and ratio. It also provides a totalize function, whereby two signals can be simultaneously totalized with the displayed result being the sum of difference in the total number of counts. Using the 5245 series of plug-ins (with 10590A Adapter) extends the frequency range to 18 GHz and adds other features, such as DVM capability.

### 1-4. INSTRUMENT IDENTIFICATION AND MANUAL CHANGES

1-5. Hewlett-Packard instruments have a 2-section, 10-character serial number (0000A00000), which is located on the rear panel. The 4-digit serial prefix identifies instrument changes. If the serial prefix of your instrument differs from that listed on the title page of this manual, there are differences between this manual and your instrument. Instruments having lower serial prefixes than that listed on the title page are documented in Section VII, and higher serial prefixes are covered with manual change sheets included with the manual. If the change sheet is missing, contact the nearest Hewlett-Packard Sales and Service Office listed on the inside rear cover of this manual.

### 1-6. OPTIONS

1-7. The following is a list of available options: Option 001, 10 MHz, Voltage Controlled Oscillator; Option 010, General Purpose Interface Output (Digital Output only, HP-IB format); Option 011, General Purpose Interface I/O (provides digital output and input control over all functions except input amplifier); Option 012, similar to Option 011 but includes slope and level control. Option 908 Rack Mounting Kit is available, at additional cost, when ordered at the same time as the instrument.

### 1-8. ACCESSORIES

1-9. Table 1-1 list equipment supplied and Table 1-2 list accessories available.

Table 1-1. Equipment Supplied

Description	HP Part No.
Detachable Power Cord 231 cm (7-1/2 feet long)	8120-1378

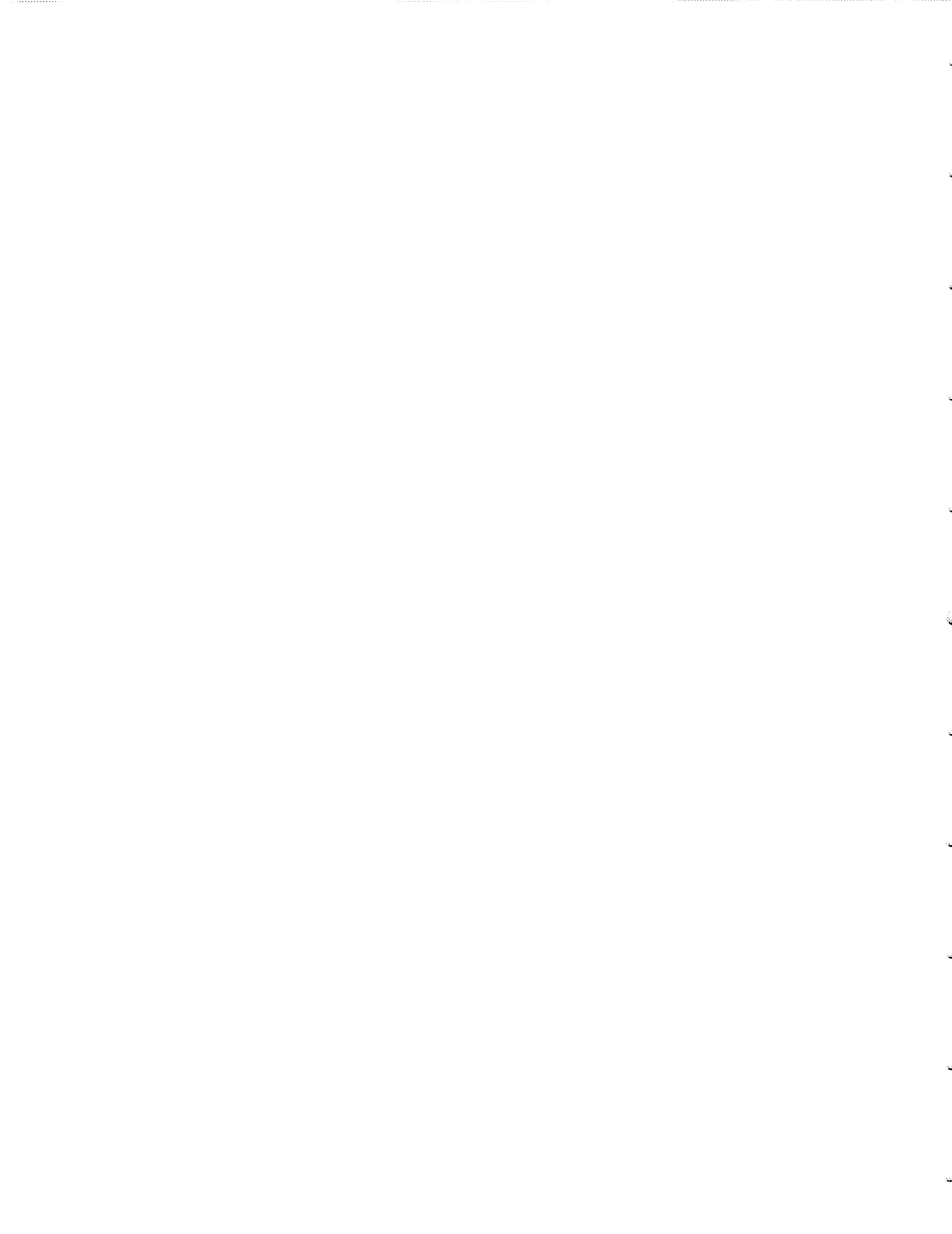

Table 1-2. Accessories Available

Description	HP Part Number
Automatic Frequency Converter (15 MHz to 4 GHz)	5345A
Rack Mounting Kit	5060-8740
Plug-In Adapter (for 5245 series plug-ins)	10590A
ASCII-to-Parallel Converter (Converts ASCII coded data to printer format)	59301A
Numeric Display (provides auxillary display)	59304A
Relay Actuator (relay switching controlled manually or by ASCII codes)	59306A
VHF Switch (allows two VHF signals to switch from one input to one of our outputs or vice versa. Controlled manually or by ASCII codes.)	59307A
Digital-to-Analog Converter	59303A
Marked Card Programmer (programs counter with marked sense cards)	3260A
I/O Card for 2100 Computer	59310A
Interface Cables (3, 6, and 12 feet, respectively)	10631A/B/C
Calculator (used as controller to program counter)	9820A or 9830A
Digital Recorder (provides printed copy of counter's data)	5050B or 5055A
Digital Recorder Interconnect Cable	562A-16C
Board Extender Kit	10595A
Replacement Board Kit	10597A
<b>5245 Series Plug-Ins</b>	
Frequency Converter (20-100 MHz, 50 mV rms sensitivity)	5251A
Prescaler (DC - 350 MHz, 100 mV rms sensitivity)	5252A
Frequency Converter (50-512 MHz, 50 mV rms sensitivity)	5253B
Frequency Converter (150 MHz - 3 GHz, 50 mV rms sensitivity)	5254C
Frequency Converter (3-12.4 GHz, 100 mV rms sensitivity)	5255A
Frequency Converter (8-18 GHz, 100 mV rms sensitivity)	5256A
Transfer Oscillator (.05-18 GHz, 100 mV rms; .05-15 GHz, 140 mV rms, 15-18 GHz)	5257A
Sensitive Prescaler (1-200 MHz, 1 mV rms sensitivity)	5258A
Video Amplifier (10 Hz - 50 MHz, 1 mV rms sensitivity)	5261A
Time Interval (1 $\mu$ s - 2x10 <sup>4</sup> sec, 0.1 $\mu$ s resolution)	5262A
Digital Voltmeter (10V, 100V, 1000V fullscale; 100 $\mu$ V resolution)	5265A
Time Interval (100 ns to 2x10 <sup>4</sup> sec., 12 ns resolution)	5267A

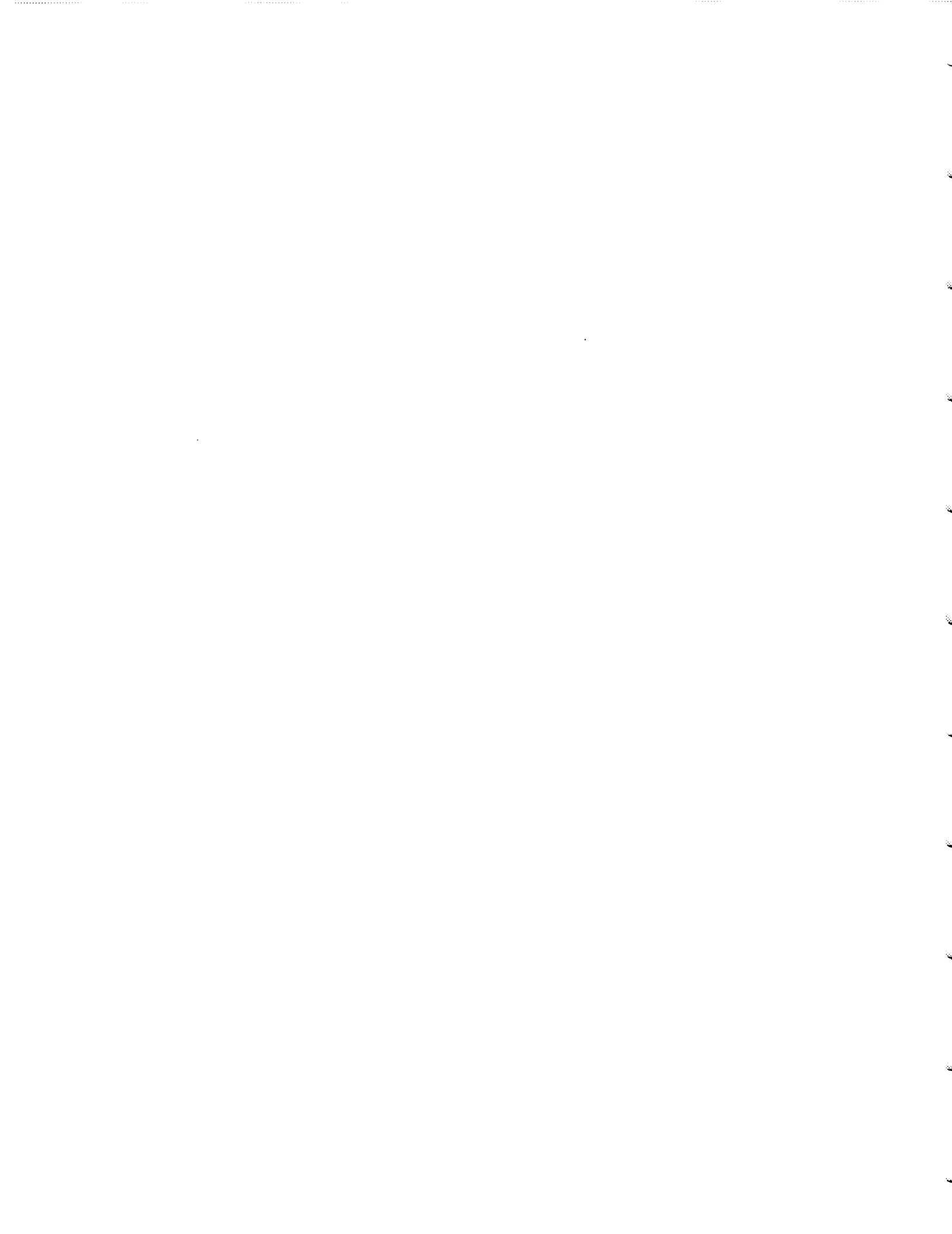

Table 1-3. Specifications

**FREQUENCY/FREQUENCY AVERAGE**

**PERIOD/PERIOD AVERAGE MEASUREMENTS**

Both frequency and period are measured by measuring the total elapsed time T, for an integral number of cycles, N, of the input waveform. Computation, involving the quantities of N and T, provides direct readout of either frequency or period.

**Range:** 50  $\mu$ Hz to 500 MHz; 2 nsec to 20,000 seconds

**Measurement Time:** Consists of GATE TIME plus the time required to reach the next STOP trigger level. When in MIN the GATE TIME is less than 50 nanoseconds. When in a decade step, the counter will reset if a stop trigger level is not reached within approximately 3.4 times the GATE TIME setting. Decade GATE TIME ranges from 100 nsec to 1000 sec.

When using EXT GATE the measurement time consists of the GATE TIME divided by the duty cycle of the EXT GATE signal plus the time required to reach the next STOP trigger level after the end of the last EXT GATE pulse.

**Accuracy:** Resolution is nine digits per second of measurement time. With DISPLAY POSITION switch in AUTO the least significant digit error is  $\pm 1$  count if the most significant digit is 1 through 4, and  $\pm 2$  counts if the most significant digit is 5 through 9. Accuracy is  $\pm$  least significant digit (LSD) counts  $\pm$  time base accuracy  $\pm$  trigger error.\*

**TIME INTERVAL/TIME INTERVAL AVERAGE**

**Range:** 10 nsec to 20,000 sec

**Minimum Time Between Trigger Points:** 10 nsec

**Trigger Pulse Width:** 1 nsec minimum width input at minimum voltage input.

**Accuracy:**

Time Interval:  $\pm$  trigger error\*\*  $\pm 2$  ns  $\pm$  time base accuracy

Time Interval Averaging:

$\pm \frac{\text{trigger error}^{**} \pm 2 \text{ nsec}}{\sqrt{\text{intervals averaged}}} \pm .7 \text{ nsec} \pm \text{time base accuracy}$

Not affected by harmonics of clock frequency.

**Resolution:**

Time Interval: 2 nsec

Time Interval Average:

$\pm \frac{2 \text{ nsec}}{\sqrt{\text{intervals averaged}}} \pm 2 \text{ picoseconds}$

**Measurement Time:** For single time interval measurements the GATE TIME switch should be in MIN. Measurement time will be the displayed time interval.

When a decade GATE TIME is selected, the counter will be in the TIME INTERVAL AVERAGE mode. The GATE TIME selected should be greater than the displayed time interval. The measurement time is now the GATE TIME divided by the duty cycle of the time interval waveform plus the time required to reach the next trigger stop level after the total GATE TIME has been accumulated.

\*Trigger error for sine waves of 40 dB signal-to-noise amplitude ratio is  $< (\pm 0.3\%$  of one period  $\pm$  number of periods averaged). If peak noise amplitude is greater than 10 millivolts, additional miscounting may occur (this situation can arise when measuring high-level outputs of broadband synthesized signal sources).

\*\*For any wave shape, trigger error is less than

$$\pm \frac{0.0025}{\text{signal slope in } V/\mu\text{s}} \mu\text{s (with 40 dB S/N) or}$$

$$\pm \frac{2 \times \text{peak noise voltage}}{\text{signal slope in } V/\mu\text{s}} \mu\text{s}$$

**RATIO B/A**

**Range:** Both channels accept dc to 500 MHz

**Accuracy:**  $\pm$  LSD  $\pm$  trigger error\* (applies only to channel A). LSD is as described under FREQUENCY ACCURACY.

**Measurement Time:** Measurement time is equal to the GATE TIME selected times 500 MHz/frequency of Channel B input.

**START/STOP**

**Range:** Both inputs may have repetition rates from dc to 500 MHz.

**Modes:** A, A+B, and A-B is determined by a rear panel switch.

**Resolution:** Not affected by GATE TIME setting. Resolution is one count up to eleven digits.

**Accuracy:** Coincident pulses may be applied to both inputs. One count is required to initiate each input, i.e., in Mode A add one count to display, in Mode A+B add two counts to display, in Mode A-B add no counts to display.

**SCALING**

**Range:** dc to 500 MHz

**Scaling Factor:** Selectable by GATE TIME setting. As GATE TIME is varied from the 100 ns position to the 1000 s position, scaling factor increases from  $10^2$  to  $10^{12}$ . Actual scaling factor equals GATE TIME setting  $\times 10^{-9}$  seconds.

**Input:** Input signal through Channel A.

**Output:** Output frequency equals input frequency divided by scaling factor. Rear panel BNC supplies 80% duty cycle TTL compatible pulses.

**INPUT CHANNELS A AND B SEPARATE INPUTS**

**Range:** DC coupled, 0 to 500 MHz

AC coupled, 1 M $\Omega$  200 Hz to 500 MHz

50 $\Omega$  4 MHz to 500 MHz

**Impedance:** Switch selectable, 1 M $\Omega$  shunted by less than 30 pF or 50 $\Omega$  nominal

**Sensitivity: (preset)**

X1 20 mV rms sine wave, 60 mV p-p pulse

X10 200 mV rms sine wave, 600 mV p-p pulse

**Dynamic Range: (preset)**

50 $\Omega$  X1 20 mV to 250 mV rms sine wave  
60 mV to 750 mV p-p pulse

X10 200 mV to 2.5V rms sine wave  
600 mV to 7V p-p pulse

1 M $\Omega$  X1 20 mV to 250 mV rms sine wave  
60 mV to 750 mV p-p pulse

X10 200 mV to 2.5V rms sine wave  
600 mV to 7.5V p-p pulse

**Linear Operating Range:** -2.0 to +0.5 Vdc

**Trigger Level:** Continuously adjustable over  $\pm 1.3$  Vdc. Adjustment is nonlinear with more settability around zero volts.

**Preset:** Centers trigger level about dc at 25 $^{\circ}$ C

**Drift:**  $\pm 10$  mV dc max., 0 $^{\circ}$ C to 55 $^{\circ}$ C

**Output:** CHAN A and CHAN B output trigger voltage (X ATTEN) is accurate to within  $\pm 15$  mV (X ATTEN) of actual trigger point hysteresis center. Rear BNC connectors.

**Slope:** Independent selection of positive or negative slope.

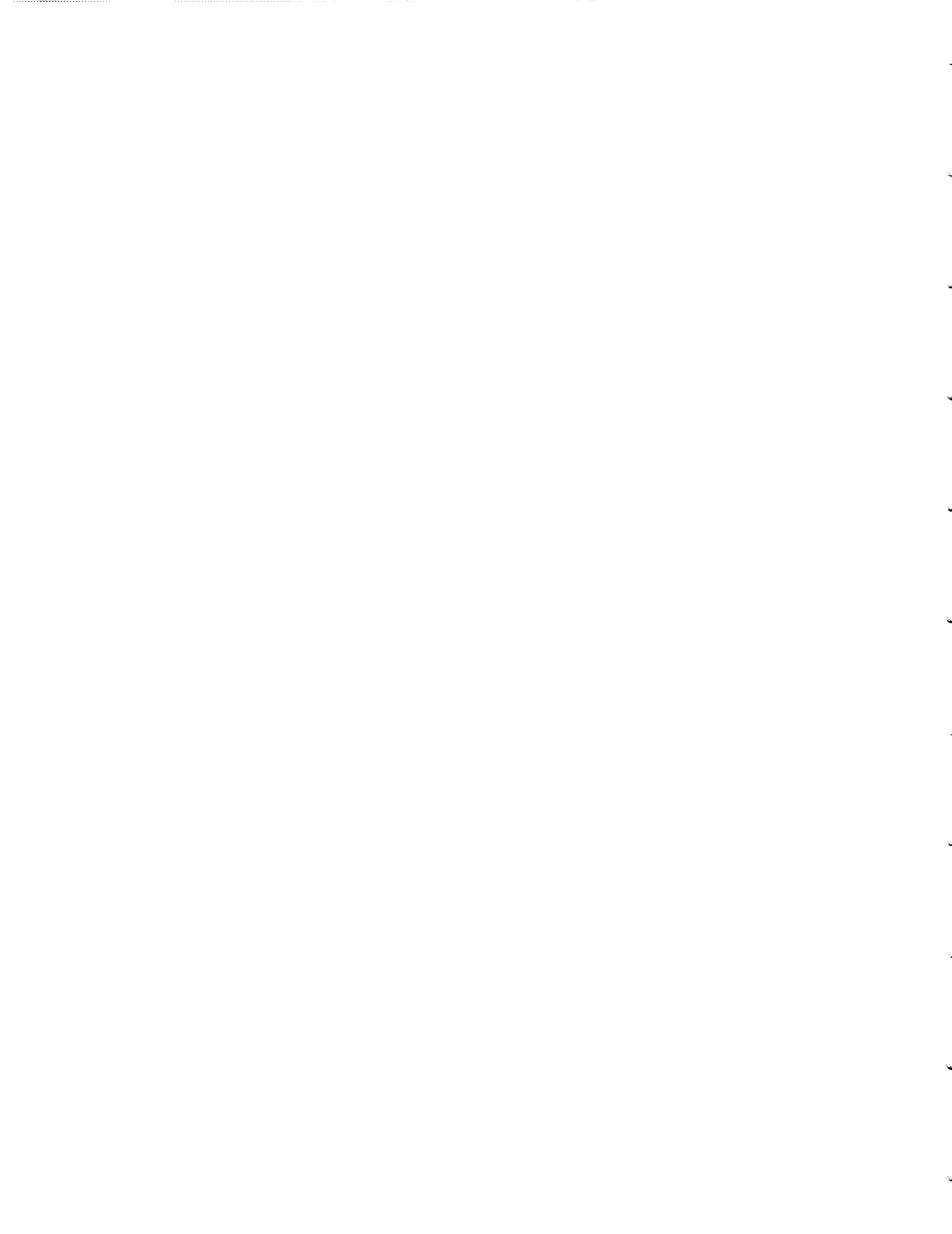



Table 1-3. Specifications (Continued)

**Maximum Input:** Damage may occur beyond specified level. For larger inputs voltage divider probes 10020A for 50 $\Omega$  and 10004B for 1 M $\Omega$  are recommended.

50 $\Omega$ X1	$\pm 7V$ dc 7V rms below 5 MHz 3.5V rms (+24 dBm) above 5 MHz
X10	$\pm 7V$ dc, 7V rms (+30 dBm)
1 M $\Omega$ X1	$\pm 350V$ dc 250V rms to 20 kHz 3.5V rms to above 5 MHz
X10	$\pm 350V$ dc 250V rms to 20 kHz 35V rms above 5 MHz

**Cross Talk:** No effects if inputs to Channel A and B are both above or below 100 MHz. With one signal above 100 MHz and the other below, there are no effects if the lower frequency signal has a slew rate of  $>10V/\mu s$ .

**COMMON INPUT**

In this mode the signal is applied to Channel A through a power splitter which equalizes impedances and delays to the input amplifiers. Channel B input is disabled. Both input impedance switches should be in the same position. All specifications are the same as for separate operation with the following differences.

**Range:** DC coupled, 0 to 400 MHz  
AC coupled, 1 M $\Omega$  300 Hz to 400 MHz  
50 $\Omega$  4 MHz to 400 MHz

**Impedance:** 1 M $\Omega$  becomes 500 k $\Omega$  shunted by  $<50$  pF  
50 $\Omega$  no change

**Sensitivity: (preset)**

50 $\Omega$ X1	40 mV rms sine wave, 120 mV p-p pulse
X10	400 mV rms sine wave, 1.2V p-p pulse
1 M $\Omega$	no change

**Dynamic Range: (preset)**

50 $\Omega$ X1	40 mV to 500 mV rms sine wave 120 mV to 1.5V p-p pulse
X10	400 mV to 5V rms sine wave, 1.2 to 5V p-p pulse
1 M $\Omega$	no change

**Maximum Input:**

50 $\Omega$	$\pm 5.0V$ dc and 5V rms
1 M $\Omega$	no change

**Trigger Level:** Continuously adjustable over the range of  $\pm 2.6$  Vdc in 50 $\Omega$  or  $\pm 1.3V$  dc in 1 M $\Omega$  multiplied by the attenuator setting.

**Output: Rear BNC Connector**

50 $\Omega$	Output voltage X2 (X ATTEN) is accurate to within $\pm 15$ mV X2 (X ATTEN) of actual trigger point.
1 M $\Omega$	Same as in SEPARATE.

**GENERAL**

**Display:** 11 digit LED display and sign. Annunciator displays ksec to nsec, k to n,  $\mu$ Hz to GHz. Decimal point is positioned with DISPLAY POSITION control or positioned after the first, second, or third most significant digit if DISPLAY POSITION is in AUTO. Leading zeros are suppressed.

**Overflow:** Asterisk is illuminated when display is overflowed or underflowed.

**Sample Rate:** Continuously variable from  $<0.1$  sec to  $>5$  sec with front panel control. In HOLD position the last reading is maintained until the counter is manually reset or an EXTERNAL ARM signal is applied. Number of readings per second will generally be limited by the output

device, i.e., 5150A Printer or 9830A Calculator. In COMPUTER DUMP mode the counter can take up to several thousand readings per second.

**External Arm Input:** Arming will be initiated by  $-1.0V$  ( $-5.0$  V max) into 50 $\Omega$  rear BNC input for greater than 500 ns. Minimum time between EXT ARM and acceptance of start pulse is  $<1$   $\mu s$ .

**External Gate Input:** EXT GATE feature will respond to a  $0.0V$  to  $-1.0V$  pulse into 50 $\Omega$  with 50 ns or faster rise and fall time pulse edges. Maximum pulse height (damage level) is  $-5V$ . Minimum pulse width is 20 ns. Time delay of the leading edge of EXT GATE to the acceptance of input signal is less than 20 ns.

**Gate Output:**  $>1$  volt into 50 $\Omega$ .

**Reset:** Counter resets at initial turn on. Can be reset at any time with front panel pushbutton or through HP Interface Bus.

**TIMEBASE**

**Standard High Stability Timebase:** Crystal Frequency, 10 MHz Oven Oscillator (10544A). (See separate data sheet).

**Stability:**

Aging Rate:  $<5 \times 10^{-10}$ \* per day  
Short Term:  $<1 \times 10^{-11}$  for 1 s average  
Temperature:  $<7 \times 10^{-9}$ , 0 $^{\circ}C$  to 55 $^{\circ}C$   
Line Voltage:  $<1 \times 10^{-10}$ \*\*,  $\pm 10\%$  from nominal

**External Frequency Standard Input:** 1, 2, 2.5, 5, or 10 MHz  $\pm 5 \times 10^{-8}$ . Input voltage  $>1$  V rms into 1 k $\Omega$ .

\*For Oscillator off time less than 24 hours.

\*\*15 minutes after change.

**Option 001:** Crystal Frequency, 10 MHz

**Stability:**

Aging Rate:  $<3 \times 10^{-7}$  per month  
Short Term:  $<2 \times 10^{-9}$  rms for 1 s average  
Temperature:  $<2 \times 10^{-6}$ , 25 $^{\circ}C$  to 35 $^{\circ}C$   
 $<5 \times 10^{-6}$ , 0 $^{\circ}C$  to 55 $^{\circ}C$

Line Voltage:  $<1 \times 10^{-8}$ ,  $\pm 10\%$  from nominal

**External Frequency Standard Input:** 1, 2, 2.5, 5, or 10 MHz  $\pm 5 \times 10^{-8}$ . Input voltage  $>1$  Vrms into 1 k $\Omega$ .

**Frequency Standard Output:** 10 MHz 1 Vrms high purity sine wave from 50 $\Omega$  source.

**Operating Temperature:** 0 $^{\circ}C$  to 55 $^{\circ}C$

**Power Requirements:** 100/120/220/240 Vrms  $+5\%$   $-10\%$ , 48 to 66 Hz, maximum power 250 VA.

**Weight:** 37 lbs (17 kg) net

**OPTIONS**

**Option 001:** Room temperature time base (room temperature crystal).

**Option 010:** Digital Output only. HP Interface Bus format, useful with 5150A Printer or 59301A with 5050B Printer.

**Option 011:** Digital Input/Output. Full compatibility with HP Interface Bus. Provides digital output as well as input for control over all functions except input amplifier.

**Option 012:** Similar to Option 011 but includes slope and level control. Recommended for computer or dedicated calculator applications. Programming codes differ slightly from Option 011. See 5345A Option 012 Technical Data Sheet for full specifications.

**Option 908:** Rack Mounting Kit

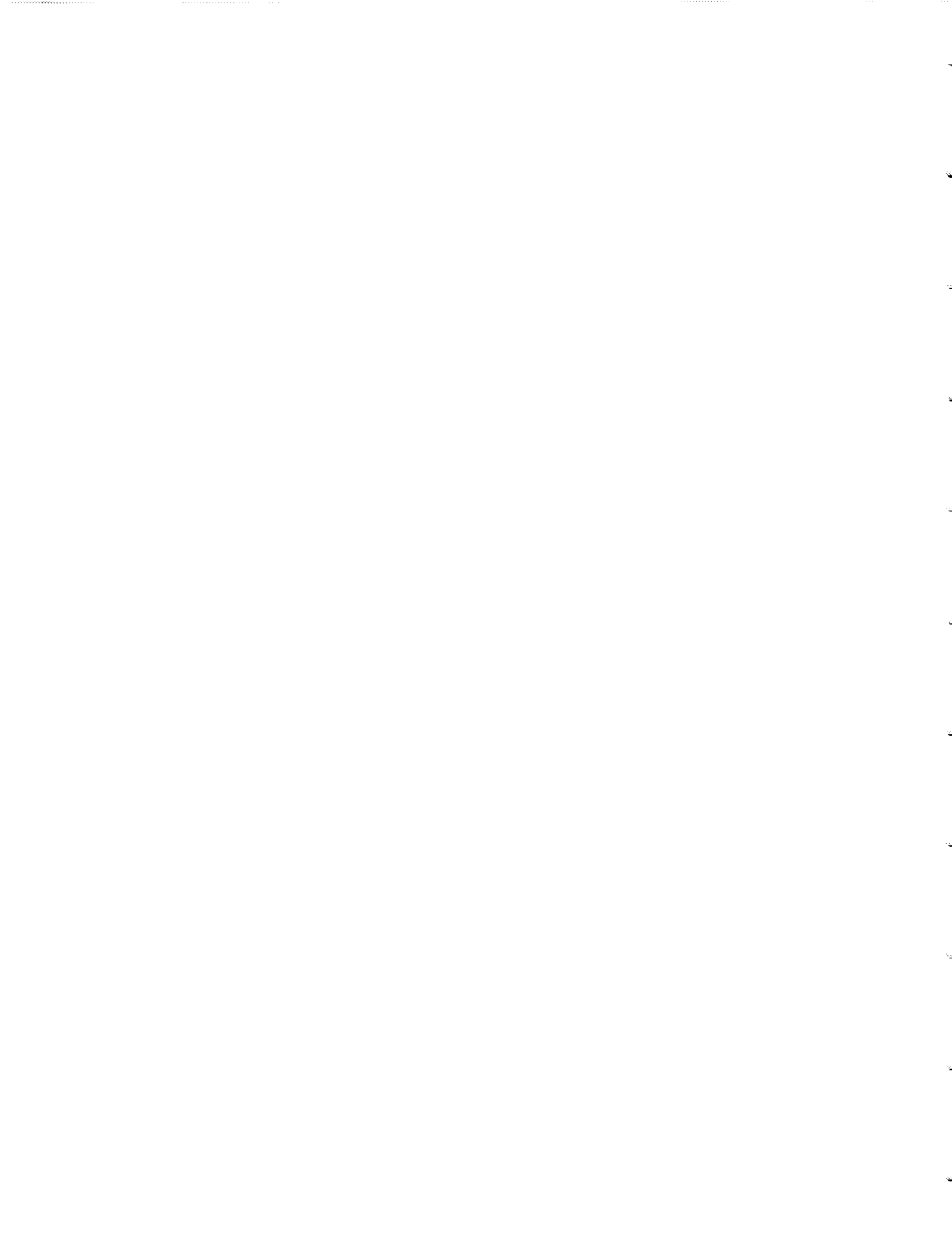

Table 1-3. Specifications (Continued)

**SELF-TEST**

A 100 MHz is internally applied for testing all functions. Pushing RESET illuminates all segments of display digits. Seven internal diagnostic switches are provided for verifying the operation of the input amplifiers, digital front-end, processor, and plug-ins.

**ACCESSORIES AVAILABLE**

**K13-59992A ASM Tester:** Useful for troubleshooting Algorithmic State Machine processor

**10595A Board Extender Kit:** Useful for troubleshooting plug-in boards while in operation.

**10590A Plug-In Adapter:** Increases usefulness of 5345A by providing interface to 5245L plug-ins. Except as noted, the plug-ins listed below operate in a manner as they do in the 5245L. Measurements taken with the plug-in adapter combination yield similar accuracy, and greater speed and resolution than is associated with the 5245 series counters. Compatible plug-ins: 5251A, 5252A (lower frequency limit 1 MHz), 5253B, 5254C, 5255A, 5256A, 5257A, 5258A, 5261A (lower frequency limit 1 MHz), 5262A, 5265A, 5257A.

**10004B:** 50Ω Probe Kit

**10020A:** 10 MΩ Probe Kit

**K15-59992A STANDBY POWER UNIT**

Plug-in to maintain oscillator operation for prolonged periods without line voltage.

**WEIGHT:** 7.2 kg (3 lbs. 4 oz.) net

**DIMENSIONS:**

**NOTES:**

DIMENSIONS IN INCHES AND (MILLIMETERS)

- Ⓐ EIA RACK HEIGHT (INCLUDING FILLER STRIP); FOR CABINET HEIGHT (INCLUDING FEET) ADD  $\frac{5}{16}$  (8) TO EIA RACK HEIGHT
- Ⓑ REAR APRON RECESS

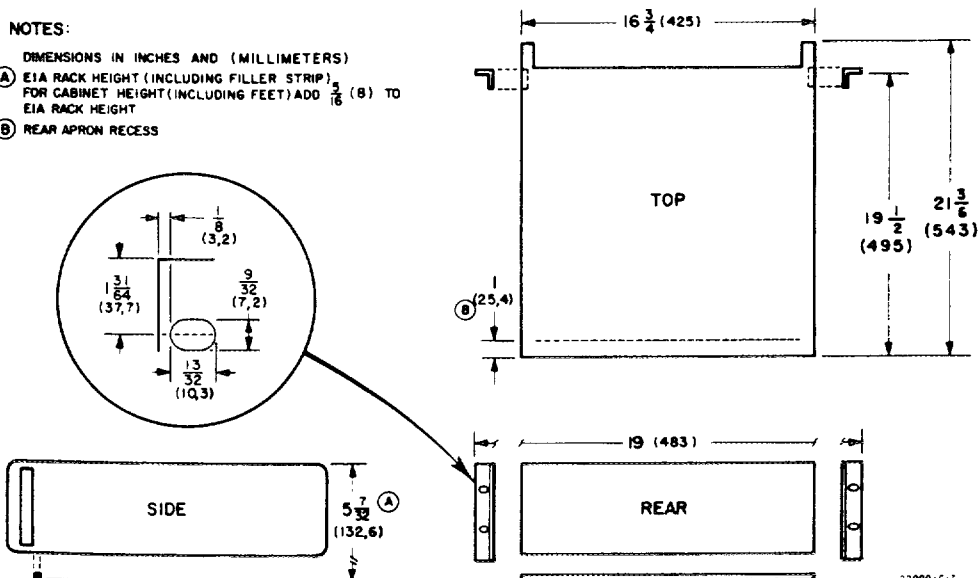

00000-C-1

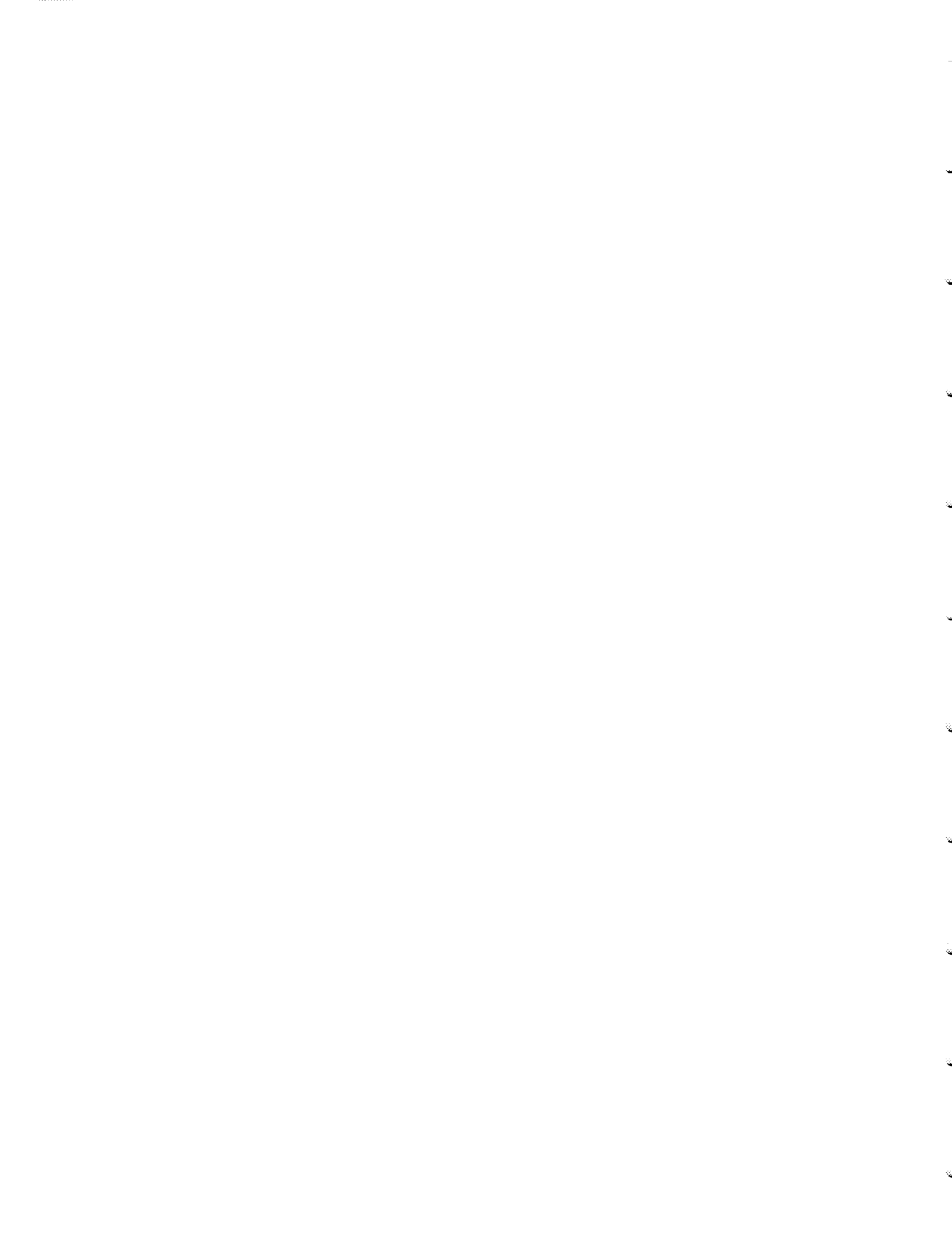

## SECTION II INSTALLATION AND REMOTE PROGRAMMING

### 2-1. INTRODUCTION

2-2. This section contains information for unpacking, inspection, storage, and installation. Also included in this section are the instructions for remote programming.

### 2-3. UNPACKING AND INSPECTION

2-4. If the shipping carton is damaged, inspect the counter for visible damage (scratches, dents, etc.). If the counter is damaged, notify the carrier and the nearest Hewlett-Packard Sales and Service Office immediately (offices are listed at the back of this manual). Keep the shipping carton and packing material for the carrier's inspection. The Hewlett-Packard Sales and Service Office will arrange for repair or replacement of your instrument without waiting for the claim against the carrier to be settled.

### 2-5. INSTALLATION REQUIREMENTS

#### CAUTION

**BEFORE CONNECTING THE INSTRUMENT TO AC POWER LINES, BE SURE THAT THE VOLTAGE SELECTOR IS PROPERLY POSITIONED AS SHOWN IN THE FIGURE BELOW.**

2-6. **LINE VOLTAGE REQUIREMENTS.** The 5345A is equipped with a printed-circuit line voltage selector to select 100, 120, 220, or 240-volt ac operation. Before applying power, the pc selector must be set to the correct position and the correct fuse must be installed as shown below. (Fuses are 100/120V, 2.5 AT; 220/240V, 1.25 AT.)

PC BOARD PART NUMBER IS  
HP 5020-8122

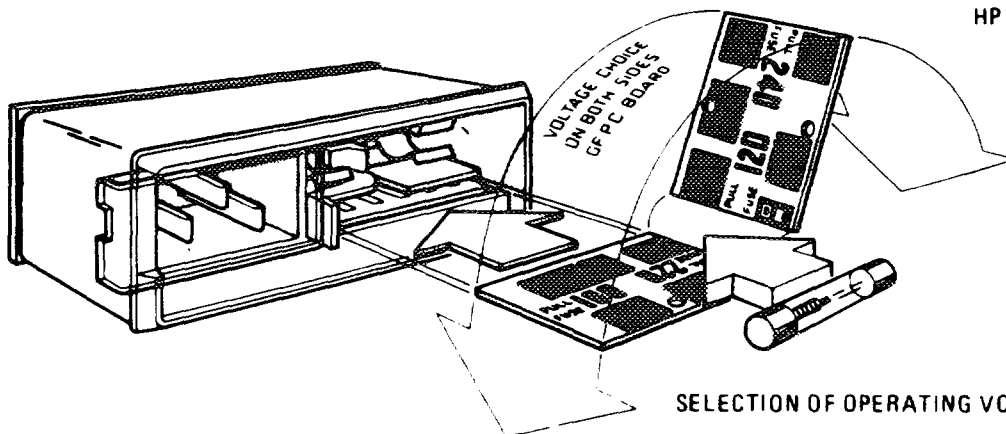

#### SELECTION OF OPERATING VOLTAGE

Operating voltage is shown in module window.

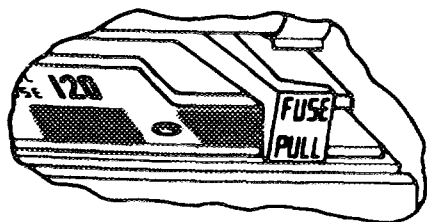

1. Open cover door and rotate fuse-pull to left.
2. Select operating voltage by orienting PC board to position desired voltage on top-left side. Push board firmly into module slot.
3. Rotate fuse-pull back into normal position and re-insert fuse in holders, using cautions to select correct fuse value.

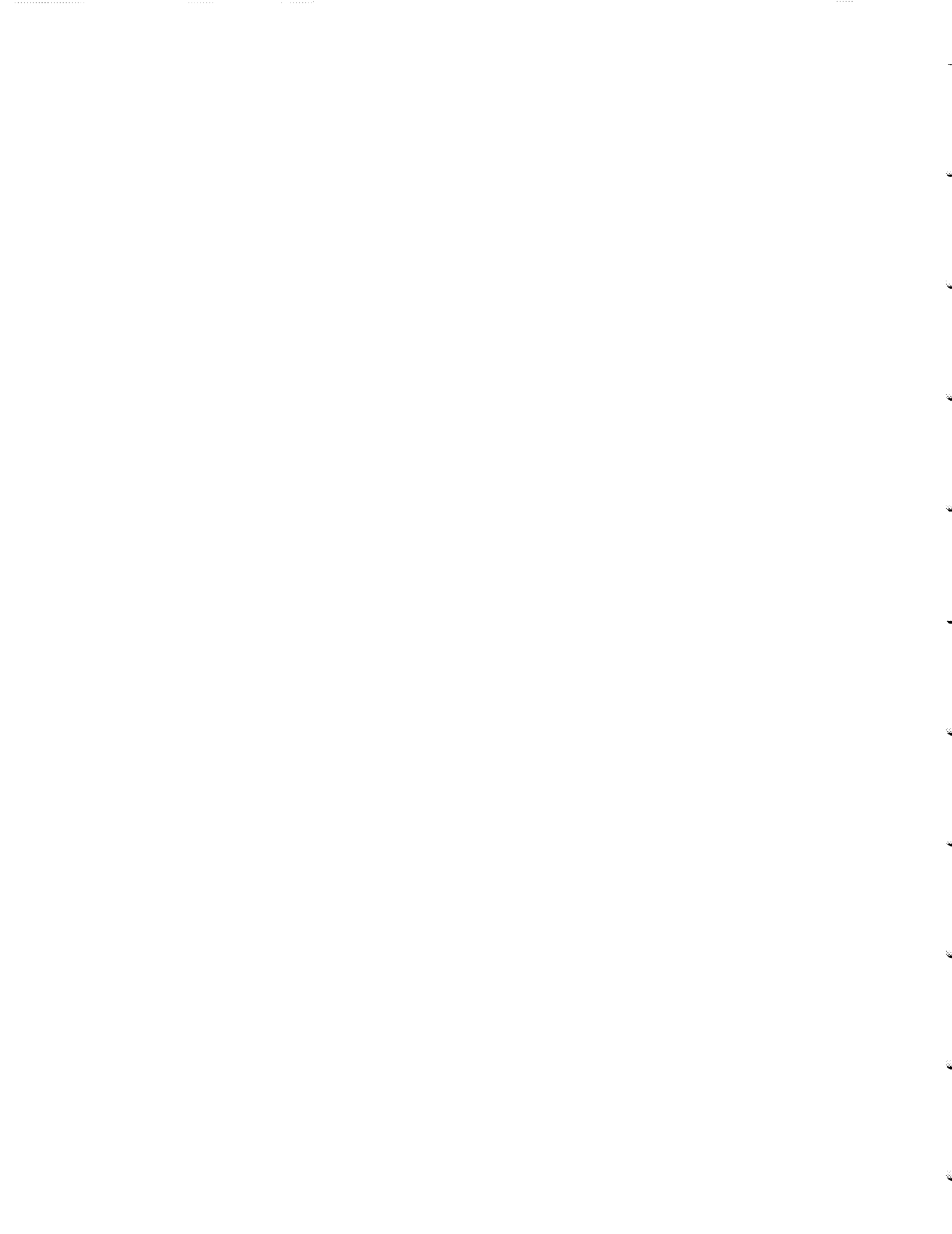

2-7. **LINE FREQUENCY REQUIREMENTS.** The counter operates at line frequencies between 48 Hz and 66 Hz.

2-8. **THREE CONDUCTOR POWER CABLE.** To protect the operator, the counter uses a grounded three-conductor detachable power cable. The male connector end is a NEMA type connector, and the female connector end is a C.E.E. type connector that mates with the 5345A rear panel power connector. Connect the power cable to a power source receptacle with a NEMA grounded third conductor. If the line power receptacle is a standard two-pin type instead of the NEMA three-pin receptacle, use a two-to-three pin adaptor (HP Part No. 1251-0048) and connect the green pigtail on the adaptor to ground.

## 2-9. REPACKING FOR SHIPMENT

2-10. If it becomes necessary to reship the counter, good commercial packing should be used. Contract packaging companies in many cities can provide dependable custom packaging on short notice. Instruments should be packed securely in a strong corrugated container (350 lb/sq. in bursting test) with suitable filler pads between the instrument and container. *The 4-corner support is not adequate, counter must also have center support.* Before returning instruments to Hewlett-Packard, contact the nearest Hewlett-Packard Sales and Service Office for instructions.

## 2-11. ENVIRONMENT DURING STORAGE AND SHIPMENT

2-12. Conditions during storage and shipment should normally be limited as follows:

- a. Maximum altitude: 25,000 feet
- b. Minimum temperature:  $-40^{\circ}\text{F}$  ( $-40^{\circ}\text{C}$ ).
- c. Maximum temperature:  $+167^{\circ}\text{F}$  ( $+75^{\circ}\text{C}$ ).

## 2-13. REMOTE PROGRAMMING AND DIGITAL OUTPUT (OPTIONS 010 AND 011)

2-14. Option 011 adds remote programming and digital output capability to the 5345A Electronic Counter. Option 010 provides digital output capability only; no provision is made to program the front panel control functions. The following paragraphs apply to Option 011 and to Option 010 except for the remote programming codes, listen function and as specified. Programming is accomplished with a bi-directional bus, via a 24-pin connector on the rear panel. Associated with this connector are five slide switches used to address the instrument. A 5345A can be addressed to send output data (TALK) (Options 010 and 011) or to accept program information (LISTEN) (Option 011 only). Several HP-IB terms are defined as follows:

- a. A TALKER sends information to the bus.
- b. A LISTENER receives information from the bus.
- c. A CONTROLLER is an instrument that has the responsibility of managing the instruments connected to the bus. It is capable of addressing other instruments on the bus as TALKERS or as LISTENERS. It is a TALKER and may be a LISTENER.
- d. "High" or "0" level of a line or switch is the relatively more positive signal level ( $>2.4\text{ V}$ ).
- e. "Low" or "1" level of a line or switch is the relatively less positive signal level ( $<0.4\text{ V}$ ).

## 2-15. Bus Description

2-16. The 15-line bus consists of 8 data lines, 3 transfer lines, plus 4 control and status lines. Addresses, program and output information are communicated on the *data* lines. These are based on a character-serial, seven-bit ASCII code set.

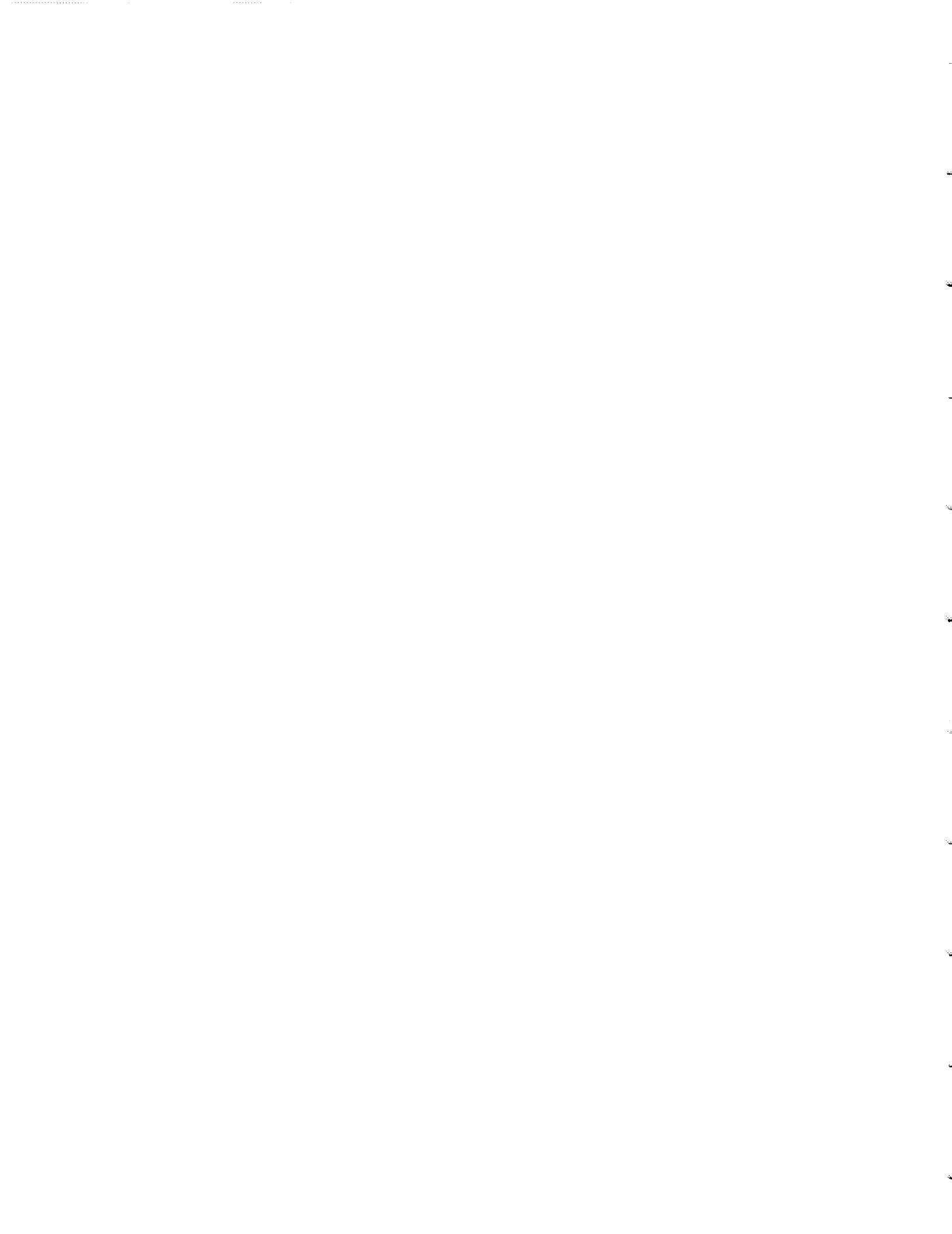



2-17. The 15 HP Interface Bus lines can be categorized into three groups by the job they perform.

a. **Data lines:** DIO1 through DIO8

Data lines (DIO1-DIO8) are used for transferring data from one instrument to another on the bus. They accommodate the 7 bits of the widely used ASCII code, leaving one bit that is not used. This line is permanently terminated in the 5345A.

b. **Transfer lines:** DAV = Data Valid. NDAC = Not Data Accepted. NRFD = Not Ready for Data.

Transfer lines DAV, NDAC, and NRFD must interact in the proper time sequence before complete communication between instruments is established. During the "three-wire transfer" a byte of data is transferred on the DIO lines.

c. **Control and Status lines:** ATN = Attention. REN = Remote Enable. IFC = Interface Clear. SRQ = Service Request.

Control and Status lines ATN, REN, and IFC are used by the controller to supervise and control the bus. Instruments on the bus use SRQ (Service Request) to inform the controller they have completed a measurement and are ready to output data.

2-18. Several 5345A's can be connected to a common bus. The exact number depends on the drive capability of the controller (see LINE CHARACTERISTICS). A specific 5345A is made to send output data (TALK) or accept program data (LISTEN) by addressing it to do so. Option 010 can be addressed to talk only.

2-19. All bus lines have been given names and mnemonic acronyms that convey the message being carried on that line. Each line is described below, followed by a table listing the relationship of the Attention and the three transfer lines. Also a figure is included showing the signal levels and timing relationship of the transfer and data lines. *ALL INSTRUMENTS CONNECTED TO THE BUS, INCLUDING THE CONTROLLER, MUST OBEY THESE DESCRIPTIONS.*

a. **SERVICE REQUEST (SRQ)**

For Option 011, when SRQ is set low the 5345A indicates to the controller that it has completed a measurement and is ready to output. It drives SRQ only if the 5345A output mode is programmed to "wait until address." When programmed in the other output mode "output ONLY IF addressed," the 5345A sets SRQ high at all times. When SRQ is high, service is not being requested. Option 010 has SRQ set high permanently.

Option 012 only. When enabled to Serial Poll, the 5345A will handshake out one status word. This word will be ASCII @ if the 5345A has enabled service request (SRQ) and will be an ASCII (NUL) if it has not enabled SRQ. This is the standard format for serial polling when SRQ is polled. The condition for removing SRQ is to:

1. Serial Poll.
2. Address the 5345A to Output.

For Option 011 and 012, if two or more 5345A's are connected to the bus and one of them sets SRQ low, the controller must go through a process of elimination to determine which one has requested service. It does this by sequentially addressing each one to TALK. Only the 5345A with output information will respond.

b. **SERIAL POLLING**

The 5345A responds to the universal commands Serial Poll Enable (SPE) and Serial Poll Disable (SPD). To serial poll the 5345A:

1. Send the Serial Poll Enable universal command ASCII (CAN).
2. Send the 5345A talk address that corresponds to the address switch setting."

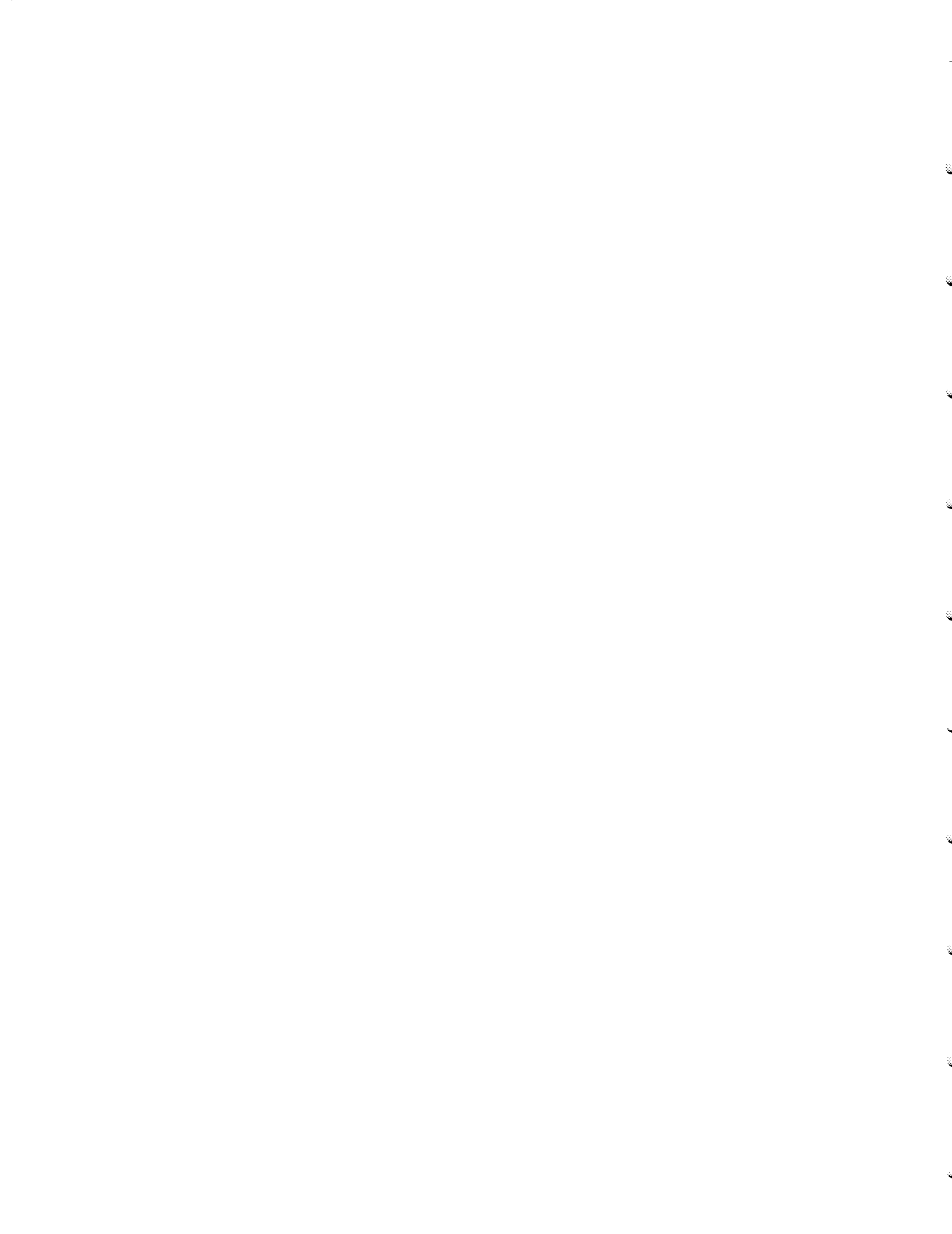

c. REMOTE ENABLE (REN) (OPTION 011 ONLY)

REN can be used by a controller to select remote or local (front panel) control of the operation of a 5345A. It works in conjunction with the information stored in the local-remote program storage cell (see paragraph 2-48 and Table 2-3). When REN is low and the 5345A has been sent an ASCII "E8" it will operate according to the information previously stored in its remote-local program storage cells. It operates according to its front panel controls for all other combinations of these, i.e., REN is low and the remote-local storage cell contains an ASCII "E0" or when REN is high regardless of what is stored in the remote-local cell. ASCII "E0" is stored in the local-remote program storage cell when either the power is turned on or the RESET pushbutton is depressed.

d. INTERFACE CLEAR (IFC)

A controller uses IFC to clear the bus. When it sets IFC low, all 5345A's immediately stop driving the data lines (DIO1 through DIO7) and transfer lines (NRFD, NDAC, and DAV). IFC will not clear a 5345A's service request (SRQ). A controller may drive IFC low at any time. When IFC is high, it has no effect on the bus operation. The 5345A monitors IFC at all times.

e. ATTENTION (ATN)

ATN is used by a controller to address a 5345A. The 5345A monitors ATN at all times. When ATN is low, all 5345A's connected to the bus interpret the information on the data lines as an address.

When ATN is high, a 5345A that has been addressed to TALK will drive the data lines. Those that have been addressed to LISTEN will interpret the information on the data lines as data. Those that have not been addressed will not drive the data lines.

f. DATA LINES (EIGHT BITS DIO1, DIO2...DIO8)

DIO1 through DIO7 carry data between the 5345A and its controller. The 5345A drives these lines when it has been addressed to TALK. The 5345A receives information on the data lines when ATN is low and it has been addressed to LISTEN. DIO8 is permanently terminated in the 5345A.

When a DIO line is high, the data bit is a logic zero (0).

When a DIO line is low, the data bit is a logic one (1).

g. NOT READY FOR DATA (NRFD)

NRFD is the transfer line that indicates listeners are ready to accept information on the data lines. Its relationship to the other transfer lines and ATN is shown in Figure 2-1 and Table 2-1.

NRFD is driven by all listeners when ATN is low and those instruments addressed to listen when ATN is high. NRFD is sensed by talkers: the controller (talker) when ATN is low, and the instrument addressed to talk when ATN is high.

When NRFD is high, all listeners are unconditionally ready for data. The talker may then, at its own time, put a byte of information on the data lines and set DAV low. When NRFD is low, one or more listeners are not ready to data.

When the controller sets ATN low, all 5345A's will set NRFD high within 200 ns. When the controller sets ATN high, all 5345A's that have not been addressed to listen will not drive NRFD.

The listener must not set NRFD low until it senses DAV is low. It may do so before or at the same time that it sets NDAC high. It must not return NRFD high until it senses DAV is high and may do so before, or at the same time that it sets NDAC low.

h. NOT DATA ACCEPTED (NDAC)

NDAC is the transfer line that indicates the acceptance of information on the data lines. Its relationship to the other transfer lines and ATN is shown in Figure 2-1 and Table 2-1. NDAC is driven by all listeners when ATN is low and those instruments addressed to listen when ATN is high. It is sensed by talkers: the controller when ATN is low and the instrument addressed to talk when ATN is high.

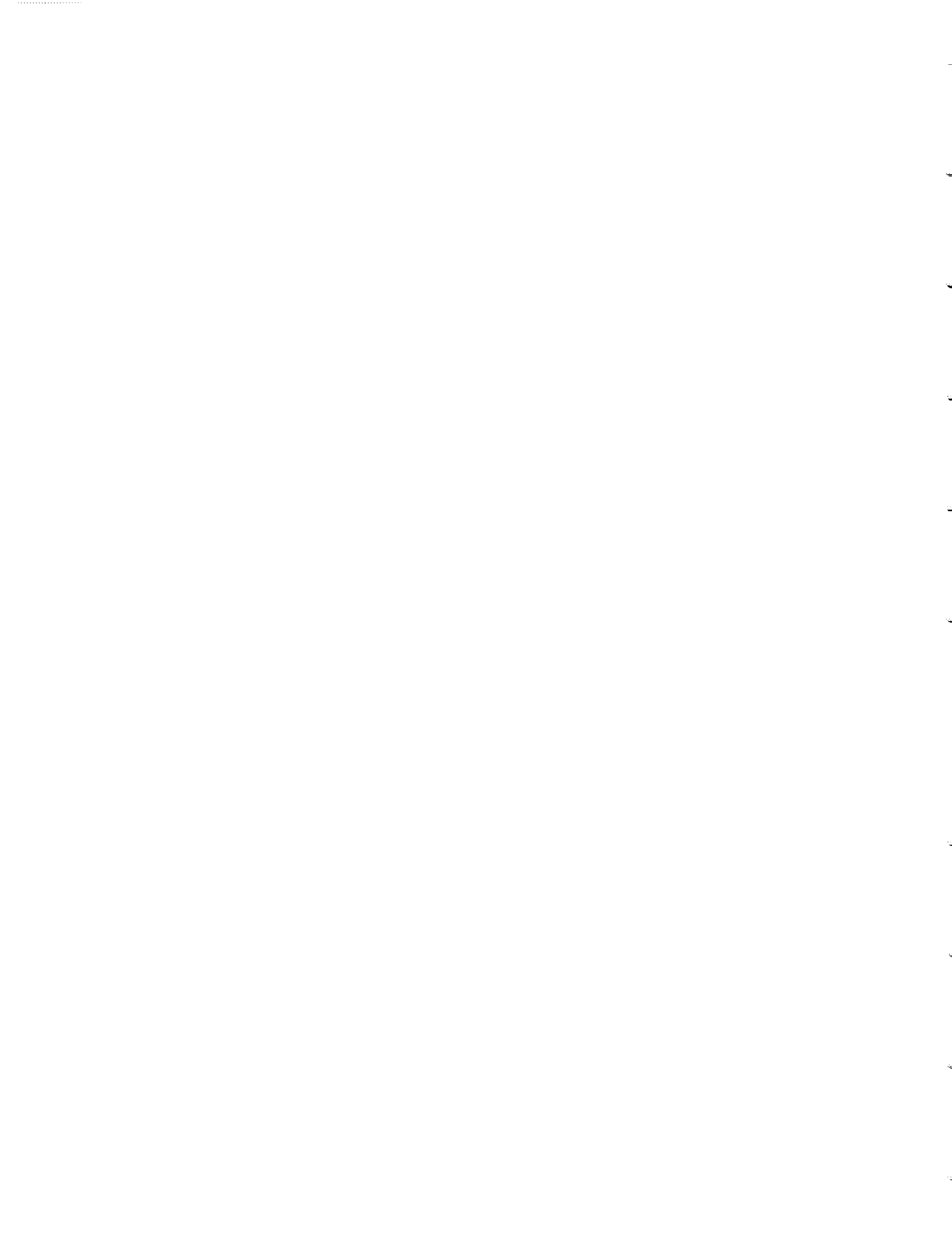

When NDAC is high, all listeners have unconditionally accepted the byte of information on the data lines and no longer need it. The talker may then, at its own time, set DAV high, remove that byte of information and continue. When NDAC is low, one or more listeners have not accepted the information on the data lines.

i. DATA VALID (DAV)

DAV, a transfer line, indicates that an ASCII character already is placed on the data lines. Its relationship to the other transfer lines and ATN is shown in Figure 2-1 and Table 2-1.

It is driven by talkers: the controller when ATN is low and by the instrument addressed to talk when ATN is high. It is sensed by listeners: all 5345A's if ATN is low and by the instruments addressed to listen when ATN is high.

When DAV is low, the states of data lines DIO1 through DIO7 are unconditionally valid and may be accepted by all listeners at their own time. DAV can be driven low only if NRFD and IFC are high. When DAV is high, the information on the data lines is not valid. DAV cannot be set high unless NDAC is high and NRFD is low.

Table 2-1. Relation of ATN and the Transfer Lines (NRFD, NDAC, DAV)

		NRFD		NDAC		DAV	
		LOW	HIGH	LOW	HIGH	LOW	HIGH
STATE OF ATTENTION (ATN) LINE	ADDRESS MODE LOW	One or more 5345A's not ready for data	All 5345A's are ready for data	One or more 5345A's has not accepted the data	All 5345A's have accepted the data	Controller has valid data on lines	Controller's data not valid
		(1) Driven by all 5345A's (2) Sensed by controller				(1) Driven by controller (2) Sensed by 5345A's	
	DATA MODE HIGH	One or more listeners are not ready for data	All addressed listeners are ready for data	One or more listeners have not accepted data	All addressed listeners have accepted the data	The addressed talker has valid data on lines	The addressed talker's data not valid
		(1) Driven by ALL instruments addressed to LISTEN (2) Sensed by the instrument addressed to TALK (3) All instruments not addressed will not drive				(1) Driven by the instruments addressed to TALK (2) Sensed by ALL instruments addressed to LISTEN	



SEQUENTIAL REQUIREMENTS OF THE THREE WIRE TRANSFER

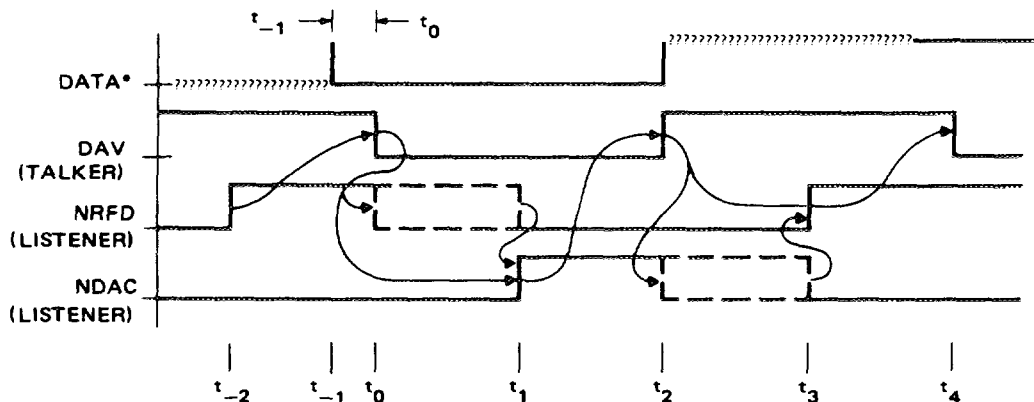

EVENTS

- $t_{-2}$  : Listener becomes ready to accept data.
- $t_{-1}$  : Talker has put data on the lines.
- $t_0$  : Indicates data is valid.
- $t_1$  : Listener has accepted the data and no longer requires it held valid.
- $t_2$  : Talker indicates the data is no longer valid and may change it.
- $t_3$  : Listener indicates it is ready for new data.
- $t_4$  : A new cycle begins (equivalent to  $t_0$ ).
- $t_{-1}$  to  $t_0$  : Time that data is put on lines before DAV is set low.

\*A composite of the DIO1 through DIO7 lines for illustrative purposes.  
 (The curved lines indicate interlocked signal sequence.)

Figure 2-1. Transfer Timing

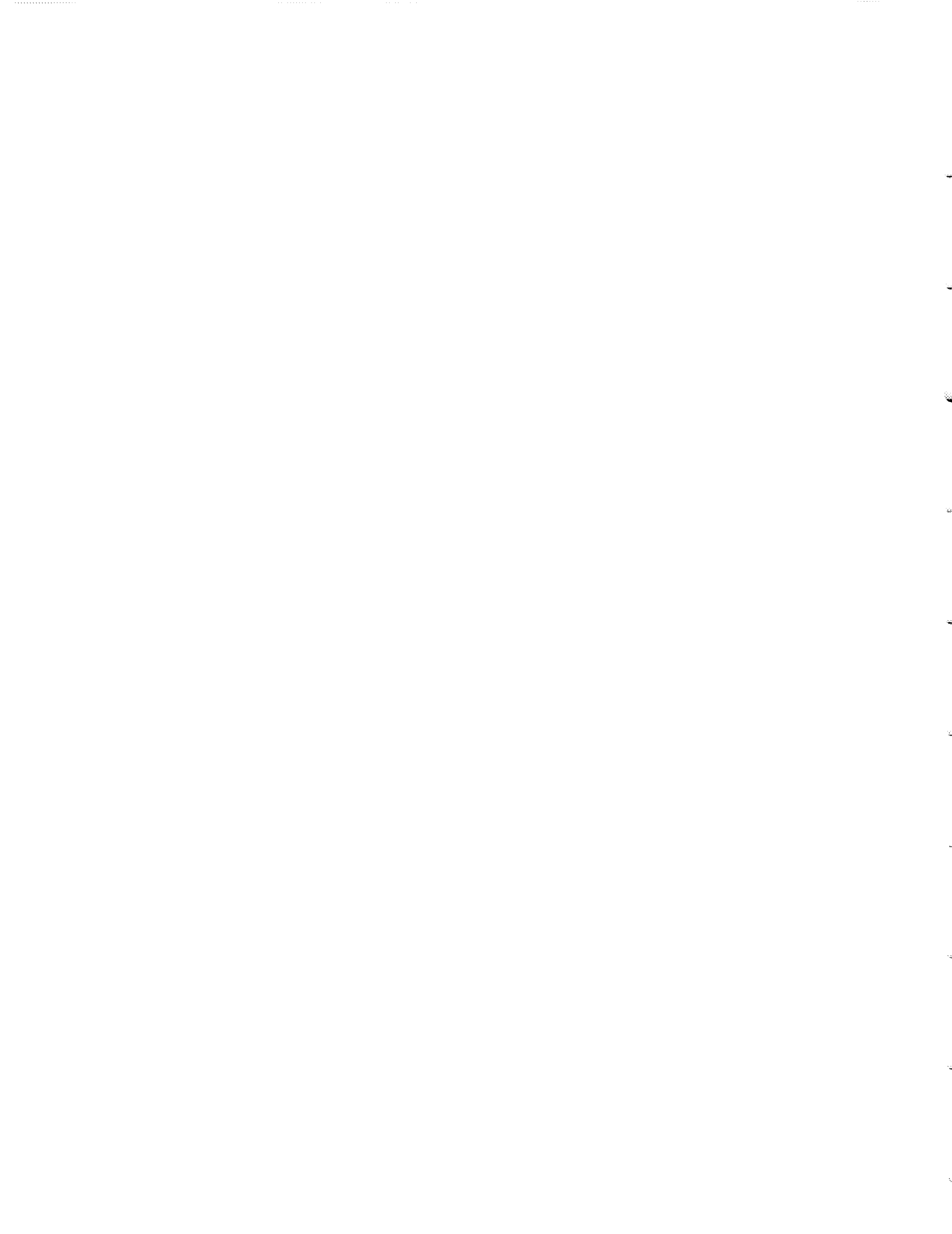



## 2-20. Data Transfer

2-21. Transfer of data on the bus is asynchronous. It places no restrictions on the data rates of instruments connected to the bus. The timing and levels required to transfer a byte of information on the data lines are shown in Figure 2-1. Transfer is under the control of three transfer lines DAV, NRFD, and NDAC. The talker (sender of data) drives DAV (Data Valid), and the listener (acceptor of data) drives both NRFD and NDAC.

2-22. The transfer of a byte is initiated by the listener, signifying it is ready for data by setting NRFD high. When the talker recognizes NRFD is high and has placed valid data on the data lines, it sets DAV low. When the listener senses that DAV is low and is finished using the data, it sets NDAC high. Since all instruments on the bus have their corresponding lines connected together (e.g., NRFD), all listeners must be in a high state before that lines goes high. This wire-AND situation allows a talker to recognize when the slowest listener has accepted a byte of data and is ready for the next byte.

## 2-23. What Can Be Programmed

2-24. For Option 011, all front and rear panel switch functions, except those on the input amplifier, are programmable. In addition, a controller can command the 5345A to make a measurement by sending a "Take a Measurement" instruction. The controller can elect to give control to the front panel controls (LOCAL) or have the 5345A operate according to the information stored in its remote program storage cells (REMOTE). These are listed in Table 2-3 along with their associated codes. Option 010 has no provision to remotely program the front panel functions.

## 2-25. Output Format

2-26. When addressed to output, the 5345A sends a space or minus, up to 11 digits of data, decimal point, the multiplier to make the reading (mHz, Hz, kHz, MHz, GHz, or ksec, sec, msec,  $\mu$ sec, nsec, and carriage return linefeed. These alpha-numeric characters are coded per the USA Standard code for Information Interchange (ASCII). When programming manual display all factitious (filler) digits are output as zeros (see paragraph 3-57).

## 2-27. Addressing the 5345A

2-28. Before a 5345A can send output data or accept program information it *MUST* be addressed to TALK or LISTEN. The method used to address it depends on the rear panel switch marked TALK ONLY — ADDRESSABLE (see Figure 2-2). When in the TALK ONLY position, the 5345A is addressed to TALK - it outputs ONLY. It operates according to the front panel controls and outputs each measurement. This position is intended for operation where there is no controller, e.g., with a digital recorder. When the rear panel switch is set to ADDRESSABLE, the 5345A can either be:

- a. Sent program information by a controller and the measured results are observed visually, or
- b. Both program and output information are passed on the bus, managed by a controller.

2-29. The thirty-one (31) LISTEN, sixteen (16) TALK, and fifteen (15) COMPUTER DUMP address characters and their signal levels are shown in Table 2-2. A unique character is selected for each 5345A with the four (4) slide switches on the rear panel marked ADDRESS (A5, A4, A3, A2). These switches may be set to either 0 or 1 (0 represents a high level and 1 a low level).

2-30. Two characters are reserved for the special function of clearing or removing a 5345A from the active state of an addressed talker or listener. The 5345A is cleared as a listener if it is sent an ASCII "?" while ATN is low. The 5345A is cleared as a talker if another instrument is addressed to talk or it is sent an ASCII "\_" while ATN is low. It is cleared as either a talker or listener when IFC is low.

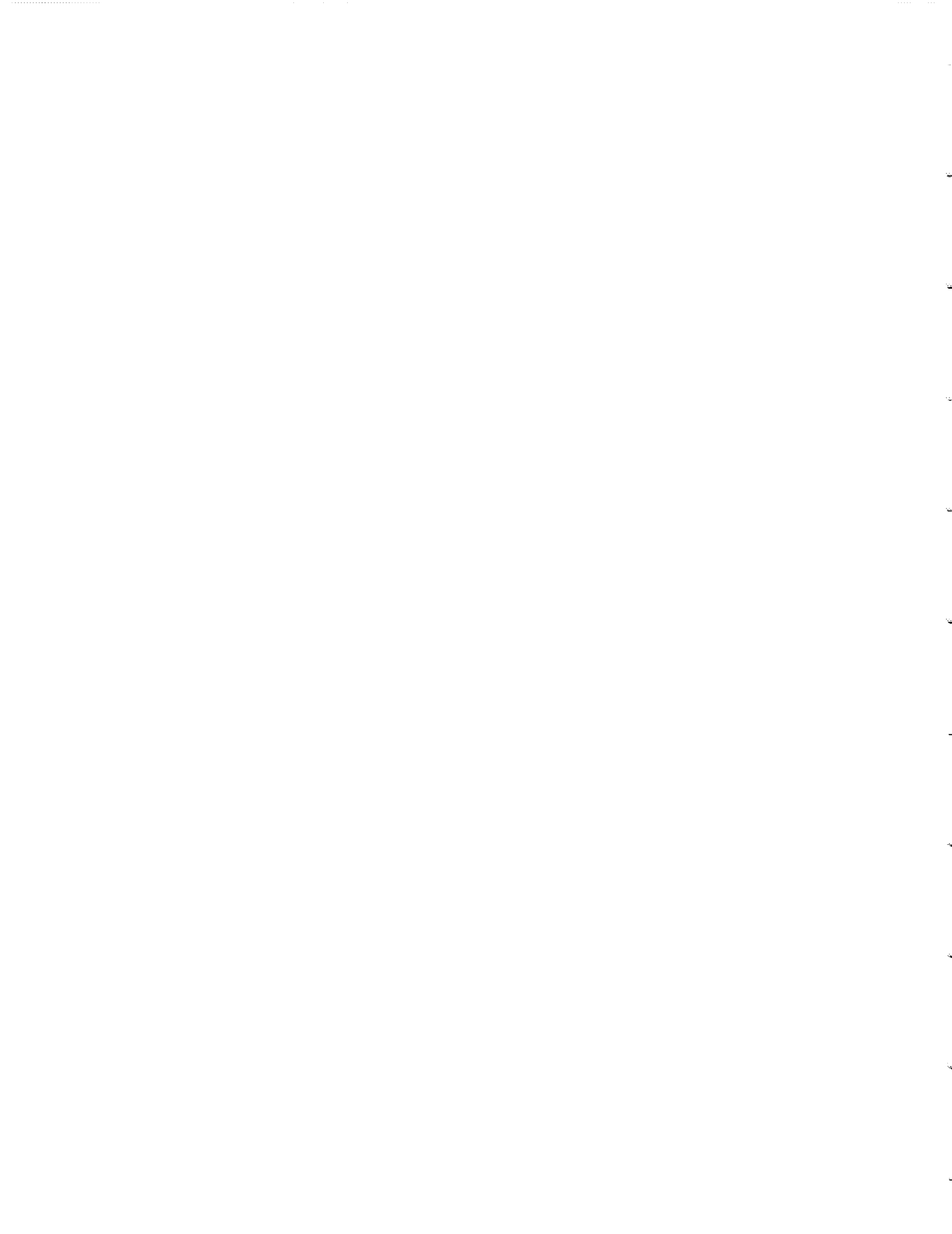

Model 5345A  
 Installation and Remote Programming

2-31. Addresses are communicated on the data lines. When the controller sets ATN low, all 5345A's interpret the information on data lines DIO1 through DIO5 as an address. During this time, the signal levels on DIO6 and DIO7 designate whether the addressed 5345A is to communicate as a talker or a listener.

D	D	D	D	D	D	D	
I	I	I	I	I	I	I	
O	O	O	O	O	O	O	
7	6	5	4	3	2	1	
1	0	A <sub>5</sub>	A <sub>4</sub>	A <sub>3</sub>	A <sub>2</sub>	0	- TALK ADDRESS*
0	1	A <sub>5</sub>	A <sub>4</sub>	A <sub>3</sub>	A <sub>2</sub>	0	- LISTEN ADDRESS*
0	0	X	X	X	X	X	- Ignored by 5345A
1	1	X	X	X	X	X	when ATN is low

A<sub>n</sub> - Address switches on rear panel

X - Don't care

\* - The clear address characters (11111) not allowed.

**NOTE**

When the 5345A is addressed from a listener to a talker or talker to a listener, the appropriate clear codes ("?" or "\_") must be issued. If underscore is not available, address a nonexistent talker.

**2-32. Computer Dump**

2-33. The 5345A has two discrete output modes. It has a talk mode and a computer dump mode. The computer dump output mode is used when it is desired to output 5345A readings (via Option 011) at extremely fast rates or to analyze raw measurement data. 5000 readings a second can be acquired in this mode. NOTE: Computer dump is not operatable with Option 010.

2-34. When the 5345A is addressed to output in this mode, it will output the contents of the denominator register and then output the numerator register contents. The processing and display cycles within the 5345A are bypassed with this mode. Computer dump is normally used when a computer is available with which to compute the measurement. The SAMPLE RATE (wait time between measurements) is <1μs in computer dump.

**2-35. Computer Dump Format**

2-36. A total of 32 ASCII digits are outputted in this mode with no CR (carriage return) or LF (line feed). Sixteen digits from the denominator register and 16 from the numerator. The counter outputs from the least to the most significant digits from the denominator followed with same order from the numerator. Contents for measurements are time for the numerator register and events for the denominator register. Count per unit time is equal to the internal clock frequency of 2 nsec.

2-37. Example: Denominator Register

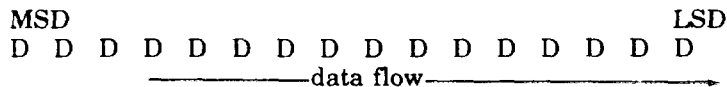

Numerator Register:

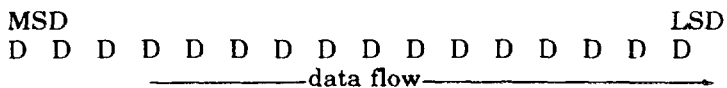

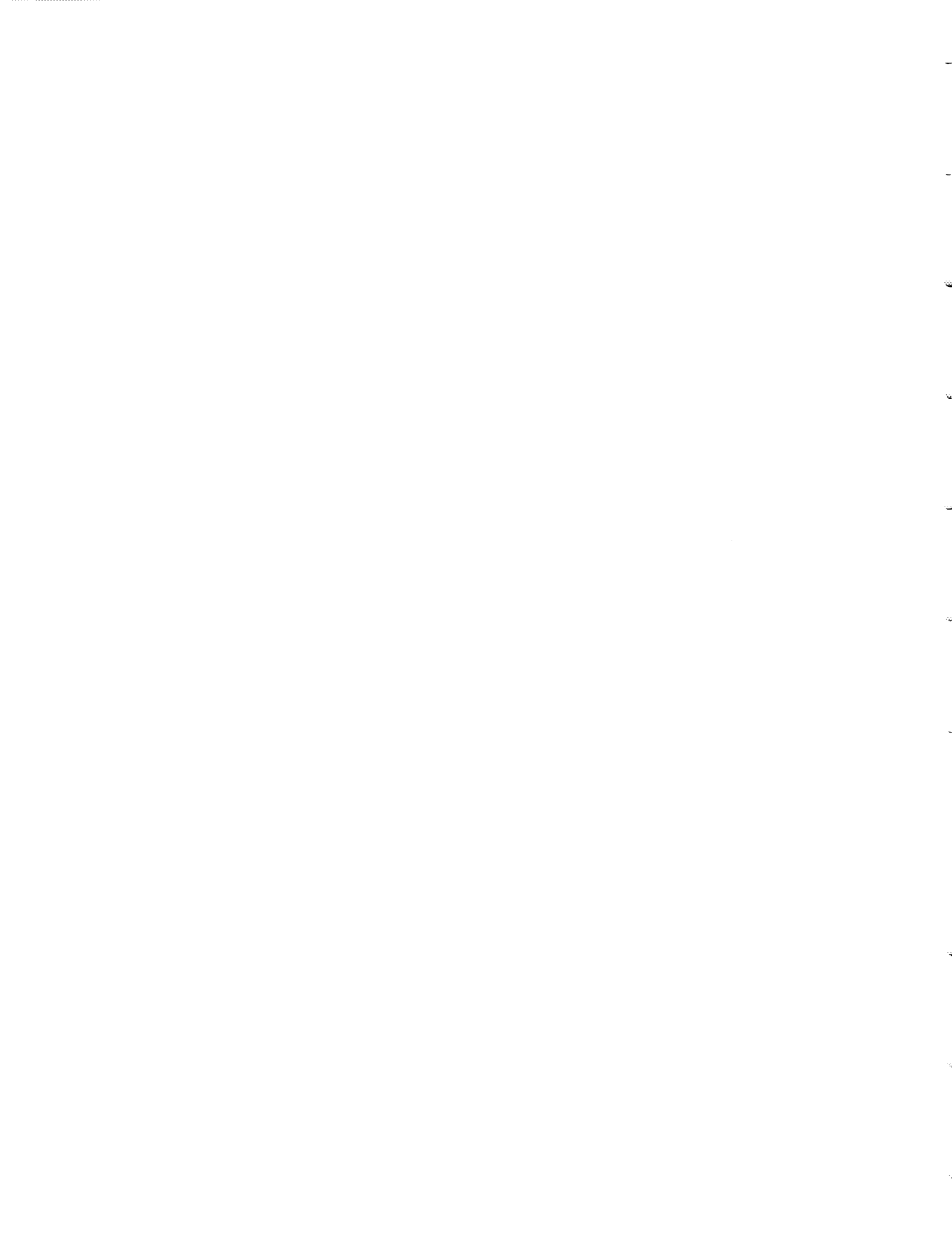

2-38. The 5345A will continue to output in this mode each time a reading is taken until such time it is unaddressed.

**2-39. Computer Dump Programming**

2-40. Table 2-2 shows all talk and computer dump codes. Note that the computer dump program code is always one-bit greater than the talk code.

**Example:**

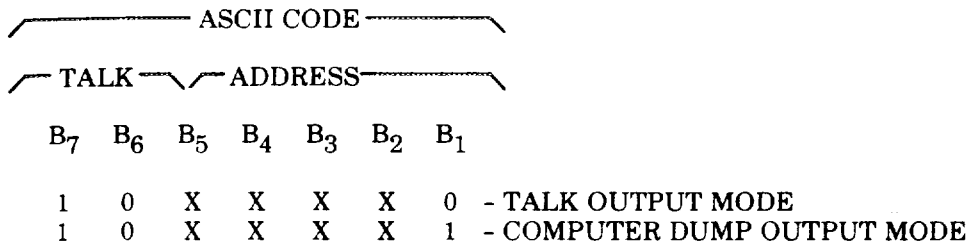

**Table 2-2. Talk and Listen Addresses**

USA STANDARD CODE FOR INFORMATION INTERCHANGE												
BITS				b <sub>7</sub> b <sub>6</sub> b <sub>5</sub>	0 0 0	0 0 1	0 1 0	0 1 1	1 0 0	1 0 1	1 1 0	1 1 1
b <sub>4</sub>	b <sub>3</sub>	b <sub>2</sub>	b <sub>1</sub>	COLUMN ROW	0	1	2	3	4	5	6	7
0	0	0	0	0	NUL	DLE	SP	0	@	P	'	p
0	0	0	1	1	SOH	DC1	!	1	A	Q	a	q
0	0	1	0	2	STX	DC2	"	2	B	R	b	r
0	0	1	1	3	ETX	DC3	#	3	C	S	c	s
0	1	0	0	4	EOT	DC4	\$	4	D	T	d	t
0	1	0	1	5	ENQ	NAK	%	5	E	U	e	u
0	1	1	0	6	ACK	SYN	&	6	F	V	f	v
0	1	1	1	7	BEL	ETB	'	7	G	W	g	w
1	0	0	0	8	BS	CAN	(	8	H	X	h	x
1	0	0	1	9	HT	EM	)	9	I	Y	i	y
1	0	1	0	10	LF	SUB	*	:	J	Z	j	z
1	0	1	1	11	VT	ESC	+	;	K	[	k	}
1	1	0	0	12	FF	FS	,	<	L	\	l	!
1	1	0	1	13	CR	GS	-	=	M	]	m	}
1	1	1	0	14	SO	RS	.	>	N	^	n	~
1	1	1	1	15	SI	US	/	?	O	_	o	DEL

LISTEN
  TALK

COMPUTER DUMP OUTPUT CODES ONLY.  
 CANNOT BE USED AS TALK OUTPUT CODES.

NOTES: ? = CLEAR LISTEN  
 — = CLEAR TALK

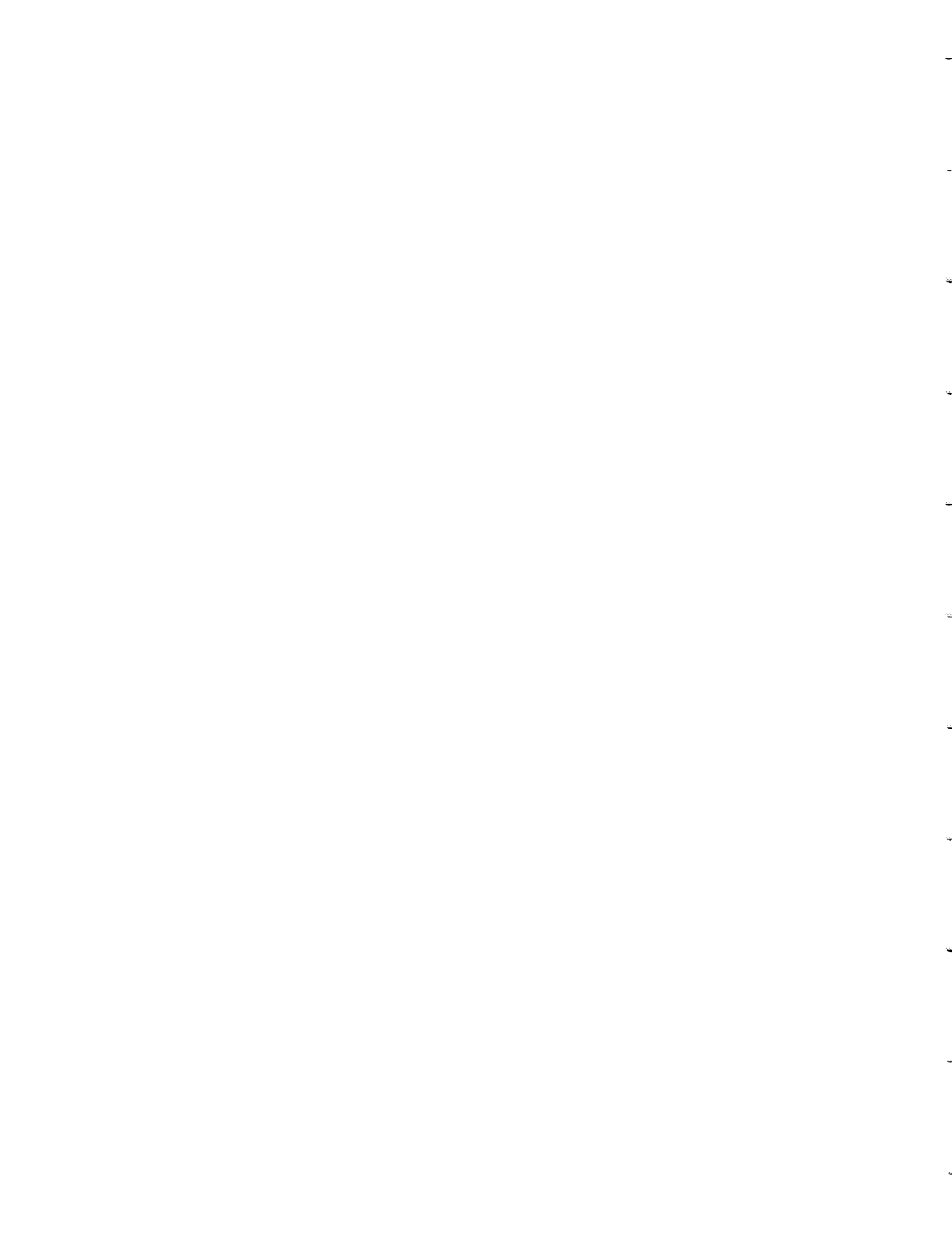

Model 5345A  
Installation and Remote Programming

**2-41. Line Characteristics**

2-42. All 15 bus lines are designed to be compatible with TTL or DTL integrated circuits. Because wire-ANDing is used on some lines, the TTL line drivers must be either open collector or tri-state. Each line in the 5345A is terminated in a resistor divider consisting of a 3K connected to 5V and a 6.2K connected to ground. All receivers are hex inverters (SN 7404N or equivalent) and the drivers are open collector NAND gates (SN 7438N or equivalent). These may be put into four groups:

- a. IFC, ATN, and REN are receivers only. They require -3.2 mA max. at 0.4V to drive.

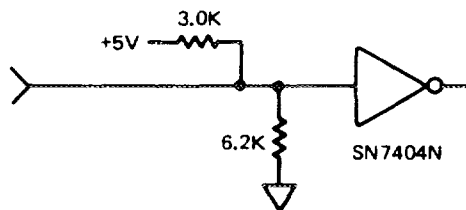

- b. SQR is output only: It is capable of sinking 45 mA at +0.4V.

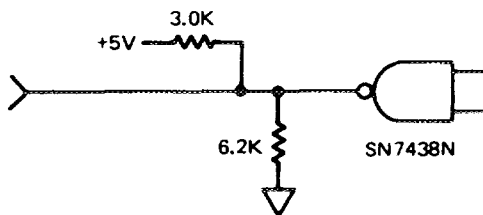

- c. Data lines (DIO1 through DIO7) and the transfer lines (NRFD, NDAC, and DAV) are bi-directional. They are a combination of a and b, i.e., when a talker, capable of sinking 45 mA at 0.4V; when a listener, requires -3.2 mA at 0.4V to drive.
- d. DIO8 is connected to a similar divider and is always at 3.2V at 2K impedance.

**2-43. Hardware**

2-44. The 5345A digital INPUT/OUTPUT connector is on the rear panel (Figure 2-2). Pin connections to this Type 57 Microribbon connector are shown in Figure 2-3.

2-45. Cables of three different lengths are available for connecting a 5345A to a controller or another 5345A:

- a. 3 feet long HP Part No. 10631A.
- b. 6 feet long HP Part No. 10631B.
- c. 12 feet long HP Part No. 10631C.

2-46. These have one overall shield to reduce susceptibility to external noise. The cables use a mixture of individual wires and twisted pairs to reduce crosstalk. Both ends are identical. They are terminated in two 24-pin piggy back connectors: one male and one female. This termination permits several cables to be connected to the same 5345A. Pin connections of these connectors are shown in Figure 2-4. There is a restriction of no more than 12-feet between the first two instruments in the system and 6-feet between the remaining instruments. The 5345A can drive a maximum of 50-feet of this cable.





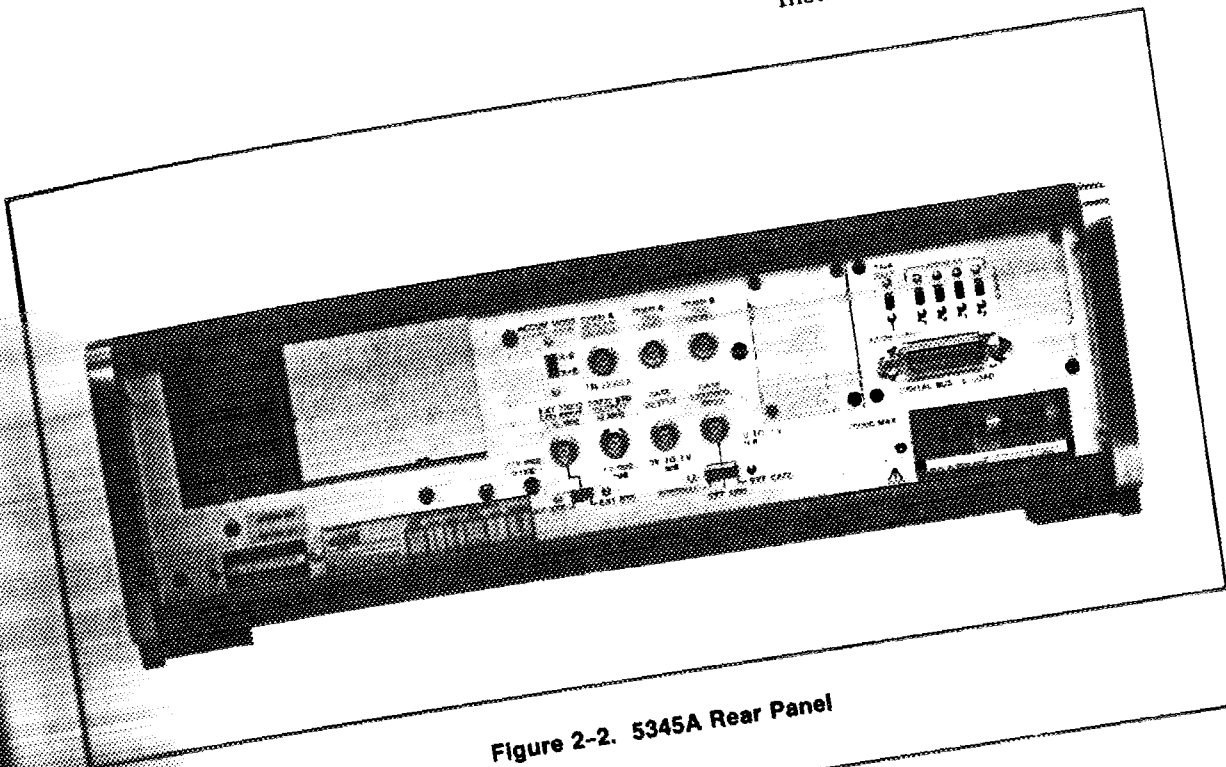

Figure 2-2. 5345A Rear Panel

are bi-  
linking

Pin con-  
troller or

cables use a  
ntical. They  
termination  
connectors  
the first two  
5A can drive

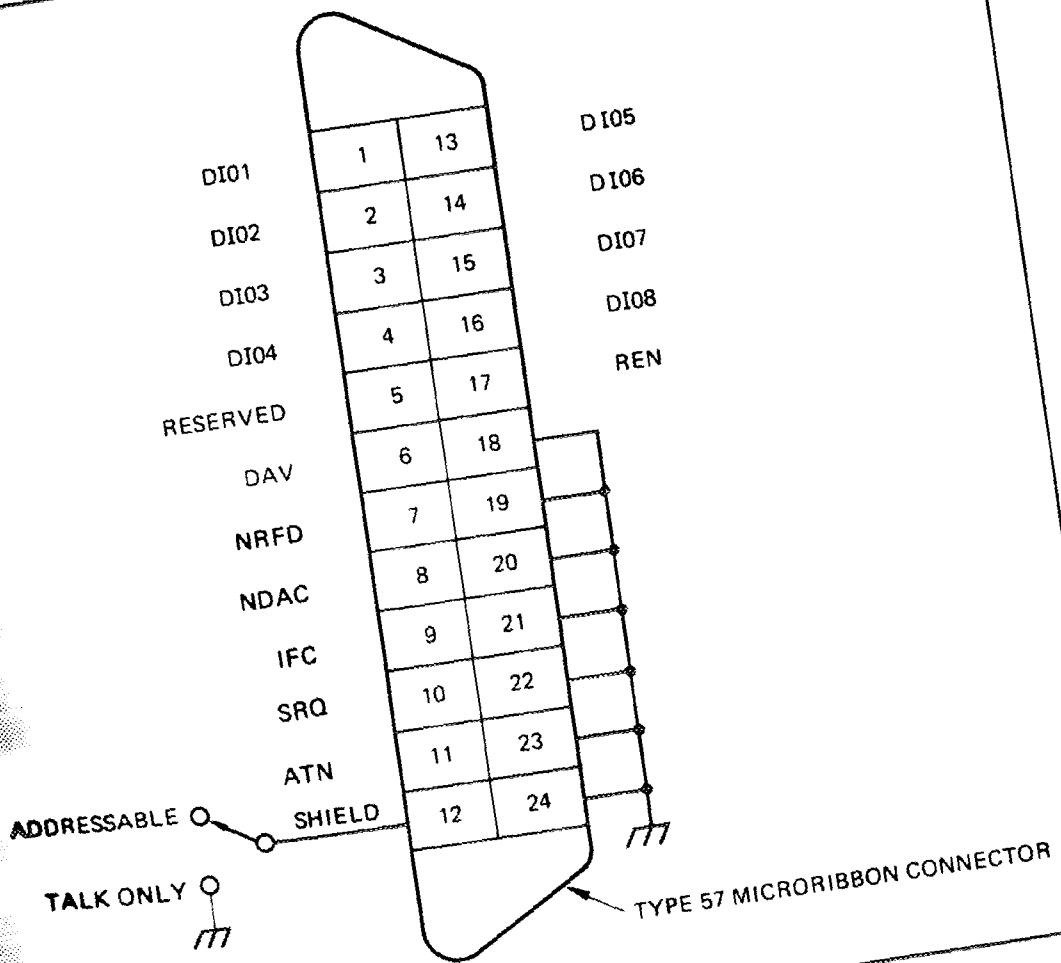
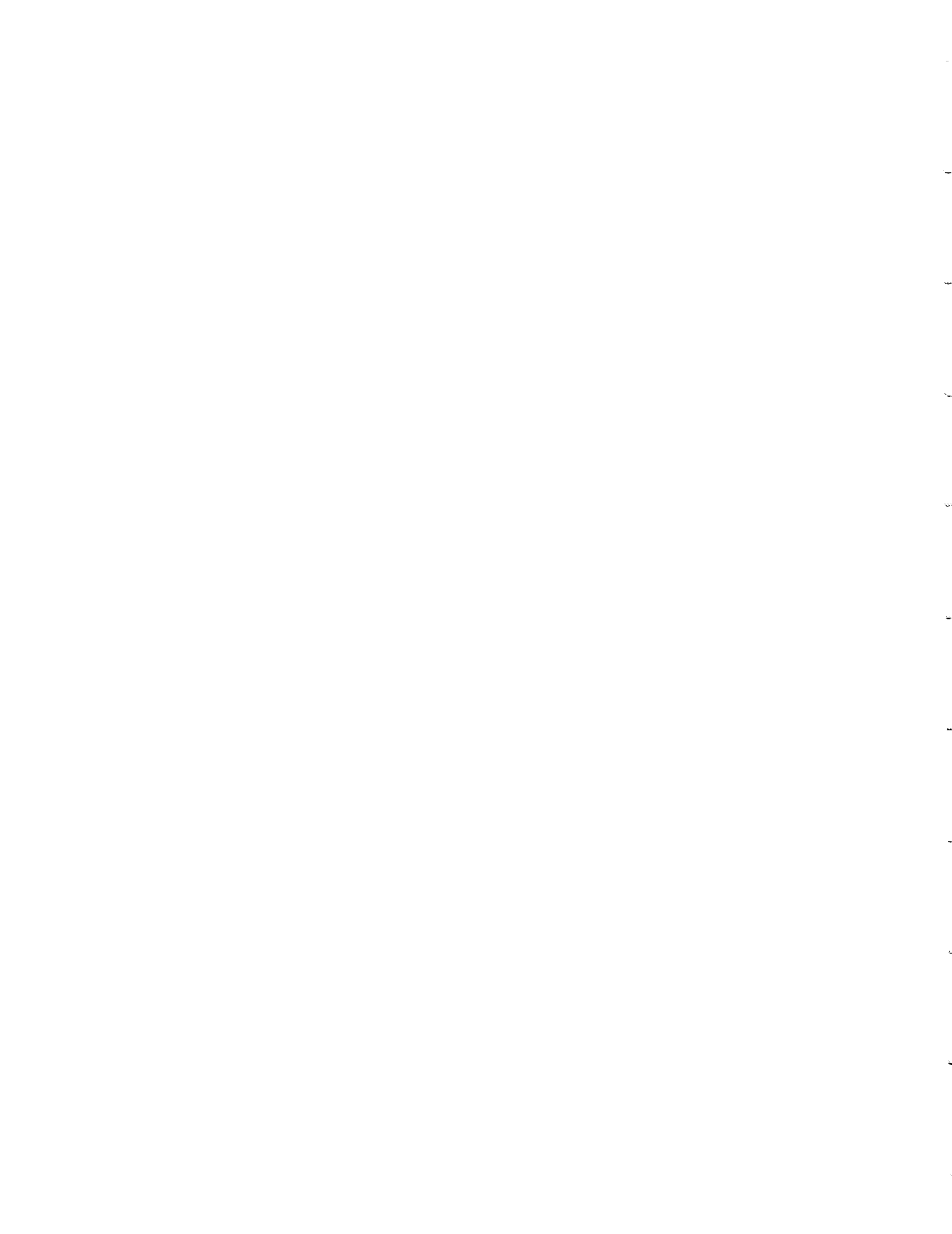
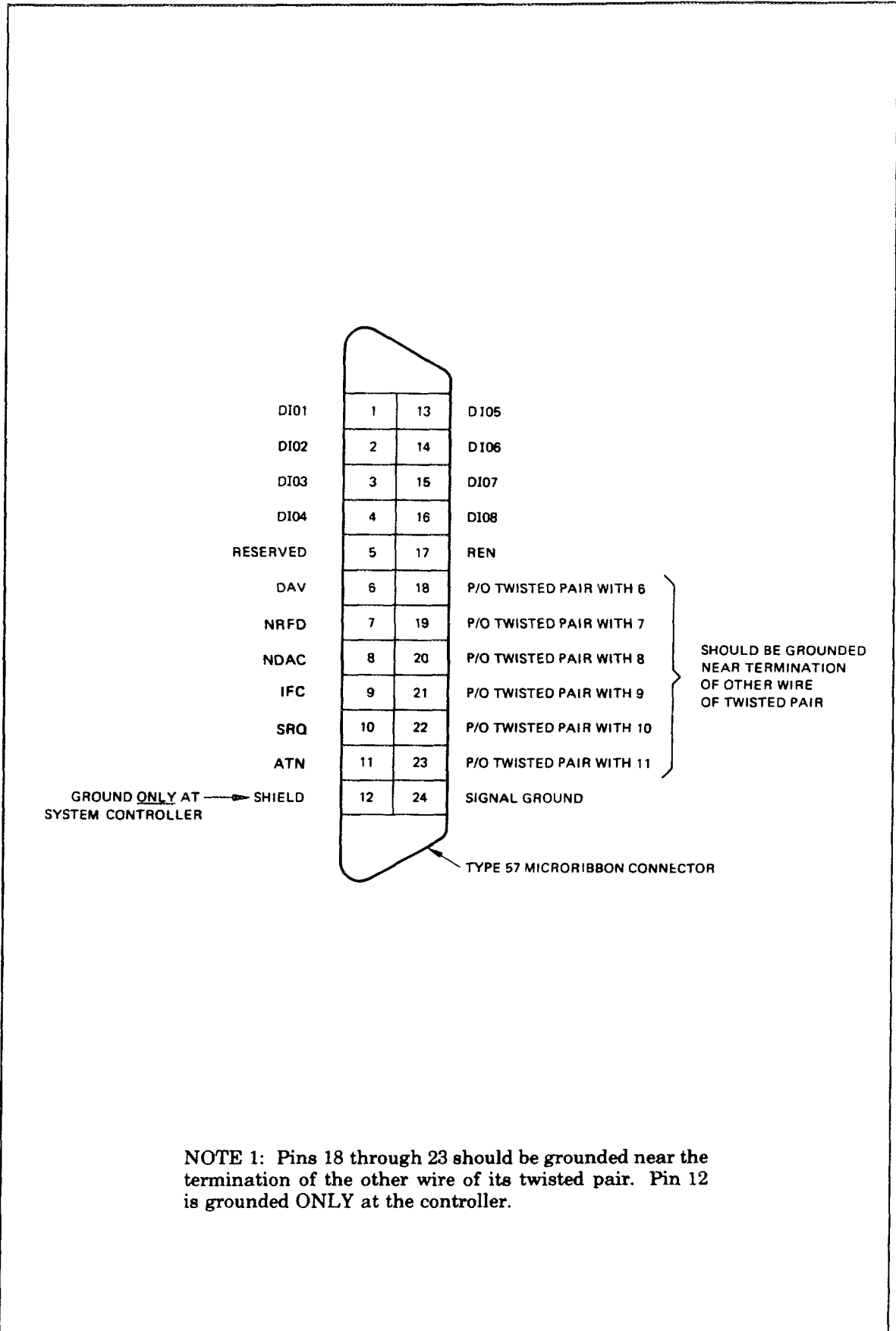

Figure 2-3. 5345A Digital Input/Output



Model 5345A  
 Installation and Remote Programming



NOTE 1: Pins 18 through 23 should be grounded near the termination of the other wire of its twisted pair. Pin 12 is grounded ONLY at the controller.

Figure 2-4. Pin Connections of the 10631A, B, C Cables

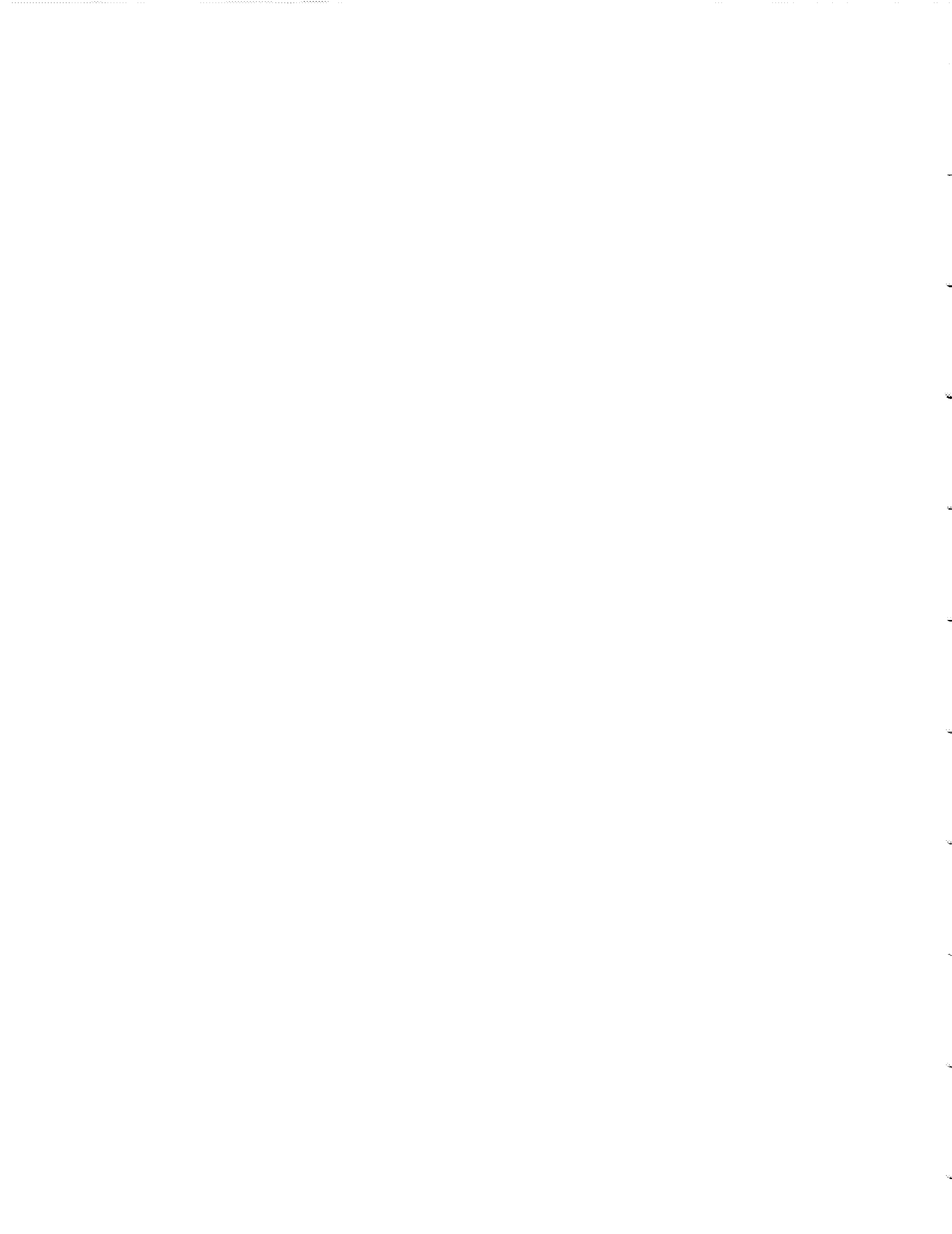

2-47. Programming the 5345A (Option 011 Only)

2-48. The 5345A has a group of storage cells that are used to store program information. They are used ONLY when a controller has the 5345A operating under remote control. The ASCII characters that can be stored in each cell and their relationship to the 5345A's operation are shown in Table 2-3. (Refer to Table 2-2 for signal levels.)

Table 2-3. Program Code Set, Option 011

1. Function	ASCII	OCTAL*	7. Output Mode	ASCII	OCTAL*		
a. Plug In .....	F2	106062	a. ONLY IF Addressed .....	E2	105062		
b. Frequency A .....	F0	106060	b. WAIT Until Addressed .....	E:	105072		
c. Period .....	F1	106061	(See NOTE following paragraph 2-50.h.2)				
d. Time Interval A to B .....	F3	106063	8. Display Position				
e. Ratio B/A .....	F5	106065	(Digits from E in Data String)				
f. Start .....	F4	106064	(Digit Position Defined from Right to Left,				
g. Stop .....	F6	106066	Decimal Point on Right Side of Digit)				
2. Accum Mode Start/Stop (If F4 or F6)			a. 0 Digits .....	D;	104073		
a. A+B .....	E=	105075	b. 1 Digit .....	D:	104072		
b. A-B .....	E5	105065	c. 2 Digits .....	D9	104071		
3. Remote Gating			d. 3 Digits .....	D8	104070		
a. External Gate .....	E;	105073	e. 4 Digits .....	D?	104077		
b. Internal Gate .....	E3	105063	f. 5 Digits .....	D>	104076		
4. Gate Time			g. 6 Digits .....	D=	104075		
a. 10000 sec .....	G4	107064	h. 7 Digits .....	D<	104074		
b. 1000 sec .....	G3	107063	i. 8 Digits .....	D3	104063		
c. 100 sec .....	G2	107062	j. 9 Digits .....	D2	104062		
d. 10 sec .....	G1	107061	k. 10 Digits .....	D1	104061		
e. 1 sec .....	G0	107060	l. Auto Position + Auto				
f. 100 ms .....	G?	107077	Suffix Multiplier .....	D0	104060		
g. 10 ms .....	G>	107076	9. Display Multiplier Suffix (If other than D0)				
h. 1 ms .....	G=	107075					
i. 100 μs .....	G<	107074	FREQ.	PERIOD/ TIME INTERVAL	START/ RATIO	ASCII	OCTAL*
j. 10 μs .....	G;	107073	GHz	nsec	G	C7	103067
k. 1 μs .....	G:	107072	MHz	μsec	M	C6	103066
l. 100 msec .....	G9	107071	kHz	msec	k	C5	103065
m. Min .....	G5	107065	Hz	sec		C4	103064
			mHz	ksec		C3	103063
Input Amplifier Control						ASCII	OCTAL*
a. COM A or Separate .....	E7	105067	10. Remote Program Initialize .....	I2		I2	111062
b. Check .....	E?	105077	11. Local — Remote				
Sample Rate Selection			a. Switch to Local .....	E0	105060		
a. Maximum Sample Rate			b. Switch to Remote .....	E8	105070		
(1-100 msec) .....	E1E4	{105061	12. Reset Command .....	I1	111061		
		{105064	(End of 100 ms reset pulse				
b. Minimum Time			initiates measurement cycle)				
(3-6 msec) .....	E1E<	{105061	13. Sample Trigger Command				
		{105074	(If E9) .....	J1	112061		
c. HOLD .....	E9	105071					

RESET PUSHBUTTON/POWER UP/I2 PROGRAM conditions are F0, G0, D0, E7, E0, E2, E3, E1, E4, E5

Settings are given to aid in troubleshooting.

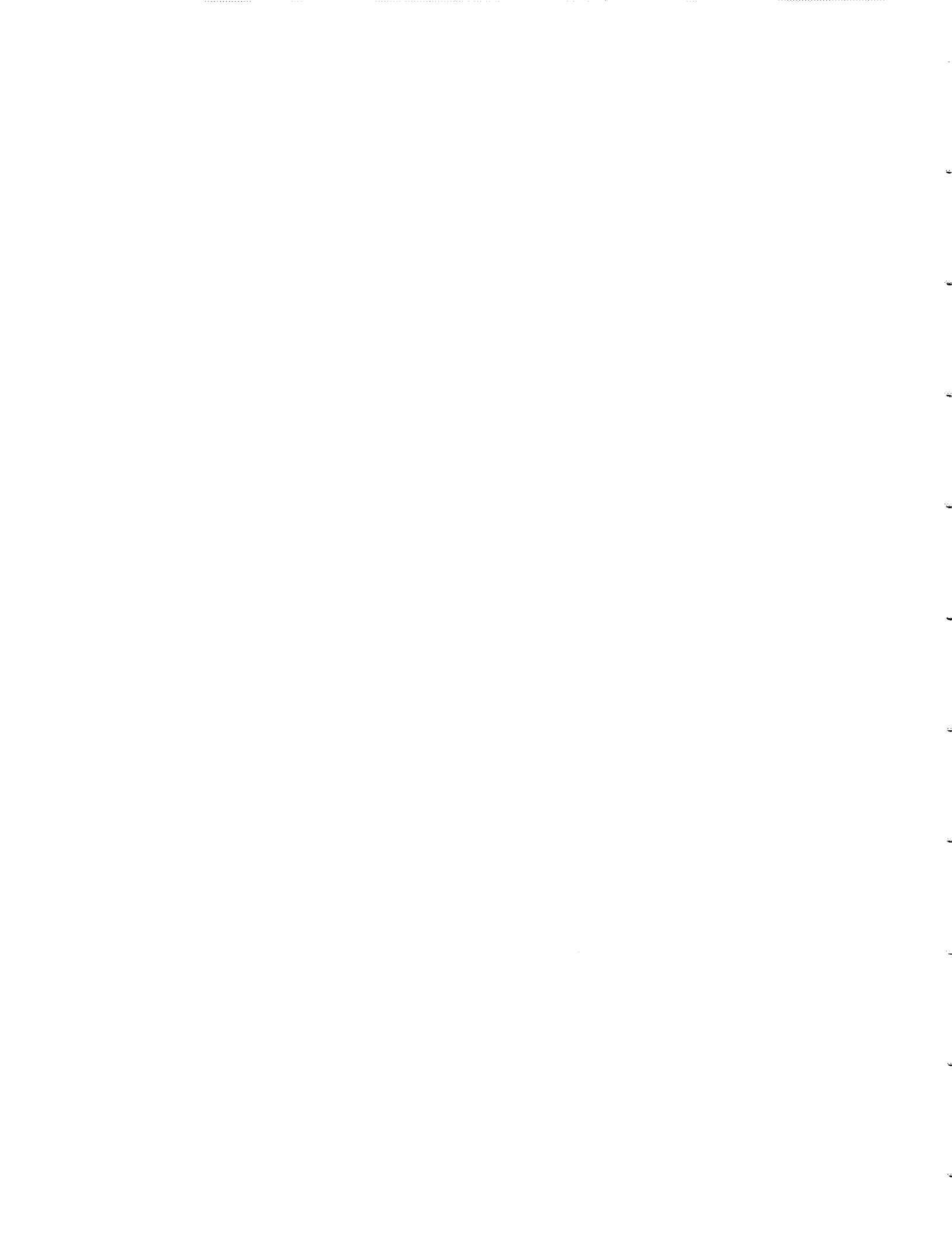

2-49. The program storage cells are loaded with a predetermined set of conditions when either the front panel RESET pushbutton is depressed, power is turned on, or the special program code (Remote Program Initialize) I2 is issued. The initial conditions are listed in Table 2-3 under RESET PUSHBUTTON/POWER UP I2. Notice that each time either the RESET pushbutton is depressed, power is turned OFF - then ON, or program code I2 is issued, the 5345A operates according to its front panel controls.

#### 2-50. Program Function Descriptions (Option 011 Only)

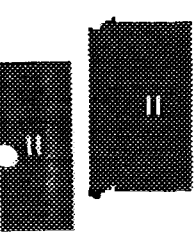
- 
- a. Function and Gate - Related directly to the front panel controls. For example, ASCII "F0" and ASCII "G0" select Frequency A function and 1 second gate time, respectively.
  - b. Display - The auto position (ASCII "D0") will normally be programmed. This positions the display's least-significant digit in the right most column with the correct Display Multiplier automatically selected. Programming the display multiplier is not required in Auto Display. Manual display programming of 0 digits to 10 digits shifts the decimal point, hence the display, one place left for each programmed code. Manual requires a multiplier suffix to be programmed.
  - c. Display Multiplier Suffix - Used only when Manual Display has been programmed. Selects the correct unit of time or frequency.
  - d. RESET (I1) - The reset command causes the current measurement cycle to be terminated and a new cycle to begin (i.e., it also acts as a sample trigger). After sending any new programming codes, I1 must terminate the code string to ensure that a measurement cycle is begun using the new codes. If I1 is given when the counter is in the WAIT until addressed mode (E:), the counter will immediately go to an output cycle and output all zeros. Only when the output is complete and sample trigger occurs will a new measurement begin. Hence, under these conditions, the first reading into the calculator (consisting of all zeros) must be discarded.
  - e. Remote Program Initialize Instruction I2 - Sets the remote program storage cells to the initial conditions of instrument power up or front panel reset. The stored program is F0, G0, D0, E7, E0, E2, E3, E1, E4, E5. They are:
    - F0 - Frequency A
    - G0 - 1 sec gate time
    - D0 - Auto display position
    - E7 - COM A or Separate (depending on front panel position)
    - E0 - Local operation
    - E2 - Output only if addressed to talk
    - E3 - Internal gate
    - E1 - Sample rate not hold
    - E4 - Sample rate  $\approx$  50 msec time
    - E5 - A-B Start mode

When taking control of the 5345A it is necessary to change only those storage cells that are different from the above. For example, if the 5345A is to be used under remote control for a period measurement at 100 msec gate time it is only necessary to change the ASCII "F0" and "G0" to ASCII "F1" and "G?", respectively.

- f. Input Amplifier Control
  1. COM A or Separate (E7) - This programs the position of the COM A and SEP Switch on the front panel. Example: If program code E7 is issued and the Input Amplifier Control switch is set to COM A position, COM A will be selected. If, however, the front panel switch was set to SEP, then Separate is selected.
  2. Check (E?) - This program selects the front panel check mode. The check mode is always selected regardless of Input Amplifier Control positions.

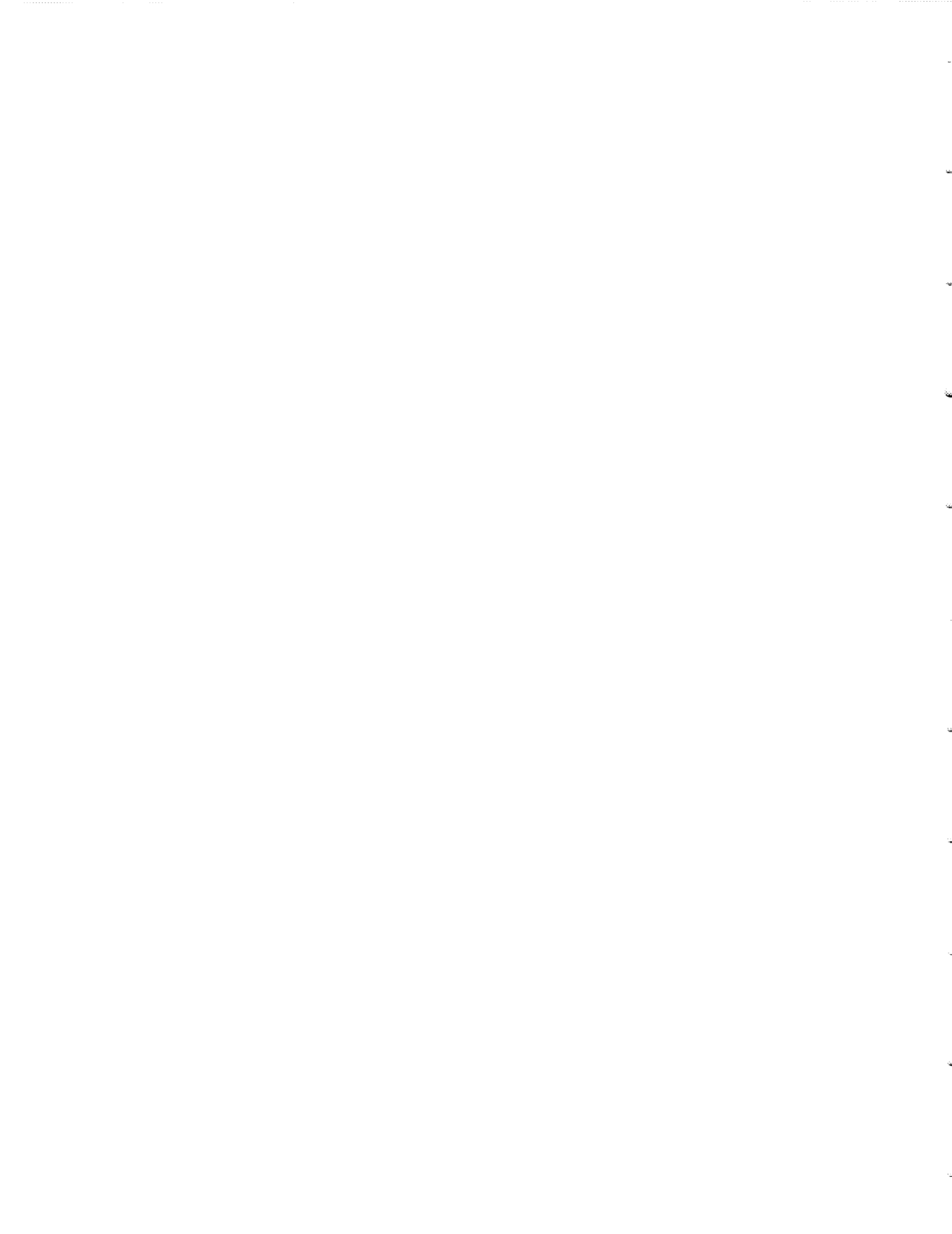



- g. Local-Remote
1. Local - The 5345A operates according to its front panel controls.
  2. Remote - Used in conjunction with the control line REN (Remote Enable) to have the 5345A operate according to the information in its program storage cells.
- h. Output Modes - A 5345A outputs in one of two modes, providing it has been addressed to TALK.
1. ONLY IF addressed (ASCII "E2" stored in the program storage cell). The 5345A will output each measurement if it has been addressed to TALK. If not so addressed, it bypasses the entire output phase of its operating cycle.
  2. WAIT until addressed (ASCII "E:" stored in the program storage cell). The 5345A will make a measurement, then wait in the output phase of its operating cycle until it is addressed to TALK. When waiting in the output phase, the 5345A display will be blank. As soon as it is so addressed, it will output and continue according to the information in its program storage cells.

**NOTE**

The output routine will be bypassed in the WAIT mode (ASCII characters E:) if the bus is in the DATA MODE with no listeners. This is a feature of the 5345A counter which prevents counter hang-up if the HP-IB cable is detached.

Notice that the 5345A ALWAYS outputs when it reaches the output phase of its operating cycle IF it has been addressed to TALK. When programmed ONLY IF, the 5345A continues to go through its operating cycle, bypassing the output phase until addressed to TALK. When programmed to WAIT, the 5345A will stop at its output phase and stay there until addressed to TALK.

- i. Remote Gating
1. External Gate ("E;"). Selects EXT GATE position of Gate Control switch for control of gate circuits.
  2. Internal ("E3"). Selects INTERNAL position of Gate Control switch, allowing normal operation of the counter.
- j. Sample Rate Selection - The programmed sample rate determines the "wait time" between measurements. This is the time from the end of processing to the time the counter is armed for the next measurement.
1. Maximum Sample Rate (E1E4). Equivalent to selecting the maximum sample rate with the front panel sample rate control. This results in a wait time of 50 to 100 msec.
  2. Minimum Time (E1E<). This results in the fastest repetitive measurement cycles possible since the sample rate portion of the measurement cycle is effectively bypassed. For normal talk mode, the wait time in this mode is <100  $\mu$ sec plus the 1 to 5 msec processing time. For the unprocessed format talk mode (computer dump), the time is <1  $\mu$ sec plus the output time of 107  $\mu$ sec into an infinitely fast receiver.

**NOTE**

In Minimum mode, the counter display will be blank. If E1 has been previously programmed, only E4 or E< must be sent.

3. HOLD (E9). The counter will wait until a Sample Trigger Command (J1) occurs and then the measurement cycle begins.

k. ACCUM MODE START/STOP - Used when totalizing two input signals:

1. A+B (E=). Counts of each channel are added for the total displayed count.
2. A-B (E5). B counts are subtracted from Channel A counts.

Program Codes and Universal Commands for Option 012

Tables 2-4 and 2-5 list the program codes and universal commands for the Remote Programming Option 012.

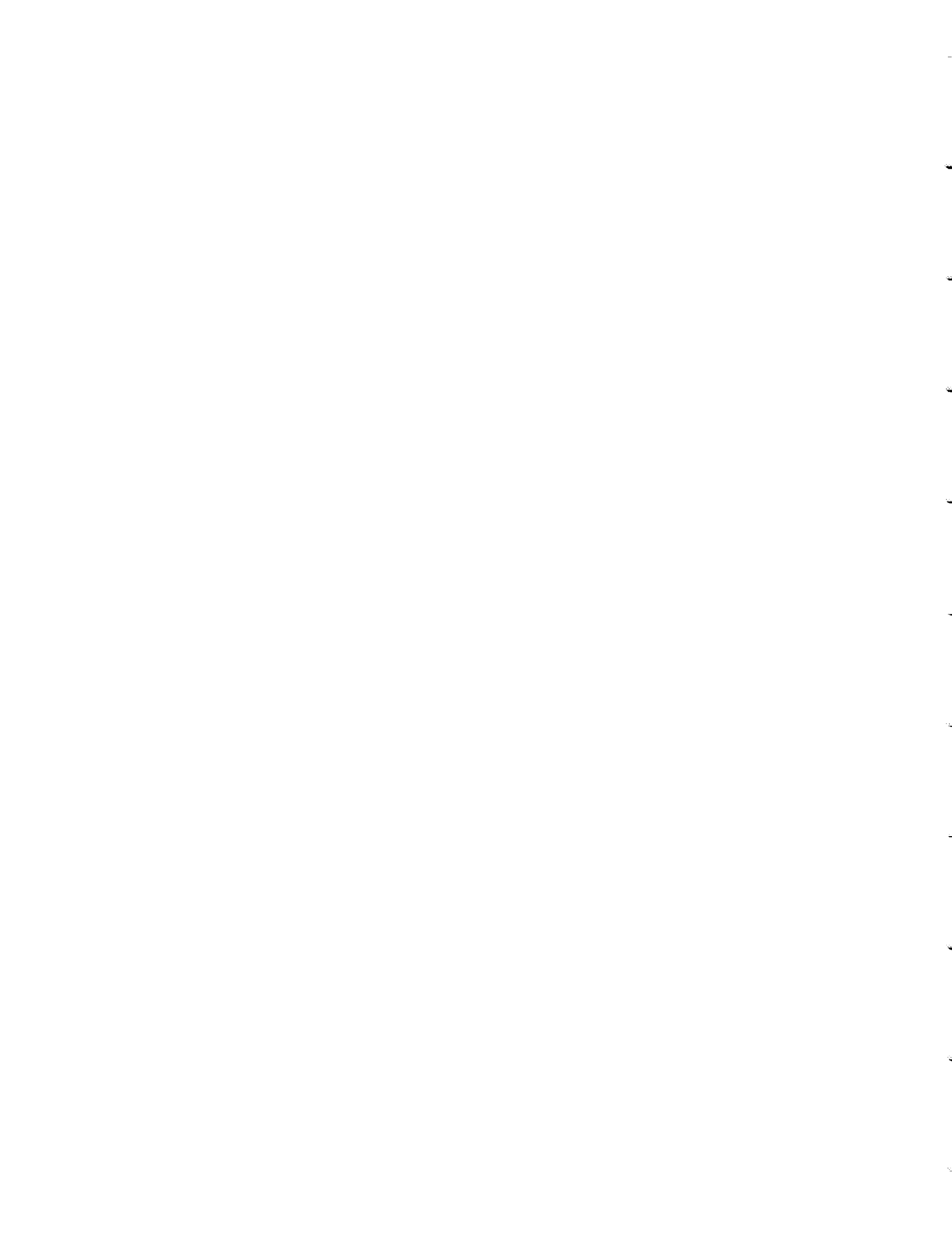

Table 2-4. Program Code Set for 5345A Option 012

<b>1. Function</b>	<b>ASCII</b>	<b>6. Local-Remote</b>		
a. Plug-In .....	F2	Selects remote upon addressing provided the bus REN is assertive.		
b. Frequency A .....	F0			
c. Period .....	F1	<b>7. Output Mode</b>		
d. Time Interval A to B .....	F3	a. Output only if addressed to Talk; bypass if addressed to Talk .....		
e. Ratio B/A .....	F5	b. Hold current measurement until addressed to Talk .....		
f. Start .....	F4			
g. Stop .....	F6			
<b>2. Gate Time</b>		<b>NOTE</b>		
a. 10000 sec .....	G4	The output routine will be bypassed in the wait mode (ASCE) if the bus is in the DATA MODE with no listeners. This is the result of a 5345A feature which prevents hang-up of the 5345A in the event the HP-IB cable is disconnected.		
b. 1000 sec .....	G3			
c. 100 sec .....	G2			
d. 10 sec .....	G1			
e. 1 sec .....	G0			
f. 100 ms .....	G?			
g. 10 ms .....	G>			
h. 1 ms .....	G=			
i. 100 μs .....	G< or G<*			
j. 10 μs .....	G;			
k. 1 μs .....	G:			
l. 100 nsec .....	G9			
m. Min .....	G5			
<b>3A. Display Position</b> (Digits from E in Data String) (Digit Position Defined from Right to Left, Decimal Point on Right Side of Digit)		<b>8. Remote Gating</b>		
a. 0 Digits .....	D;	a. Enable Rear Panel External Gate .....		
b. 1 Digit .....	D:	b. Disable Rear Panel External Gate .....		
c. 2 Digits .....	D9			
d. 3 Digits .....	D8	<b>9. Sample Rate</b> (Wait Time Between Measurements)		
e. 4 Digits .....	D?	a. Not Hold .....		
f. 5 Digits .....	D>	1. Min Time (1-5 msec) ..... E< or		
g. 6 Digits .....	D=	2. ≈50 msec time (Required for Start Function) .....		
h. 7 Digits .....	D< or D<*	b. Hold .....		
i. 8 Digits .....	D3	1. Take a measurement .....		
j. 9 Digits .....	D2			
k. 10 Digits .....	D1	<b>10. Accum Mode Start/Stop</b>		
l. Auto Position + .....	D0	A+B .....		
Auto Suffix		A-B .....		
Multiplier				
<b>3B. Display Multiplier Suffix</b>		<b>11. Slope</b>		
<b>FREQ.</b>	<b>PERIOD TIME INTERVAL</b>	<b>START/RATIO</b>	<b>ASCII</b>	<b>NOTE</b>
GHz	nsec	G	C7	On power up, these levels are random.
MHz	μsec	M	C6	Trigger Level in Voltage = $\frac{DDD}{250} - 2.000$ for $000 < DDD$
kHz	msec	k	C5	AND
Hz	sec		C4	A Chan A:00 = +2.000
mHz	ksec		C3	B Chan B:00 = +2.000
<b>4. Reset</b>				<b>NOTE</b>
a. Machine reset .....			I1	These codes are useful when calibrating the DAC
b. Remote Program Initialize .....			I2	
<b>5. Input Amplifier Control</b>				
a. COM A or Separate .....			E7	*For 9820A/9821A Calculators
b. Check .....			E?	**Codes have different function for Option 011
<b>RESET PUSHBUTTON/POWER UP/I2 PROGRAM conditions are F0, G0, D0, E7, E0, E2, E3, E1, E4, E5</b>				

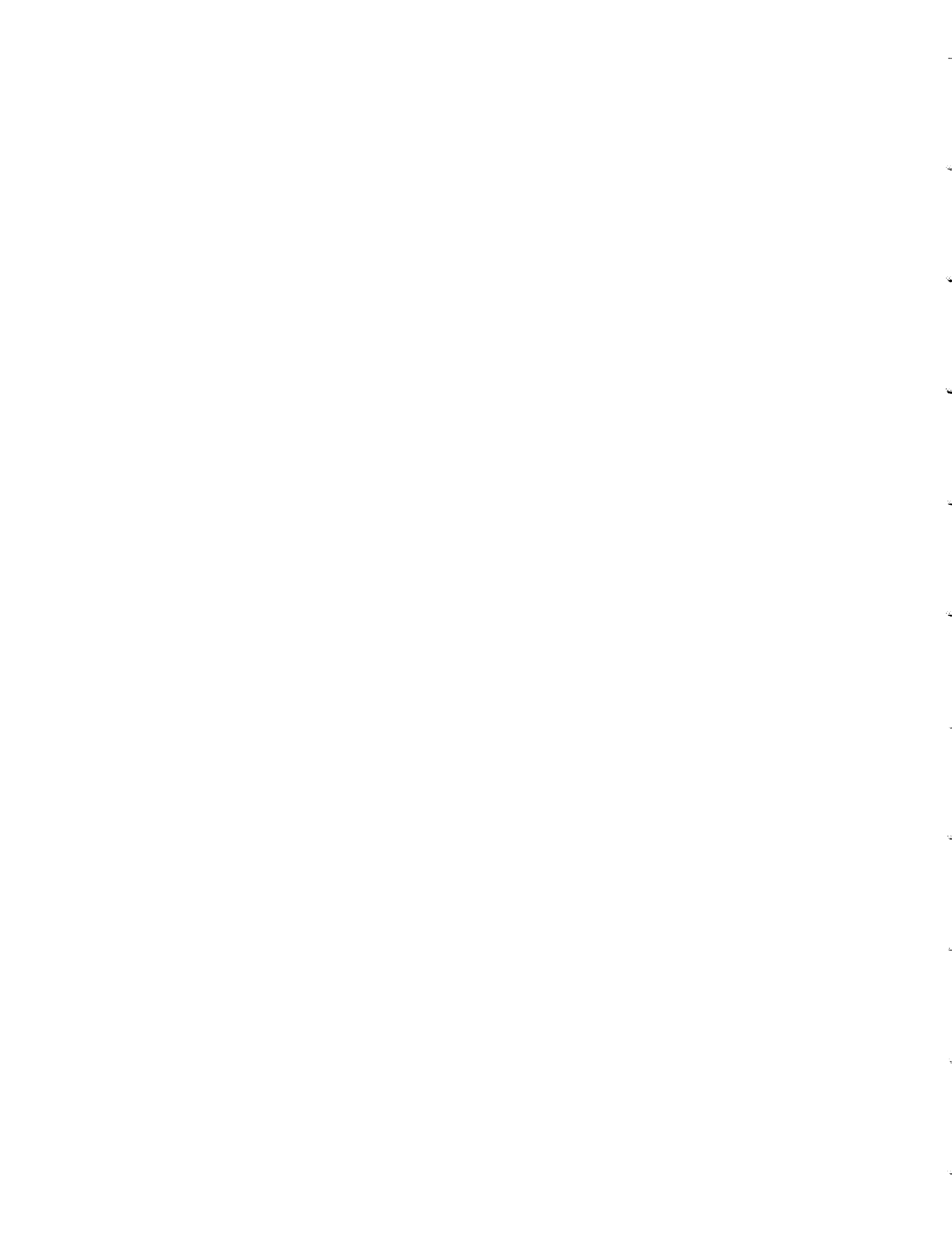

Table 2-5. Universal Commands for Model 5345A Option 012\*

ASCII CHARACTER	OCTAL CODE	REMARKS	5345A RESONSE
SOH	001	(GTL) Go To Local Included	Causes instrument to return to local if addressed to Listen
BS	010	(GET) Group Execute Trigger	Causes instruments on the bus (that are addressed to listen) to execute their function
DC1	021	(LLO) LOCAL Lockout	Disables the LOCAL pushbutton on the front panel
DC4	024	(DCL) Device Clear	Causes instrument to reset, same as instruction I1
CAN	030	(SPE) Serial Poll Enable	Controller places the bus in the serial polling mode
EM	031	(SPD) Serial Poll Disable	Controller terminates the serial polling mode.
?	077	(UNL) Unlisten	Clears or removes all addressed listeners from the active state of being addressed
_____ (underscore)	137	(UNT) Untalk	Underscore is used to clear the addressed talker from the active state of being addressed

NOTE: For additional information refer to User Guide manuals for 9820A, 9821A Calculators (HP 59300-90001) and 9830A Calculator (HP 59300-90002).

2-61. Output Process

2-61. When addressed to TALK, the 5345A outputs according to the program (Local or Remote), provided there is an addressed listener on the bus. The transfer routine, necessary for passing information on the data lines, cannot be started unless there is both an addressed listener and talker on the bus. The listener must be able to recognize LF (line feed) as the end of the 5345A's output data. As soon as the listener accepts LF (sets NDAC high) the 5345A leaves the output phase and continues through its operating cycle.

2-62. The output characters, their description, and the order in which they are outputted are shown in Table 2-6.

Table 2-6. 5345A Output Code Set

ORDER OUTPUTTED	CHARACTER	DESCRIPTION
1	( ) or (-)	Normally a space, minus when B is greater than A in start function.
2	0-9	0 to 11 digits may be outputted depending on Gate Time selection, most-significant-digit first.
3	.	Decimal Point.
4	E	Exponent Multiplier.
5	+ or -	Sign of Exponent Multiplier.
6	0, 3, 6, or 9	Multiplier.
7	CR	Carriage Return.
8	LF	Line Feed (used as a word terminator).

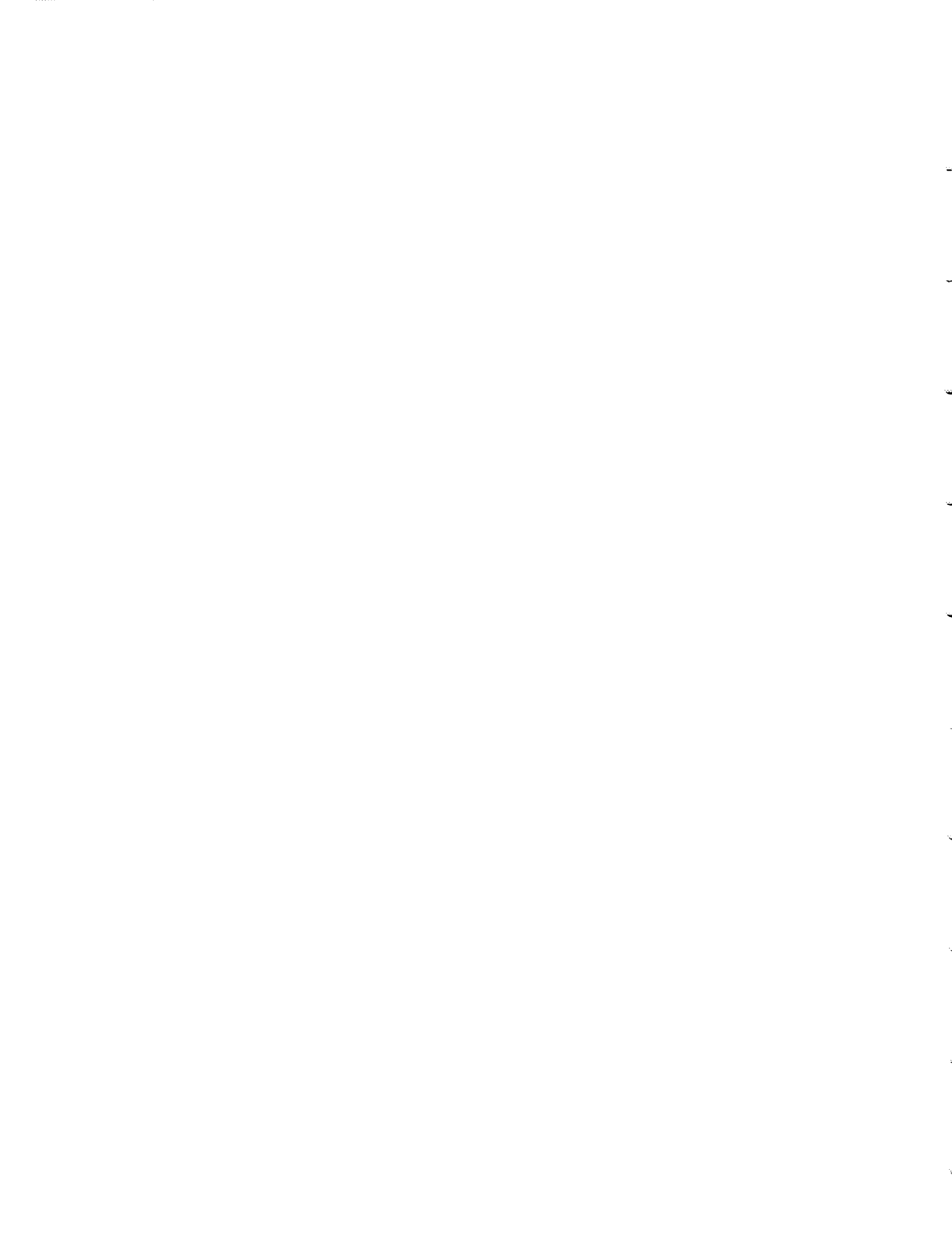

**2-54. Modes of Operation (Option 011 Only)**

2-55. The 5345A has several remote operating modes. They depend on the Sample Rate and Output modes and the method used to initiate a measurement procedure. This section includes a description of these modes and sample programs.

2-56. The two principal modes of remote operation, based on the Sample Rate and Output modes, are described in (a) and (b) below. Modes (c) and (d) are possible by selecting the remaining combinations of the Sample Rate and Output modes.

- a. Sample Rate NOT HOLD (E1) and Output ONLY IF E2
  1. If not addressed to talk, the 5345A continuously makes measurements at a rate determined by program codes "E<" or "E4" 1-5 msec or  $\approx$  50 msec, respectively plus measurement time. It skips the output phase of its operating cycle.
  2. If 5345A is addressed to TALK, it no longer skips its output phase. The next and all subsequent measurements are outputted.
- b. Sample Rate HOLD (E9) and output mode WAIT until addressed (E:) the 5345A sequence is:
  1. Addressed to LISTEN.
  2. Instructed to make a measurement.
  3. Makes a measurement and stops in its output phase.
  4. Addressed to TALK.
  5. Outputs and stops in its Sample Rate phase.
  6. Addressed to LISTEN.
  7. Instructed to make measurement, then repeats 3 through 6.
- c. Sample Rate NOT HOLD (E1) with (E<) or (E4) programmed and WAIT until addressed (E:) the 5345A:
  1. Makes a measurement and stops in its output phase.
  2. Is addressed to TALK.
  3. Outputs, goes through its sample rate, and makes another measurement and if:
    - (a) Still addressed to TALK, it repeats 3.
    - (b) Not addressed to TALK, it stops in its output phase and waits until so addressed, then repeats 3.
- d. Sample Rate HOLD (E9) and Output ONLY IF addressed (E2) the 5345A is:
  1. Addressed to LISTEN.
  2. Instructed to make a measurement.
  3. Makes the measurement and if:
    - (a) Addressed to TALK by the end of the measurement phase, it outputs and stops in the Sample Rate phase until 1 and 2 are repeated.
    - (b) Not addressed to TALK by the end of the measurement phase, it skips output and stops in the Sample Rate phase until 1 and 2 are repeated.

**2-57. Starting a Measurement Procedure (Option 011 Only)**

2-58. When operating the 5345A under remote control, a measurement procedure may be initiated by sending a Reset or Take a Measurement Instruction or by letting the sample rate time run out.

- a. Sample Rate NOT HOLD (E1) - a measurement starts at the end of sample rate time.
- b. Reset Instruction (I1):
  1. Can be given at any time during a 5345A's operating cycle.
  2. Does not change the information in the program storage cells.
  3. Clears the display.
  4. Arms the counter.
  5. Starts measurement phase of the 5345A's operating cycle.

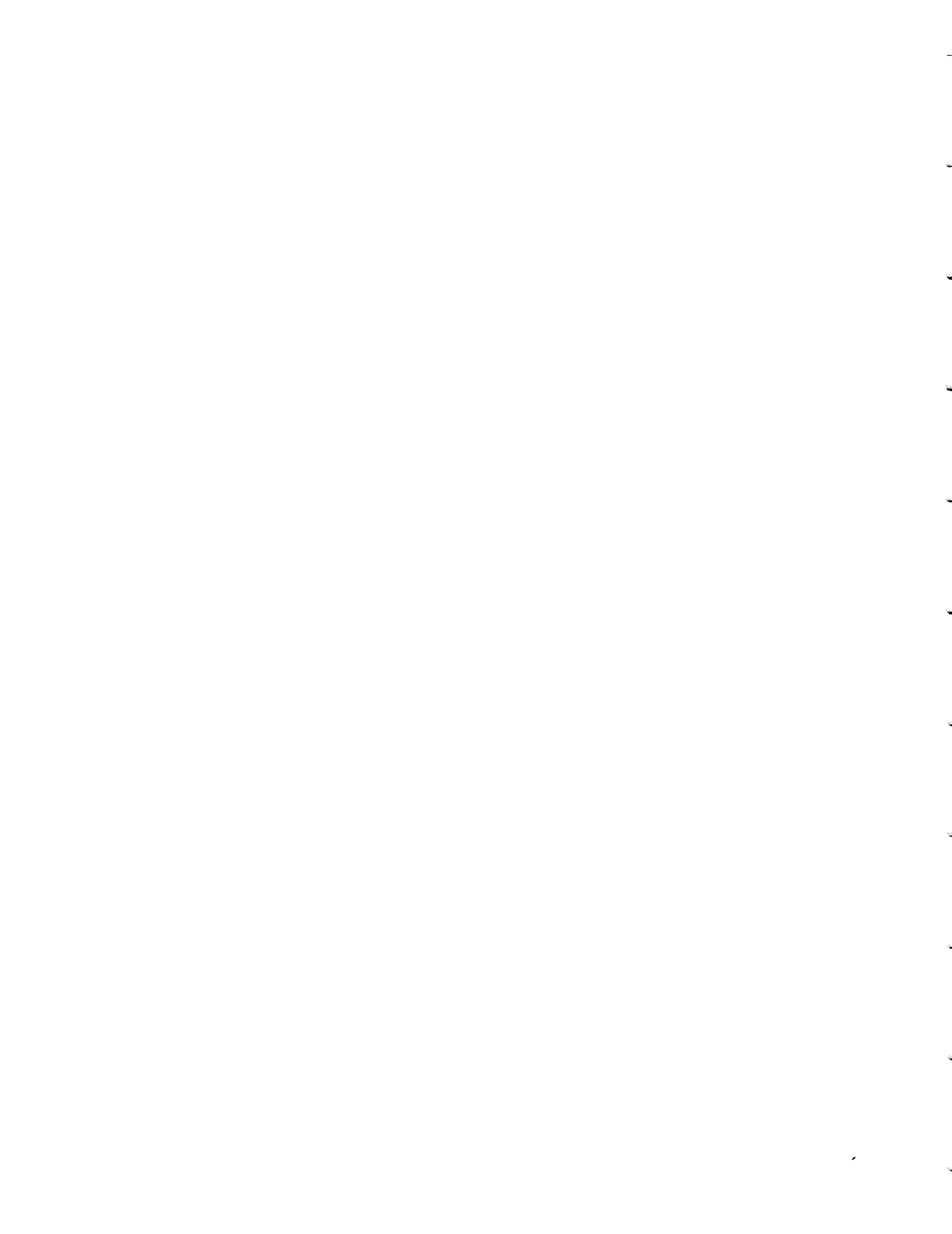



- c. Take a Measurement Instruction (J1):
1. Can be given only if the 5345A is stopped in the Sample Rate phase of its operating cycle. If given at any other time it will be ignored by 5345A.
  2. Does not change the information in the program storage cells.
  3. Does not clear the display.
  4. Starts the measurement phase of the 5345A's operating cycle.

**2-58. Examples of Programming (Option 011 Only)**

**2-60.** The following example shows 5345A and 9820A calculator programmed to instruct the counter to measure its 100 MHz check in a frequency mode at a 1-second gate time. The check frequency will also be recorded at 1-second intervals on the calculator printer.

**Equipment Required:**

- Model 5345A Counter with Option 011.
- Model 9820A Calculator with ASCII Bus Interface Model 11144A-020

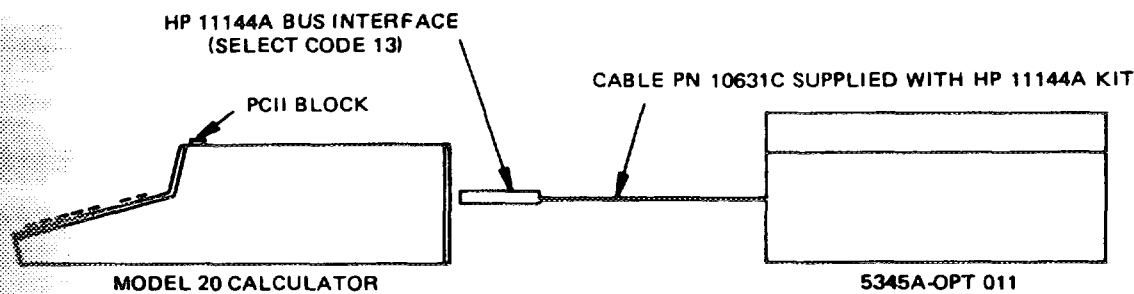

**NOTE**

Set ASCII address switches on the rear panel of the 5345A to positions 1001. Set TALK ONLY/ADDRESSABLE switch to ADDRESSABLE.

**2-61. LOADING THE PROGRAM.** Prior to loading the program, push the END and EXECUTE keys. This positions the program counter to zero. Push the remaining keys in the program, as shown in the calculator key column of Table 2-7.

**Table 2-7. Program Example**

Program Line No.	Commands	Program Description (Function)	Calculator Key
0	CMD	Control statement. Refer to 11224A peripheral control II operating manual HP Part No. 09820-99024 Pg. 2-11.	Bus Command
1	"	First quotes following CMD statement specifies address mode.	"
2	?	Unaddresses all listeners on the Bus.	?
3	U	Calculator talker address.	U
4	2	5345A listen address, commands 5345A to listen.	2
5	"	Terminates address mode.	"
6	,	Delimiter between modes (address and data).	,
7	F0	Second quote field specifies data program mode. Program code for frequency A (see 5345A program code sheet for all 5345A programming).	F
8	G0	Program for 1 sec gate time.	G
9	D0	Program for auto display position.	D
10	E?	Programs 100 MHz check.	E
11	E9	Programs sample rate to hold mode.	?
12	I1	Programs 5345A reset command. Resets previous reading, generates 100 ms reset pulse, and end of pulse initiates measurement cycle.	E
			9
			I
			1

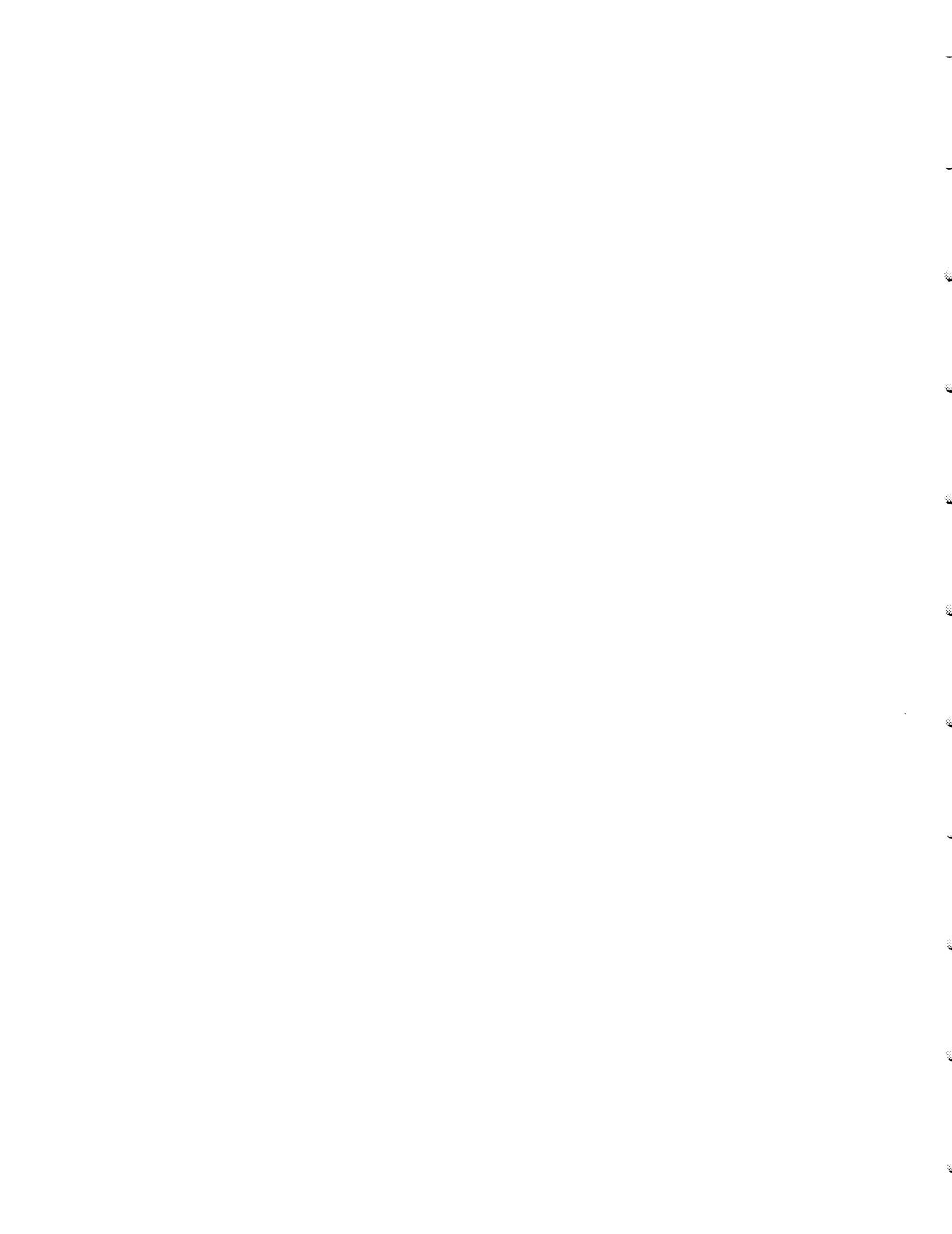

Model 5345A  
Installation and Remote Programming

Table 2-7. Program Example (Continued)

Program Line No.	Commands	Program Description (Function)	Calculator Key
0	E8	Programs 5345A to remote mode.	E
0	"	Terminates data mode.	8
0	,	Delimiter between modes.	"
0	"	Specifies address mode.	,
0	?	Unaddresses all listeners on the bus.	?
0	R	5345A talk address commands 5345A to talk.	R
0	5	Calculator listen address commands, calculator to listen.	5
0	"	Terminates address mode.	"
0	;	End of statement delimiter which terminates bus command program.	;
0	FMT *	Defines free-field format, refer 11224A peripheral control II operating manual HP Part No. 09820-99024, Page 2-6.	Format *
0	;	End of statement delimiter.	;
0	RED 13,A	Reads data on the bus through the 1144A-020 calculator interface card to the "A" register in the calculator. See HP 1144A-020 manual for more information (the first reading due to I1 command is all zeros).	Read 1 3 A
0	STORE	Stores program line 0 into calculator storage.	Store
1	CMD	Control statement. Refer to 11124A operating manual.	Bus Command
1	"	Specifies address mode.	"
1	?	Unaddress all listeners on the bus.	?
1	U	Calculator talker address commands calculator to talk.	U
1	2	5345A listen address, commands 5345A to listen.	2
1	"	Terminates address mode.	"
1	,	Delimiter between modes.	,
1	"	Specifies data program mode.	"
1	J1	Measure command to 5345A.	J 1
1	"	Terminates data mode.	"
1	,	Delimiter between modes.	,
1	"	Specifies address mode.	"
1	?	Unaddresses all listeners on the bus.	?
1	R	5345A talk address commands 5345A to talk.	R
1	5	Calculator listen address, commands calculator to listen.	5
1	"	Terminates address mode.	"
1	;	End of statement delimiter.	;
1	FMT *	Defines free-field format refer 11224A manual.	Format *
1	;	End of statement delimiter.	;
1	RED 13,A	Reads data on the bus through the 11224A-020 calculator interface card to the A register in the calculator (reads second and all successive readings to calculator A register).	Read 1 3 A
1	;	End of statement delimiter.	;
1	FLT 8	Specifies eight digits to the right of the decimal point on the calculator display. (Refer to calculator operating and programming manual, HP Part 09820-99001, Page 5-11 for more information.)	Float N 8
1	;	End of statement delimiter.	;
1	DSP A	Places contents of "A" register into the display (in this example, 100 MHz check frequency).	Display A
1	;	End of statement delimiter.	;
1	PRT A	Prints contents of "A" register on calculator printer (100 MHz check).	Print A
1	STORE	Stores program line 1 into calculator storage.	Store
2	GO TO 1	Calculator program steps to program line 1 executes the program.	GO TO 1
2	STORE	Stores program line 2 into calculator storage.	Store
3	END	Ends program.	END
3	STORE	Stores program line 3 into calculator storage.	Store

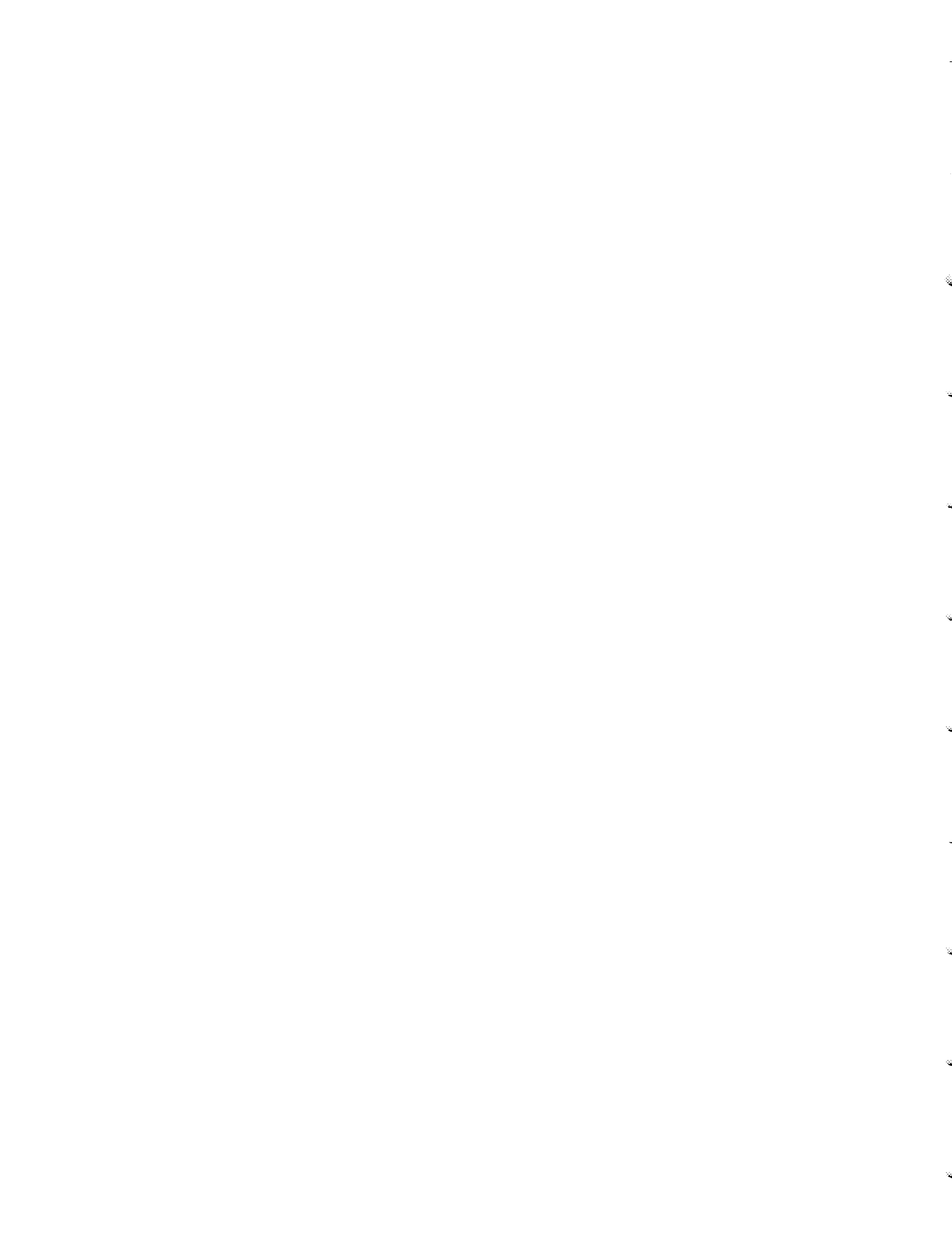



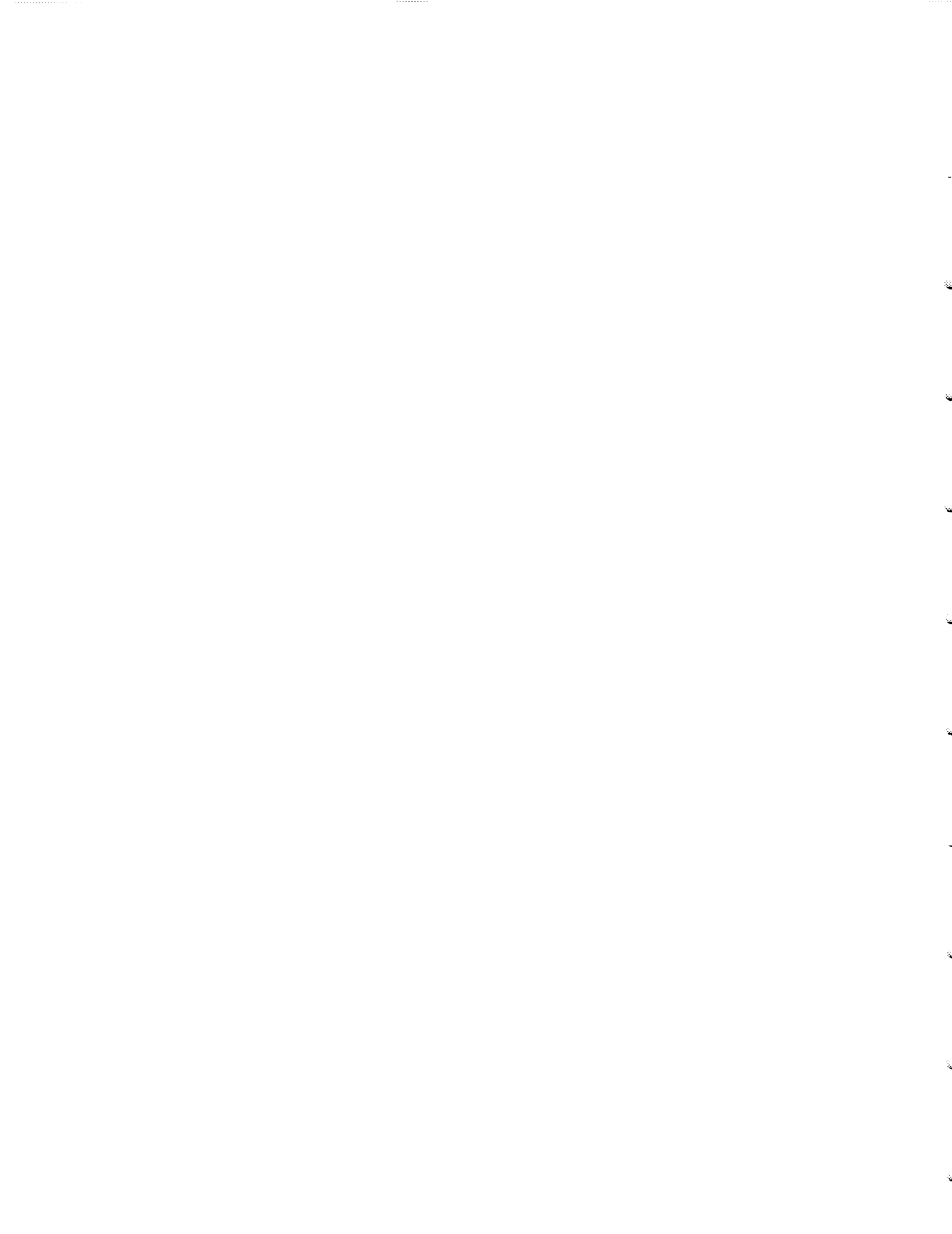

Model 5345A  
Installation and Remote Programming

2-64. RUNNING THE PROGRAM. To run the program push the END and RUN PROGRAM keys. The program and printer continue to run until the STOP key is pushed. The printout should compare to the sample 100 MHz PROGRAM output shown above. This completes the test program.

2-65. Another example of programming is with a Hewlett-Packard Model 3260A Mark Sense Card Reader. Assume that it is desired to program a 5345A for a period measurement, 100 ms gate time, auto display position, and 100 MHz check. The Remote Program, Initialize Code I2 will be used in this example so only those program codes which differ from the initialize code will be issued. See previous page for example.

**2-66. Option 012 Factory Installed Remote Programming**

2-67. Option 012 provides all the features of Option 011, plus remote programming of the input amplifiers' slope and level controls. Option 012 also uses several universal commands, and responds and identifies to the serial polling.

2-68. Option 012 has two D/A converters that permit the reference voltage presented to the input amplifiers to be controlled in 4 mV steps from -2.0V to +1.3V. The input amplifier does *not* have a trigger accuracy of 4 mV with Option 012.

**NOTE**

Trigger level range is linear from -2.0V to +0.5V with 4 mV resolution.

**2-69. Features**

2-70. The following are special operating features of the Option 012:

- a. Slope Control. The slope can be controlled externally.
- b. Trigger Levels. The trigger levels are set sending a channel select code and three digits, as:  
    ADDD  
    or  
    BDDD
  1. The actual trigger level will be:  
        
$$\frac{DDD}{250} - 2.000 \text{ volts}$$
  2. There is no defined power up state for the trigger levels.
  3. Trigger levels stabilize only when the last character is received from the Bus.
  4. Trigger level DAC's can be adjusted according to the procedure outlined in Table 5-6.
  5. A RESET code command (I1) should be sent to the counter after setting the DAC levels to prevent miscounts.

**2-71. Special Programming Considerations (not in Option 011)**

2-72. The following programming features must be considered when using Option 012:

- a. SRQ Identified Serially.
- b. Slope Controlled (must be Programmed).
- c. Levels Controlled (must be Programmed).
- d. LLO (Local-Lockout) Universal.
- e. GTL (Go to Local) Universal Addressed.
- f. DCL (Device Clear) Universal.
- g. GET (Trigger) Universal Addressed.

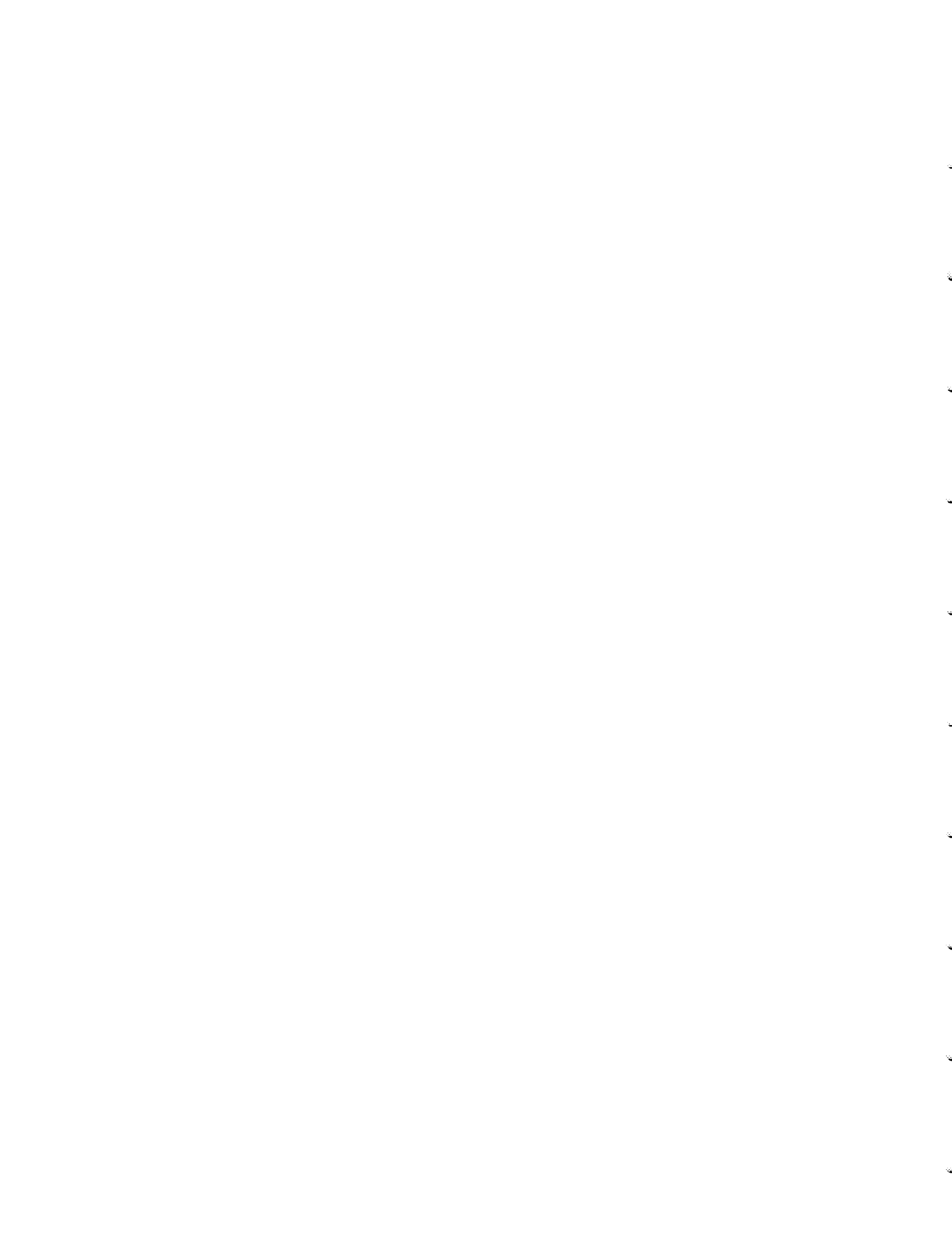



- h. All other codes same except E0, E8 which have different functions for Option 011.
- i. Goes to Remote anytime the counter is addressed to listen.

**NOTES**

1. Counter should be RESET with I1 command anytime a program code is sent to the counter. The I1 command should be the last command sent, so as to prevent miscounts.
2. Slope and Trigger Level codes should be sent to the counter when first programming the counter after a power up of the counter.
3. Manual Trigger Level controls should be set to RESET position when in REMOTE control to prevent interference to the remote levels."

**2-73. 5345A Option 011 with 9820A/21A Calculator Programming Summary**

a. **ADDRESS MODE SELECTION** - Set the rear panel TALK ONLY—ADDRESSABLE switch as follows:

1. To TALK ONLY if the 5345A is to operate according to its front panel controls and is to transfer measurement data to one or more listener devices on the bus.
2. To ADDRESSABLE if the counter is to be addressed to talk or listen. In this mode, the counter can be remote programmed when addressed to listen and can send measurement data to the controller or other devices when addressed to talk.

b. **ADDRESS ASSIGNMENT** - In ADDRESSABLE, the counter's bus address is established by setting rear panel switches A5—A2 as shown in Table 2-8 on the next page. Each combination of switch positions results in a unique talk address, a unique unprocessed output format talk address (computer dump mode is the shaded talk address), and two listen addresses (the counter will respond to either one).

c. **REMOTE OPERATION** - To cause the counter to operate according to the program codes stored in the remote program cells, the bus must be in the Remote Enable state AND the counter must have been sent the ASCII code pair E8. To put the bus in the Remote Enable state, execute the statement: FMT Y3,Z; WRT 13. If the bus is in the Remote Disable state or if the ASCII local code E0 is stored in the counter, the counter will operate according to the front panel controls. To put the bus in the Remote Disable state, execute the statement: FMT Y4,Z; WRT 13. To switch to local if in remote, send the E0 code or push the reset button. (NOTE: The 9820A/9821A calculator powers up in the Remote Enable state.)

d. **SETTING REMOTE PROGRAM CODES**

**Statement Format:** CMD "ADDRESS STRING," "DATA STRING;"

**Example:** CMD "?U\*," "I2E8E?G?I1"

**Explanation:** CMD is what the calculator displays when the BUS COMMAND key of PCII is pushed.

The first quote field defines the ADDRESS MODE of bus operation. The unlisten command (?) disables all listeners on the bus and should be first in the address string so as to avoid sending data to unwanted listeners which may have been previously addressed. The controller then designates itself as the talker (U) and designates the counter as the listener (\*) (assuming counter address switches have been set for talk address of J, listen address of \*). The calculator has a talk address of U and a listen address of 5 since the ASCII Bus Interface Card was preset to these codes before leaving the factory (see the ASCII Bus Interface Manual page 1-1). The second quote field defines the DATA MODE. One ASCII code pair from each of the 13 code groups shown in Table 2-3 may be selected. The ASCII characters are sent in a byte serial fashion from left to right in the statement. In the example, I2 causes the remote program initialize to be selected which causes the program storage cells of the counter to be initialized with the conditions: F0, G0, D0, E7, E0, E2, E3, E1, E4, E5. The codes after I2 make changes to the I2 conditions: E8 selects remote control, E? selects the check signal and G? selects a 100 msec gate time. Reset pulse I1 (100 ms) is sent to ensure start of a measurement cycle (at end of pulse) using the new program codes. Of course, the same result would have been obtained by sending "F0G?D0E?E8E2E3E1E4E5I1."

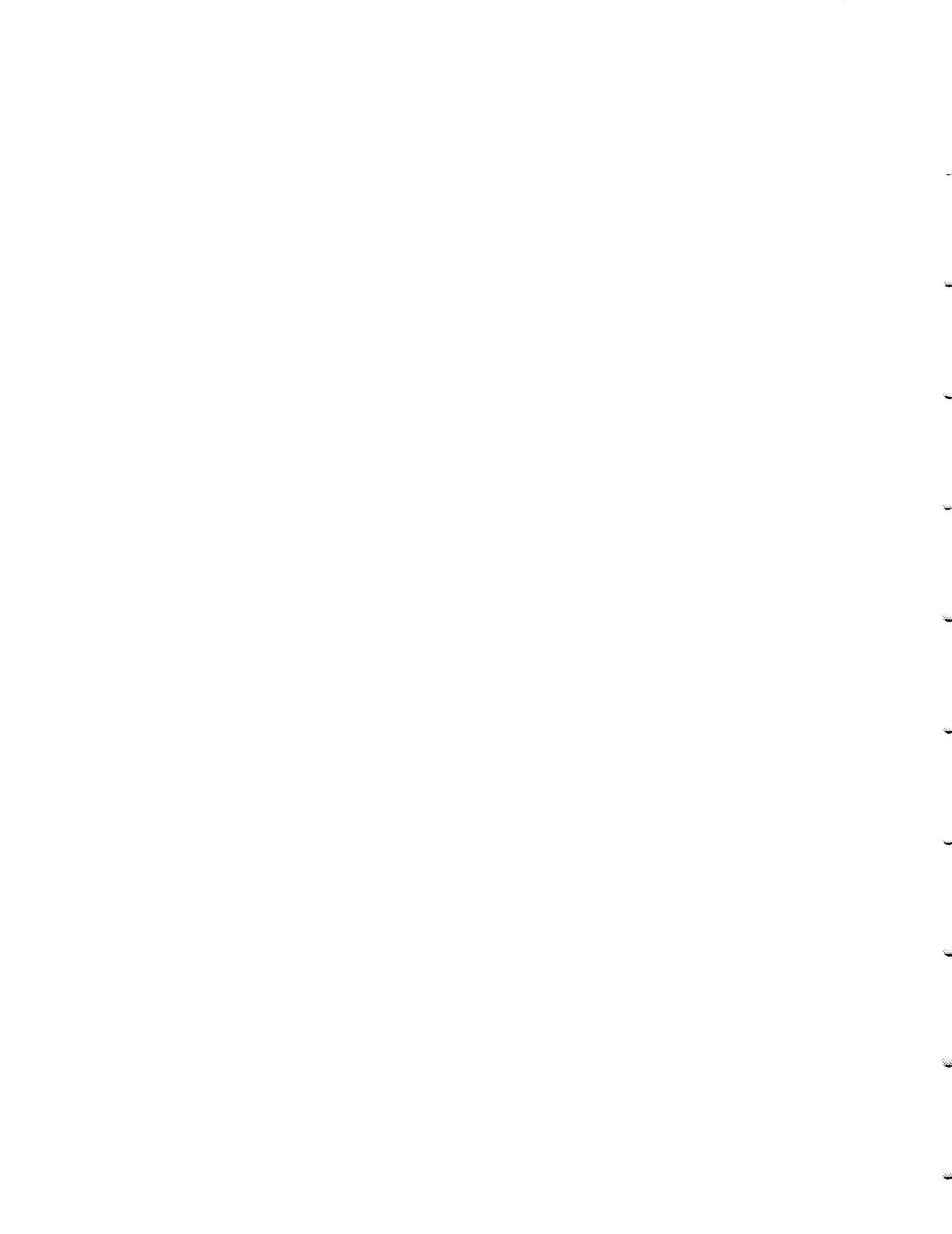

e. SETTING REMOTE PROGRAM CODES USING 49 WRITE BYTE

**Statement Format:** CMD "ADDRESS STRING"; FMT Y2,Z; WRT 13; WTB 13, <register address>

**Example:** CMD "?U\*"; FMT Y2,Z; WRT 13; 70 → A; 49 → B; WTB 13, A; WTB 13, B

**Explanation:** It is sometimes useful to be able to send program codes which are the result of calculations in the program. This is most easily accomplished by using the WRITE BYTE key of PCII to send the decimal representation of an ASCII character. (Decimal equivalents of all the ASCII characters are given on page 2-8 of the PCII Operating Manual.) After the address information, the bus is put into the DATA MODE by executing FMT Y2,Z; WRT 13 (the bus may be put into the ADDRESS MODE by executing FMT Y1,Z; WRT 13). WTB 13,A writes out 70 (decimal equivalent to ASCII "F"). WTB 13, B writes out 49 (decimal equivalent to ASCII "1") onto the bus. The statements in the example are equivalent to performing CMD "?U\*", "F1."

f. TAKING A MEASUREMENT

**Statement Format:** CMD "ADDRESS STRING", "J1"

**Example:** CMD "?U\*", "J1"

**Explanation:** If the counter has been previously programmed for HOLD sample rate (E9), the Sample Trigger Command (J1) causes the counter to be armed thereby initiating a new measurement. In general, following the trigger command in the program are program statements to read the measurement into the calculator. To allow for the time lapse between the time of the sample trigger and the read statements, the counter should have been programmed for WAIT until addressed output mode (E:). Hence, before the J1 command, the counter should have been sent a sequence of ASCII codes which included the E9E: codes.

g. READING COUNTER MEASUREMENT INTO THE CALCULATOR

**Statement Format:** CMD "ADDRESS STRING"; FMT <format spec>; RED 13, <register address>

**Example:** CMD "?J5"; FMT\*; RED 13, A;

**Explanation:** FMT and RED are displayed by the calculator when the FORMAT and READ keys on PCII are respectively pushed. These should not be confused with similarly labeled keys on PCI. The contents of the quote field after the CMD define the counter as the Talker (assuming that the counter address switches have been set for a talk address=J, listen address=\*), and the calculator as the listener (listen address=5). The semicolon terminates the bus command statement. The FORMAT statement defines a free field format (see the

Table 2-8. Address Switches

ADDRESS SWITCHES					
A <sub>5</sub>	A <sub>4</sub>	A <sub>3</sub>	A <sub>2</sub>	Listen** Address	Talk Address
0	0	0	0	SP	@
0	0	0	1	!	A
0	0	0	1	"	B
0	0	1	0	#	C
0	0	1	0	\$	D
0	0	1	1	%	E
0	1	0	0	&	F
0	1	0	1	'	G
0	1	1	0	(	H
0	1	1	1	)	I
1	0	0	0	*	J
1	0	0	1	+	K
1	0	1	0	,	L
1	0	1	1	-	M
1	1	0	0	.	N
1	1	0	1	/	O
1	1	1	0	0	P
1	1	1	1	1	Q
1	1	0	0	2	R
1	1	0	1	3	S
1	1	1	0	4	T
1	1	1	1	5	U
1	1	0	0	6	V
1	1	0	1	7	W
1	1	1	0	8	X
1	1	1	1	9	Y
1	1	0	0	:	Z
1	1	0	1	;	[
1	1	1	0	<	]
1	1	1	1	=	

\*\*either listen address may be used.  
 Shaded talk addresses are computer dump  
 Talk codes only; cannot be used as Normal  
 Talk Output codes.



PCII manual, pages 2-5 to 2-10). The READ statement specifies that data is to be read from the device with select code 13 (the ASCII Bus Interface card) and is to be placed in register A of the calculator (see the PCII manual, page 2-4).

**h. READING COUNTER MEASUREMENTS INTO THE CALCULATOR USING UNPROCESSED FORMAT TALK MODE (COMPUTER DUMP)**

**Statement Format:** CMD "ADDRESS STRING"; RDB 13 - <register>

**Example:** CMD "?K5"; RDB 13-48 - X

**Explanation:** This talk mode was not intended for use with the calculator. If, while in computer dump talk mode, the 5345A is unaddressed and another device is addressed, upon readdressing the 5345A to talk, one bit of data will be lost (this doesn't occur when using the computer). If this situation is avoided, computer dump talk may be used and is useful in obtaining constant  $2 \times 10^{-9}$  resolution from the counter. RDB is what the calculator displays when READ BYTE on PCII is pushed. If the counter address switches were set for a talk address of J and a listen address of \*, the talk address for computer dump talk is K (always 1 bit greater than the normal talk code — see figure on the right). In the computer dump mode, 32 ASCII digits of information are output sequentially. Hence, the READ BYTE must be in a loop which is traversed 32 times. Each byte is read and converted to the decimal equivalent of the ASCII digit. In the above example, decimal 48 (decimal representation for 0 in ASCII) is subtracted from each byte, so that X contains a decimal number from 0 to 9. The 16 digits of the event scaler (from least significant to most significant) followed by the 16 digits of the time scaler (least significant to most significant) are output. The 5345A continues to output in this mode until it is unaddressed. The following figure on the right is a flowchart of a program which could be used to read the counter in computer dump output mode.

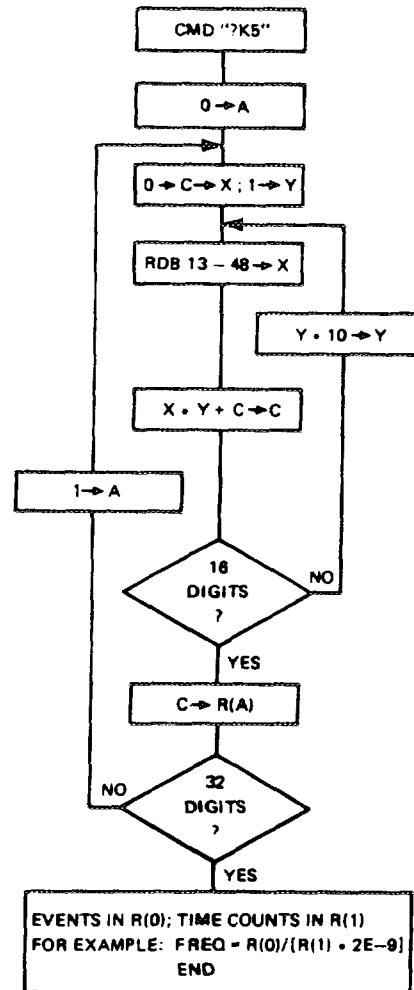

**2-74. 5345A Implementation of Bus Features**

**a. UNIVERSAL COMMANDS** - The 5345A Option 011 responds to the Untalk and Unlisten universal commands. It does NOT respond to the following universal commands: Local Lockout (LLO), Group Execute Trigger (GET), Device Clear (DCL), Serial Poll Enable (SPE), and Serial Poll Disable (SPD).

**b. SERVICE REQUEST TESTING**

**Statement Format:** If RDS 13 <1.9; GTO <STMT#>

**Example:** If RDS 13 <1.9; GTO 5

**Explanation:** RDS is what the calculator displays when the READ STATUS key of PCII is pushed. The 5345A pulls SRQ low (hence RDS 13 will be <1.9) after a measurement has been made only if it is in the "WAIT until address" output mode. The 5345A does NOT respond to serial polling. SRQ is cleared after the 5345A has been addressed to talk. If two or more 5345A's are connected to the bus and one of them sets SRQ low, the controller must sequentially address each to TALK. Only the 5345A with output information will respond.

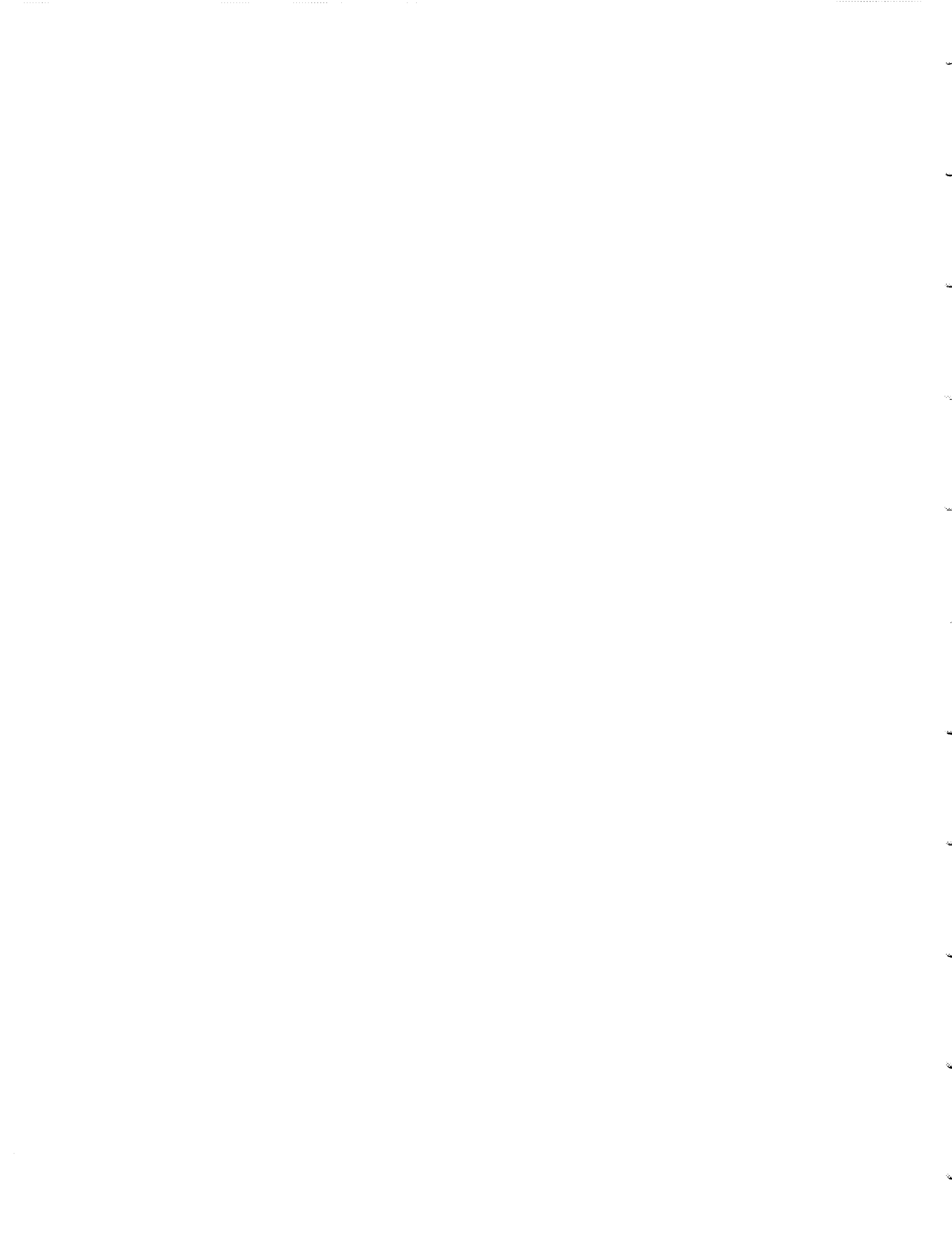

Model 5345A  
Installation and Remote Programming

**2-75. 5345A Typical Output Speed**

2-76. The following apply to both Option 011 and Option 010 (standard output format only).

Typical Through-put Rate:

a.	5345A—Superfast Computer .....	=9 kHz
b.	5345A—Usual Computer I/O .....	=1 kHz
c.	5345A/98XXA Calculator .....	=25 Hz
c.	5345A/5150A Printer .....	=3 Hz

The measurement cycle of the 5345A is the sum of several events.

- a. Measurement time (Gate Time).
- b. Process (compute) time.
- c. Output time on the HP Interface bus.
- d. Arming time to next measurement.
  1. **Measurement time** for CW frequency signal can be from 20 ns to 20,000 s.
  2. **Process time** for mainframe only (5345A), measurement will typically be 1 ms. For measurements involving plug-ins with complex arithmetic routine, the process time may be as long as 3 ms.
  3. **Minimum output time** is a function the total number of digits outputted. Seven characters plus some number of displayed digits (1 to n) are outputted per measurement in  $(23 + 11n) \mu\text{s}$ .
  4. **Arming Time** is variable from  $<1 \mu\text{s}$  to infinite (hold).

Output time occurs in parallel with arming time and measurement time. Thus, if the sum of arming time and measurement time exceeds output time, the effective output time is zero.

For the fastest possible measurement cycle rates: process, output, and arming are combined in the "computer dump" mode. **Total** minimum cycle time for the computer dump mode is

$$\text{Computer Dump Min.} = \text{Measurement Time} = 107 \mu\text{s}$$

For the standard output mode

$$\text{Standard Output Time} \approx 1 \text{ ms}$$

Remember that the output time is timeshared with arming and measurement time. Thus, if the 5345A is EXT ARM for the  $<1 \mu\text{s}$  arming time and if GATE TIME is  $>1 \text{ ms}$ , cycle time will equal to GATE TIME. **NOTE:** Plug-in measurement may add one or two more ms to the Standard Output Time.

Typically, system speed of outputting data from the 5345A is dictated by the receiver. **DATA LISTENERS** (receivers) are of two types:

- a. Non-programmable, such as:
  1. 59303A Digital-to-Analog Converter.
  2. 59301A HP Interface Bus to Parallel Converter.
  3. 5150A Thermal Printer.

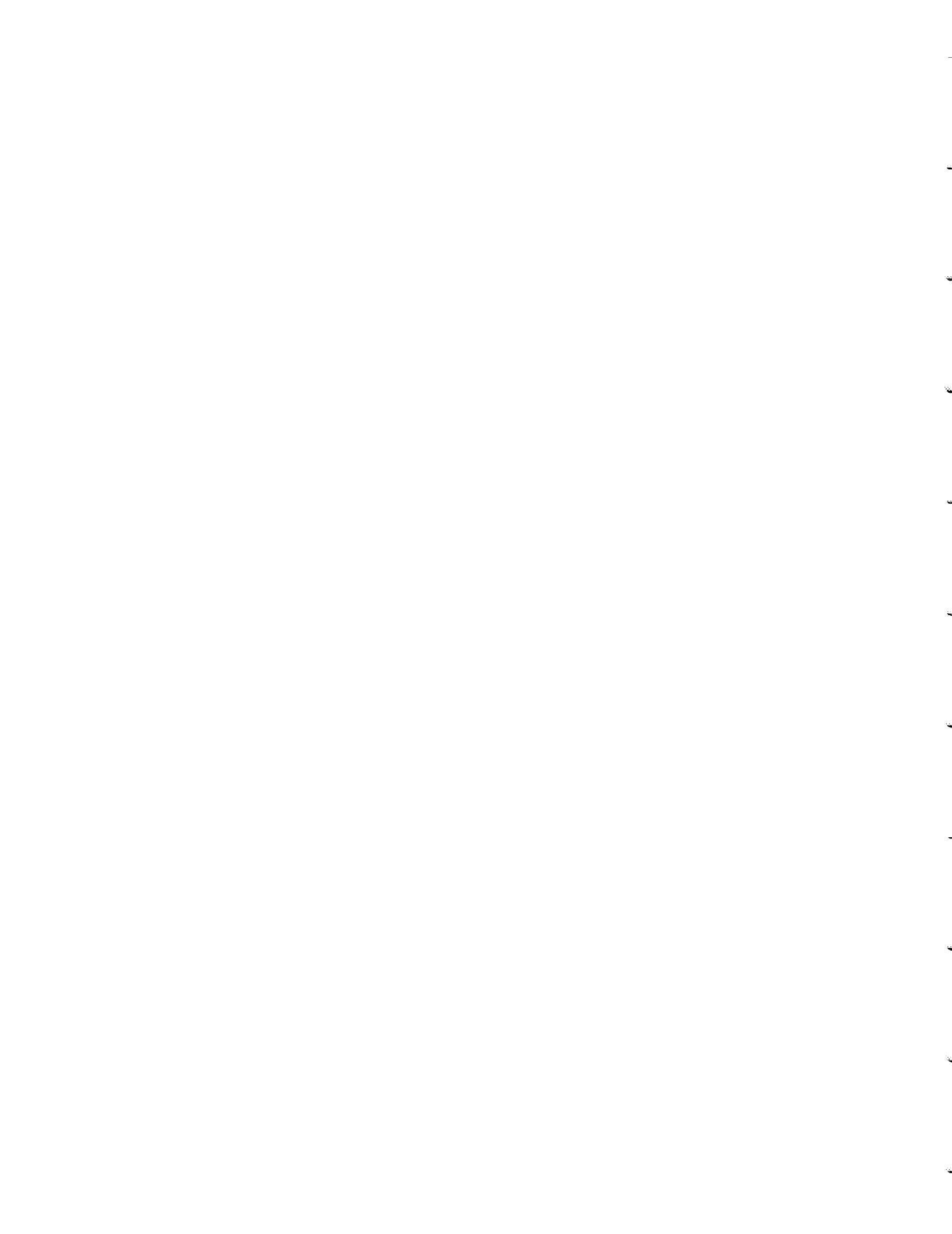



b. Programmable Data Receivers, such as:

1. 9820A Calculator.
2. 2105A Computer.

The data rate between the 5345A and type 1, non-programmable receivers is fixed for any given word length of "n" bytes. For any pair of sender-receiver on the bus, the rate of transmission is approximately equal to the rate of the slower machine. In fact, on the HP Interface Bus one may have several LISTENERS (Receivers). Of course, it is legal to have only one TALKER (sender). In this case the rate of information transmission is determined by the slowest instrument.

59301 Converter  $\approx 200\text{--}400 \mu\text{s}$  ( $25 \mu\text{s}/\text{byte}$ )  
5150A Terminal Printer Cycle Rate  $\approx 300 \text{ ms}$

For programmable receivers, the input data rate is determined by three factors: the hardware constraint, system firmware, and the programmers software. Typically the software and system firmware (pre-programmed internal software) is much more restrictive. The following example with the 5345A minimum GATE TIME and minimum ARM TIME will illustrate this. Let 5345A talk address = J and listen address = \*. Then:

a. 9820A — 5345A Operation

1. For reference: 5345A TALK, nobody LISTEN

CMD "J?"

Cycle time  $\approx 1 \text{ ms}$  (but useless because nobody listens)

2. 5345A TALK, 9820A LISTEN with no 9820A storage of data. 9820A storage of data. 9820A talk address = U, listen address = 5.

0: CMD "J?5"  
1: RED 13,A; JMP 0

Cycle time  $\approx 19 \text{ ms}$  (useless)

The extra 18 ms represent firmware restriction of the 9820A.

3. 5345A TALK, 9820A LISTEN and STORE DATA POINTS a minimum length program.

0: CMD "J?5", 1-C  
1: RED 13,R( )C; C+1-C  
2: IF C>300 GTO 4  
3: GTO 1  
4: STP

Cycle time  $\approx 35 \text{ ms}$

This program stores 300 readings in 300 9820A storage locations. The incremental 15 ms represent 9820A program execution line.

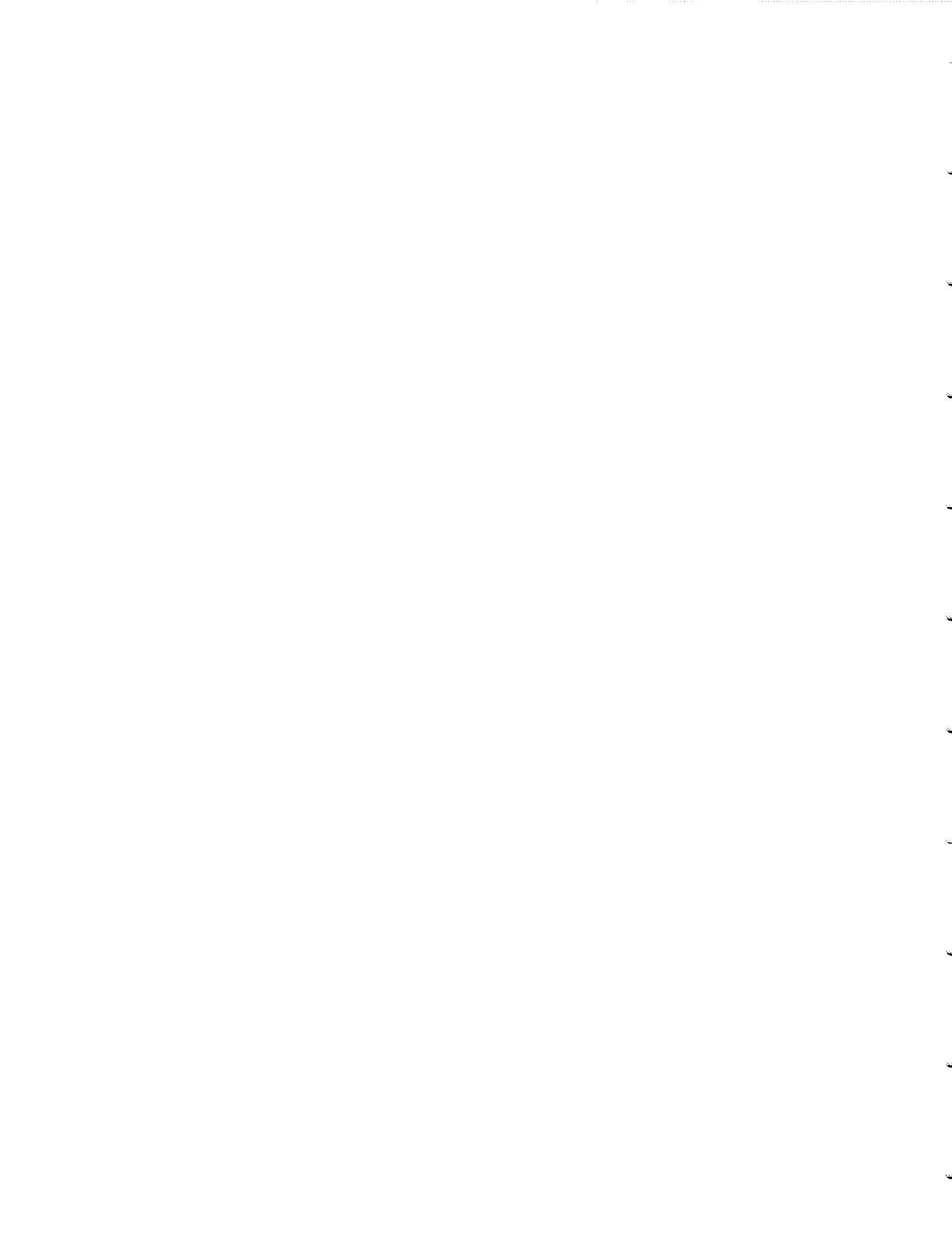

**Model 5345A**  
**Installation and Remote Programming**

b. 9830A—5345A Operation

5345A TALK, 9830A LISTEN with NO DATA STORAGE

10: CMD "J?5"  
20: ENTER (13,\*)A  
30: GO TO 20

Cycle time =18 ms (useless)

Program execution time for a useful program is similar to the 9820A (=35 ms).

- c. Even faster operation can be obtained with a calculator (9820A, 9821A, 9830A) with the following technique. Since the calculator spends much of its 35 ms in program execution time, it is possible to shorten this program loop and reduce input time by telling the calculator where to put the data instead of letting it figure it out itself.

0: CMD "J?5"  
1: RED 13,R1  
2: RED 13,R2  
3: RED 13,R3  
.  
.  
.  
300: RED 13,R300  
301: STP

This program stores 300 readings in almost twice the speed but with a program length of 302 steps vs. 5 steps in a3, above.

d. 2100A, 59310A—5345A

1. 5345A Computer Dump Mode — DMA LISTEN program Cycle time =107  $\mu$ s
2. 5345A Standard Output — variable computer software Cycle times 1—10 ms.

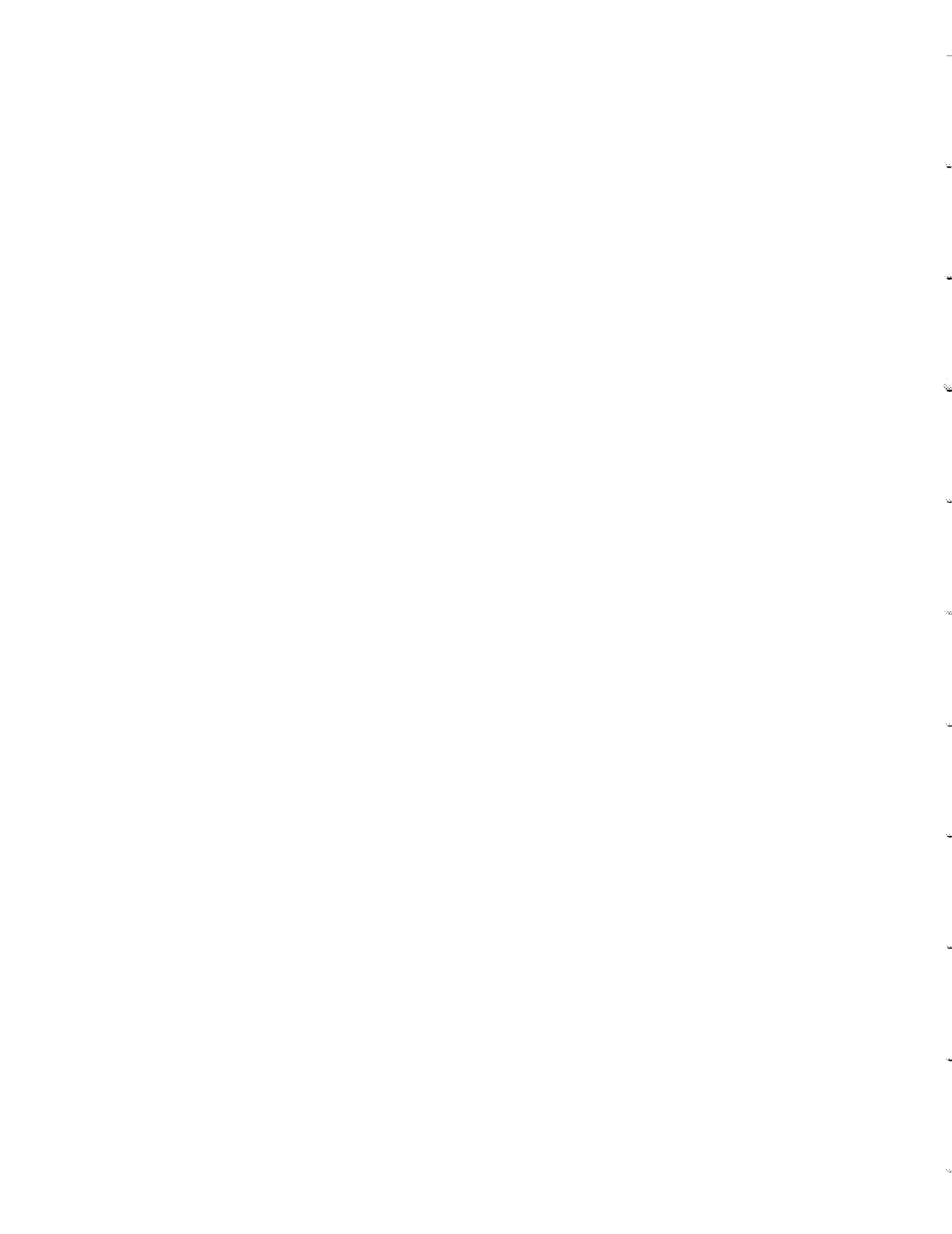

## SECTION III OPERATION

### 3-1. INTRODUCTION

3-2. Section III contains operating information that is helpful in realizing the best performance from the instrument. This includes a general description of the operating modes, the function of the controls and indicators, operator's maintenance, a self-check procedure, and setup procedures for making basic measurements.

### 3-3. MEASUREMENT TECHNIQUE

3-4. The counter uses a period average technique to make measurements. The counts (or pulses) that are generated from the input and time base signals are collected in separate scalers during the measurement time. The counter compares these pulses arithmetically and displays the result on the front panel.

### 3-5. OPERATING MODES

3-6. The following paragraphs describe the operating modes for frequency, period, time interval, ratio, and totalize measurements.

#### 3-7. Frequency Mode

3-8. Channel A accepts input frequencies from 50  $\mu$ Hz to 500 MHz with a minimum level of 20 mV rms sine wave. These frequencies are counted directly with no prescaling techniques applied. Extended frequency capability is available with the use of plug-ins. The counter is capable of measuring pulsed RF in either a single burst or an average of several bursts. The measurement time within the burst may be varied in length and position for detecting frequency variations within a burst.

3-9. The measurement time is the selected gate time plus the time until the next trigger pulse occurs. For example, if the selected gate time is 1 ms, the event gate will close on the next trigger pulse after 1 ms has elapsed. If the input frequency were 20 kHz (.05 ms period), the measurement time would be 1 ms + .05 ms = 1.05 ms. The difference encountered does not affect the accuracy of the measurement.

#### 3-10. Period Modes

3-11. Two modes of period measurements are available: single period and period average. These modes are described in the following paragraphs.

3-12. **SINGLE PERIOD.** Single period measurements are made with the GATE TIME switch set to MIN. In this position, the gate time is one period or 50 ns, whichever is greater. Therefore, the input frequency range for a single period measurement is 50  $\mu$ Hz to 20 MHz. Frequencies greater than 20 MHz may be applied, but they will be averaged during a 50 ns gate time.

3-13. **PERIOD AVERAGE.** When the GATE TIME switch is set to any other position than MIN, the counter averages multiple periods. Averaging increases the accuracy and resolution of the measurement. Input frequencies are in the 50  $\mu$ Hz to 500 MHz range. The actual gate time is determined in the same manner as that described under Frequency Mode.

3-14. Number of Periods Averaged. To determine the number of periods averaged during a measurement, divide the displayed answer into the selected gate time.

Example:

$$\frac{\text{Gate Time setting (sec)}}{\text{Displayed Period (sec)}} = \frac{1 \text{ ms}}{20.492 \mu\text{s}} = 48.799 = 49 \text{ periods}$$

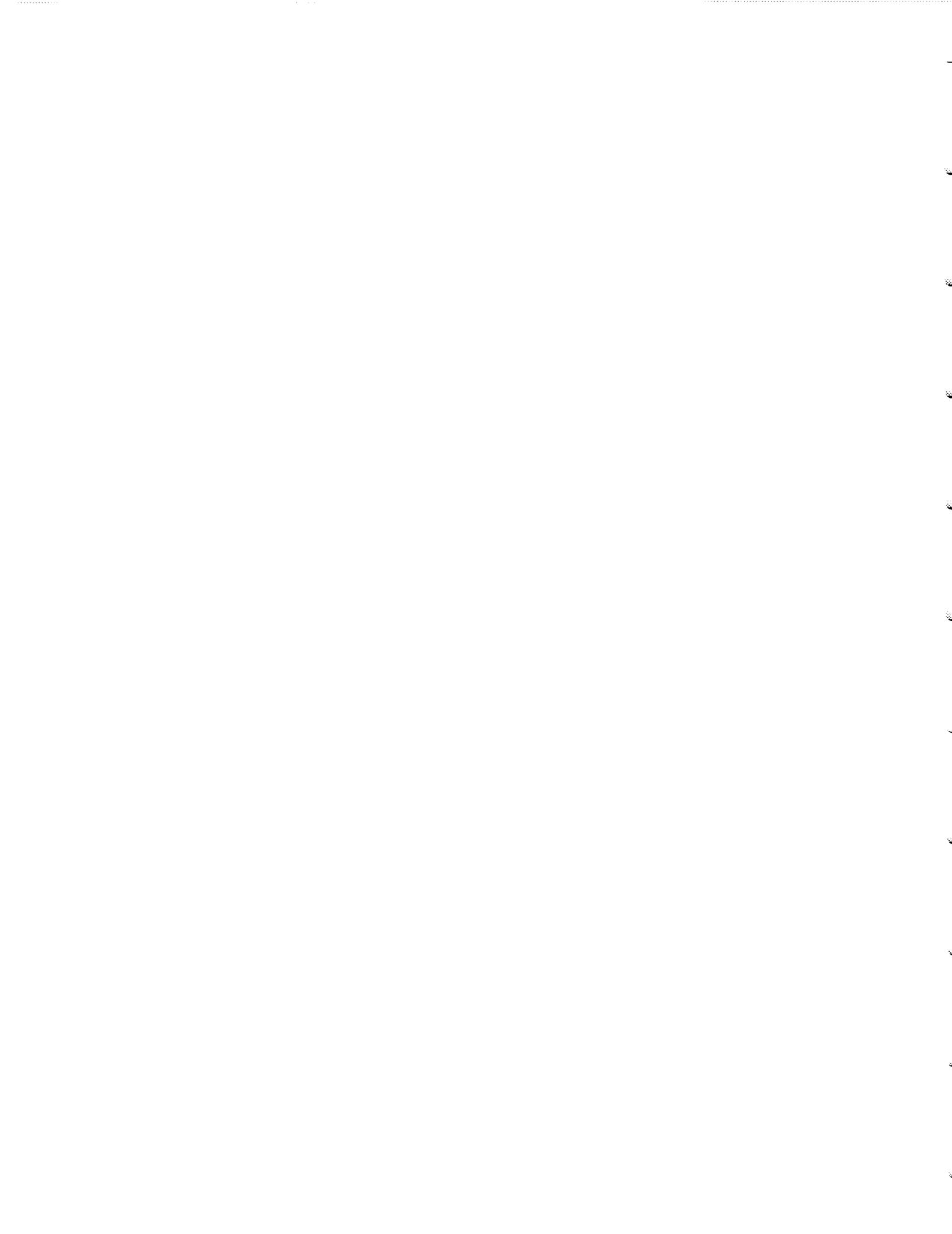

The number of periods averaged will always be a whole number. Therefore, should the calculated answer contain any digits to the right of the decimal point, drop these digits and increment the remainder by one. This is due to the extended gate time. The answer for this example, then, is 49 periods averaged.

### 3-15. Time Interval Modes

3-16. The counter measures time intervals from Channel A to Channel B; that is, Channel A starts the measurement and Channel B stops the measurement. Time between points on a single waveform can be measured by connecting the input signal to CHANNEL A jack and placing the Input Amplifier Control switch to COM A. Under these conditions, the slope and level controls of Channel A and Channel B allow variable triggering on either the + or - slope. With the Input Amplifier Control switch set to SEP, measurements can be made between points on separate waveforms.

3-17. SINGLE TIME INTERVALS. Single time intervals down to 10 ns are measured with the GATE TIME switch set to MIN. The gate time is one time interval for repetition rates of less than 20 MHz. Thus, if two or more time intervals occur within 50 ns, they will be averaged.

3-18. TIME INTERVAL AVERAGE. The counter averages multiple time intervals when the GATE TIME switch is set to any position other than MIN. The maximum repetition rate is 50 MHz (10 ns time interval plus 10 ns deadtime = 20 ns period or 50 MHz). To average, the time interval must be less than the selected gate time.

#### NOTE

If the time interval is greater than the gate time, but not more than 3.5 times greater, a single period will be measured. The MIN gate time position is preferred for single periods.

3-19. When averaging, white noise modulates the internal clock signal to prevent any harmonic relationship between the input signal and the clock. This increases the measurement accuracy. The noise is not generated when the GATE TIME switch is set to MIN.

3-20. INITIATING A MEASUREMENT. The front-panel ARM and GATE lights and the rear-panel dc trigger levels are helpful when setting up a time interval measurement. Place the GATE TIME switch to 100  $\mu$ s. The ARM light is an indication that Channel A is not triggering, possibly due to insufficient signal amplitude or misadjusted front-panel controls. A flashing GATE light indicates that Channel A is triggering. If the counter is gating and lamp test (paragraph 3-63) is flashing or appears to be steady, the counter has gone into excessive gate time (paragraph 3-36). This means the counter has reset because Channel B was not triggered with a stop signal. This could be caused by the stop pulse failing to arrive until after the maximum allowable time, which is 3.5 times the selected gate time. In this case, increase the gate time. Other causes could be insufficient signal amplitude or misadjusted front-panel controls.

3-21. MEASUREMENT TIME. In time interval average, the time needed to complete a measurement may be much longer than the selected gate time. This is because the counter collects a gate time's worth of time intervals. The factors which would increase the measurement time are short time intervals and extended time between intervals (see Figure 3-1).

3-22. Occasionally, when increased resolution is needed, it may be convenient to estimate the total time of a measurement. To calculate this, use the equation below.

$$\text{Measurement Time} = \frac{\text{Gate Time (sec)}}{\text{Time Interval (sec) X Number of Time Intervals per sec}}$$

$$\text{Example: } \frac{1 \text{ msec}}{100 \text{ ns X } 800/\text{sec}} = \frac{1 \text{ X } 10^{-3} \text{ sec}}{8 \text{ X } 10^{-5}} = 12.5 \text{ seconds}$$

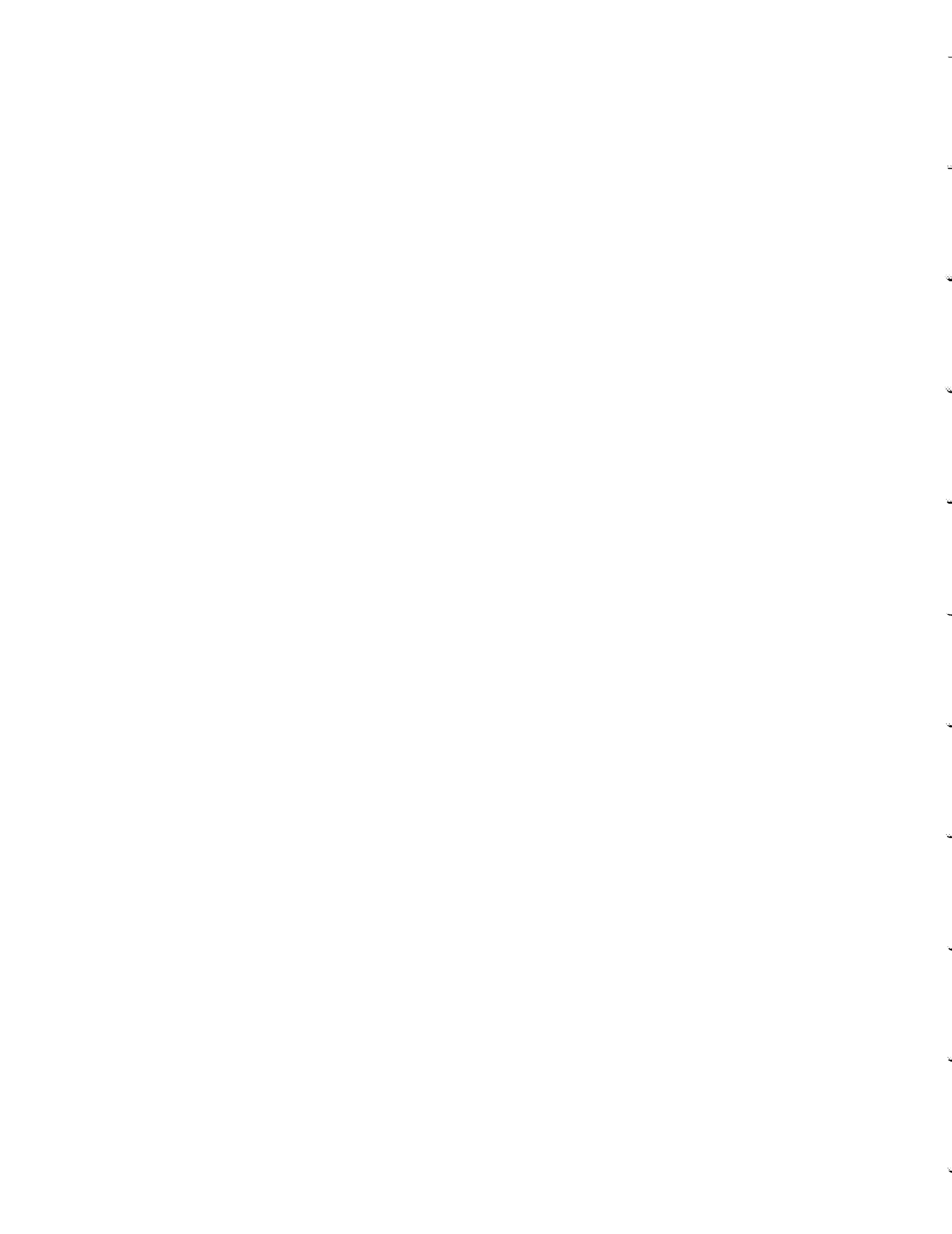



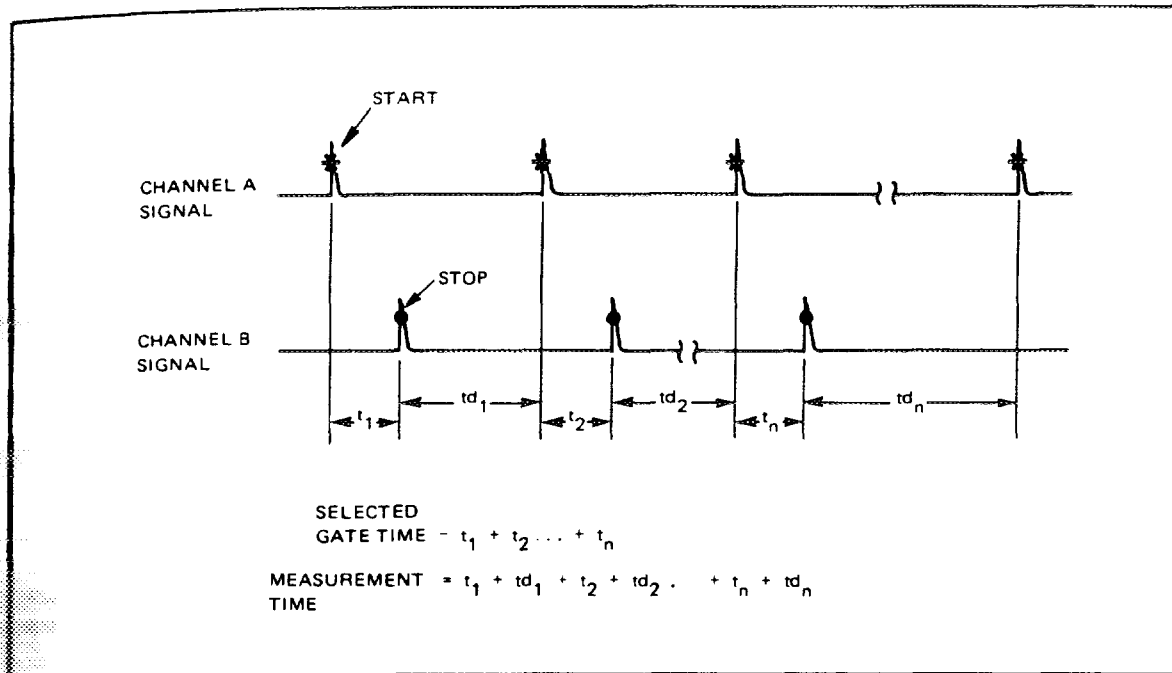

Figure 3-1. Measurement Time for Time Interval Average

3-23. If the time interval used in the equation is unknown, it can be obtained from the counter by selecting MIN. The number of time intervals per second can be taken from an oscilloscope reading. For most purposes, these figures need be only approximate to give a reasonable indication of the waiting time involved.

### 3-24. Ratio Measurements

3-25. The ratio between two frequencies (FB/FA) is measured by connecting one signal to Channel A and the other to Channel B. Both channels operate in the 50  $\mu$ Hz to 500 MHz range. If the higher frequency is connected to Channel B, the ratio will be greater than one. The answer for a ratio measurement is a unitless figure.

3-26. MEASUREMENT TIME. The difference between the selected gate time and the total measurement time depends on the frequency applied to Channel B. In the Ratio mode, the Channel B signal substitutes for the internal 500 MHz time base.

3-27. With the GATE TIME switch set to 1 s, for example,  $5 \times 10^8$  time base counts are needed to end the measurement. When the 500 MHz internal time base is used, the  $5 \times 10^8$  counts are accumulated in 1 second. If, for example, 70 MHz were applied to Channel B and used as the time base, it would take about 7 times as long (7.14 seconds), to accumulate the  $5 \times 10^8$  counts needed to disarm the gate.

3-28. To estimate the measurement time, use the equation below.

$$\text{Measurement Time} = \frac{5 \times 10^8 \text{ Hz}}{\text{Channel B Freq.}} \times \text{Gate Time}$$

$$\text{Example: } \frac{5 \times 10^8 \text{ Hz}}{25 \text{ MHz}} \times 1 \text{ ms} = \frac{5 \times 10^8}{2.5 \times 10^7} \times 1 \times 10^{-3} \text{ sec} = 20 \text{ ms}$$

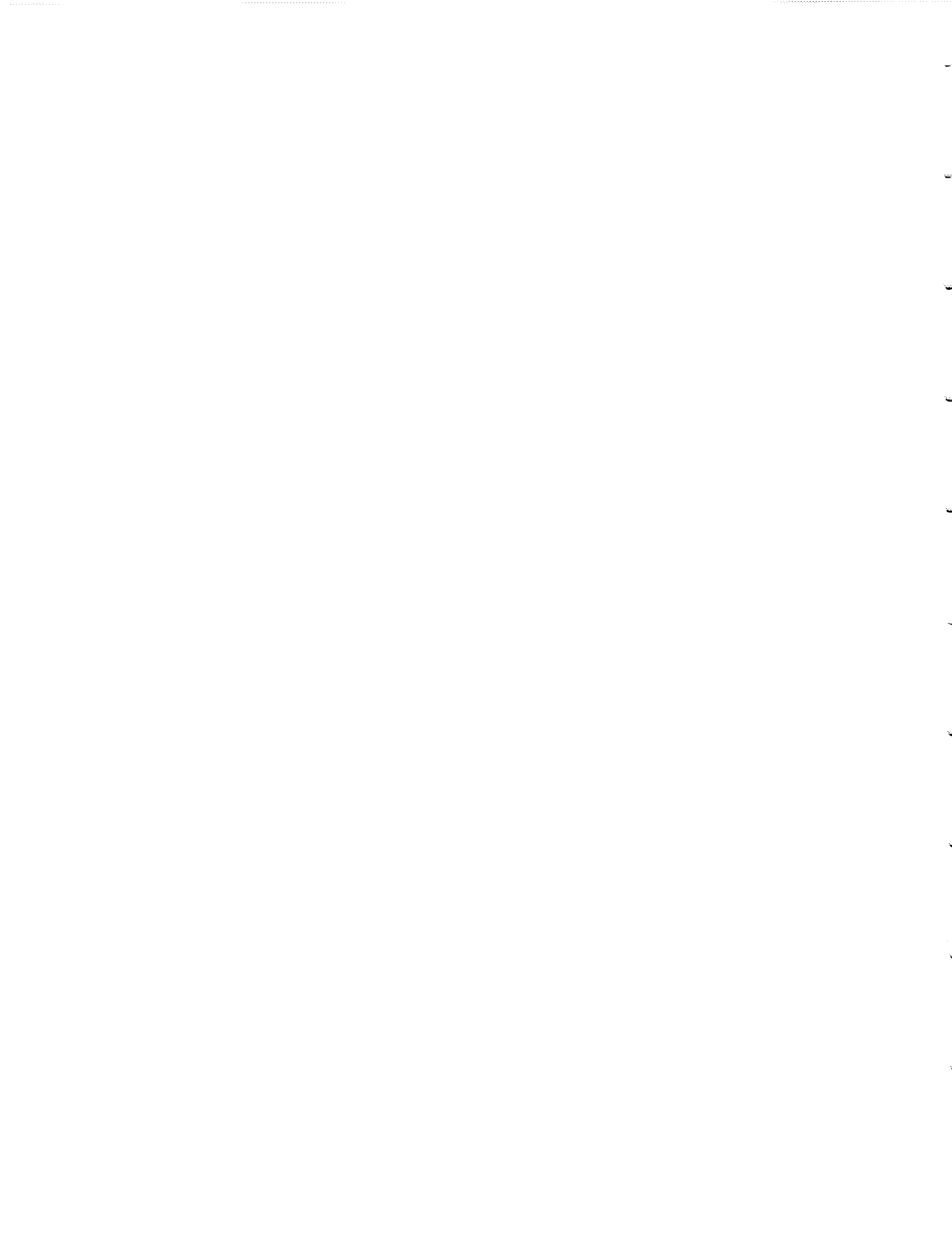

**3-29. Totalize Mode**

3-30. The START and STOP positions on the FUNCTION switch allow manual opening and closing of the counter's main gate. The Input Amplifier Control switch must be placed in SEP. When the switch is in the START position, the counter totalizes the number of times the input signal passes through the Channel A trigger point. The GATE TIME switch does not affect the displayed result in any way.

3-31. BOTH CHANNELS TOTALIZED. When the Input Amplifier Control switch is set to SEP, Channel A and Channel B signals can be totalized simultaneously. The displayed result is a function of the ACCUM MODE START/STOP switch, located on the rear panel. The two signals are added (A+B) or subtracted (A-B), depending on the switch position. When the Input Amplifier Control switch is set to CHECK, the counter always selects A+B.

3-32. A minus sign on the display indicates that during a subtraction (A-B) the B events have outnumbered the A events. With the switch in A-B, the instrument functions like an up-down or reversible counter. That is, the counter will count down from a previously-given positive number. As an example of this, assume that the A frequency is greater than the B frequency and the switch is in A-B. The display accumulates positive numbers at a rate equal to the difference between the two input frequencies. If the frequency of B now becomes greater than A, the displayed count will decrease towards zero, again, at a rate equal to the difference between the two frequencies. Once the declining number passes through zero, the minus sign lights and the display continues to accumulate.

3-33. SCALED OUTPUT. With the FUNCTION switch set to START and SAMPLE RATE to HOLD, the counter scales (divides) the Channel A input frequency by powers of 10. This scaled signal is available on the rear-panel CHAN A SCALER OUTPUT jack. Although the display is not functioning, the counter is accumulating. The GATE TIME switch controls the division factor, as shown in Table 3-1.

**Table 3-1. Scaler Output for Channel A**

GATE TIME SETTING	SCALING FACTOR	SCALED OUTPUT (100 MHz IN OR CHECK)
100 ns	$10^2$	1 MHz
1 $\mu$ s	$10^3$	100 kHz
10 $\mu$ s	$10^4$	10 kHz
100 $\mu$ s	$10^5$	1 kHz
1 ms	$10^6$	100 Hz
10 ms	$10^7$	10 Hz
100 ms	$10^8$	1 Hz
1 s	$10^9$	100 mHz
10 s	$10^{10}$	10 mHz
100 s	$10^{11}$	1 mHz
1000 s	$10^{12}$	100 $\mu$ Hz

**3-34. INPUT TRIGGERING**

3-35. The input circuits provide triggering over a range of -1.3V to +1.3V. The point at which triggering occurs is adjustable with the front-panel LEVEL control. Each input channel has a small amount of hysteresis (about 10 mV). If the SLOPE switch is set to "+," the trigger pulse occurs at the top of the hysteresis window. If the SLOPE switch is set to "-", the pulse occurs on the bottom line of the window. In other words, the signal must pass through the entire hysteresis window before a trigger pulse is generated (see Figure 3-2). The LEVEL control must be placed to allow at least a 1 ns pulse width for the Schmitt Trigger.

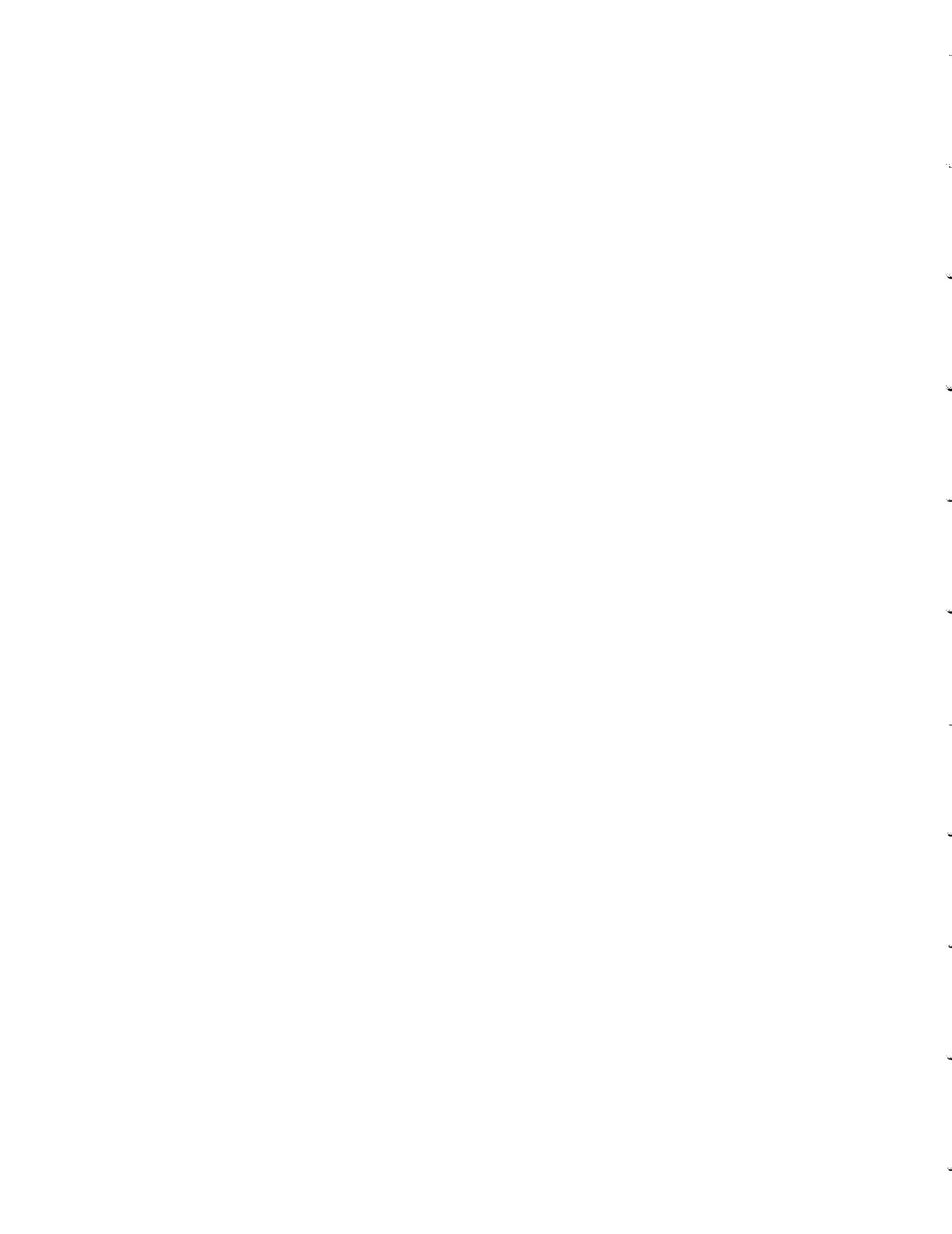

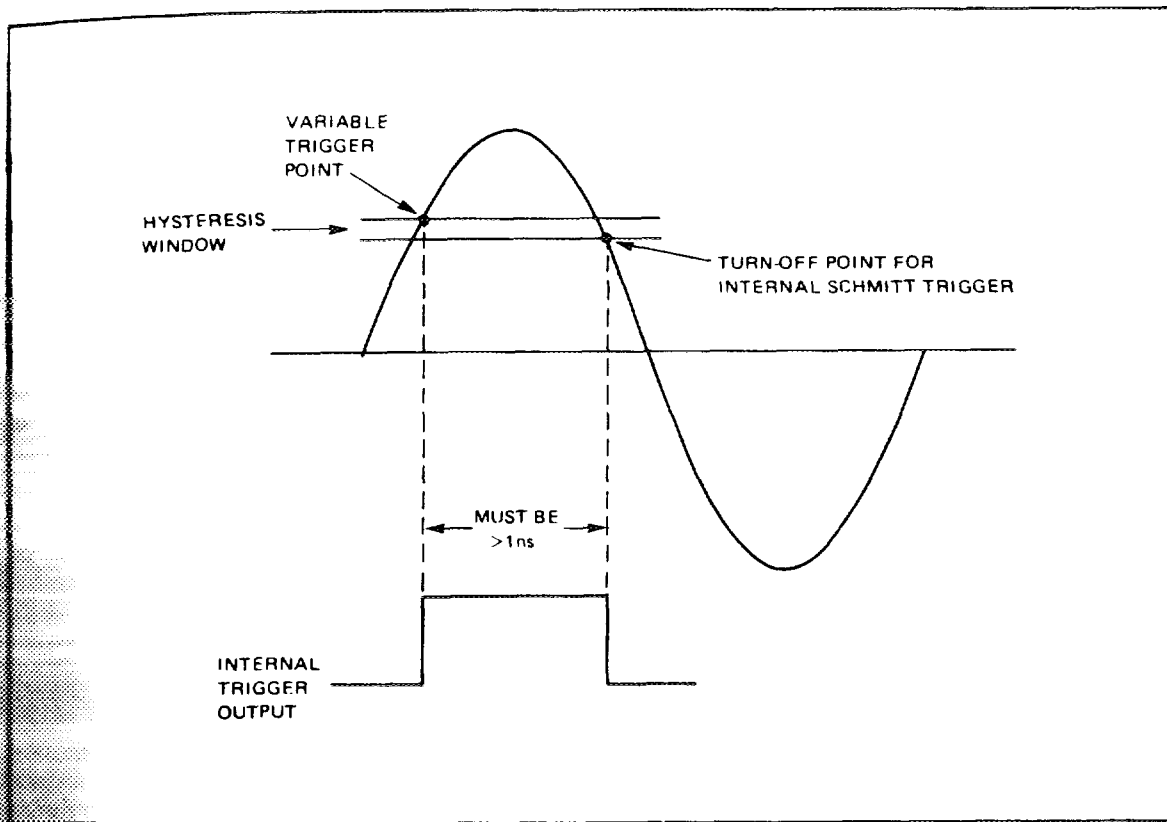

Figure 3-2. Internal Triggering

**3-20. EXCESSIVE GATE TIME**

3-27. In every measurement involving a gate time, the counter depends on the input signal to terminate the measurement. The measurement concludes one clock pulse after the next input pulse following the end of the gate time, not with the gate time itself. If the period of the input signal is much longer than the gate time or if the signal is interrupted sometime during the gate time, the excessive gate time circuits prevent the counter from waiting indefinitely for the terminating pulse. The counter will wait for about 3.5 times the selected gate time before resetting. At the end of excessive gate time, the display will flash instantaneously to lamp test before displaying all zeros. Excessive gate time is especially useful during the time interval measurement; see paragraph 3-20 for a further description.

**3-21. EXTERNAL ARMING AND GATING**

3-28. The GATE CONTROL INPUT jack (rear panel) allows the counter to be externally armed and gated. The jack works in conjunction with the Gate Control switch, located directly below the jack.

**3-29. External Arming**

3-41. When externally arming, set the Gate Control switch to EXT ARM and the SAMPLE RATE switch to HOLD. The counter will ARM when the instrument is first turned on because of the internal arming of the sample rate circuits. After the first measurement, however, the counter's arming circuits are fully controlled by the external source. The counter is armed within 1  $\mu$ s of receiving the arm pulse (500 ns to dc at -1V). Once the counter is armed, the measurement begins with the first Channel A trigger pulse. The counter makes only one measurement for each arm pulse.



### 3-42. External Gating

3-43. When the Gate Control switch is set to EXT GATE, the counter's arming and gating is under full external control. The gating can be accomplished in two ways: single gating or multiple gating.

3-44. SINGLE PULSE GATING. Single gating is accomplished with a single, external gate pulse. The width of this pulse can be varied from 20 ns to 20,000 seconds. When using a single gate, set the GATE TIME switch to MIN. This assures the measurement will always take place during a single, external gate pulse. This will not be true for other settings of the GATE TIME switch.

3-45. MULTIPLE PULSE GATING. This method requires an arming pulse, which is automatically taken from the external gate pulse train. When the GATE TIME switch is in any position other than MIN, the counter accumulates as many external gate pulses as are needed to equal or exceed the gate time selected by the switch. As an example, assume a GATE TIME setting of 10 ms and external gate pulses of 4 ms. The counter requires three of these pulses before a measurement can be completed. The total gate time is 12 ms.

3-46. One of the uses of multiple gating is *frequency averaging*, i.e., an average of frequency measured over multiple bursts. Using the same values as above, Figure 3-3 shows the type of gating in frequency averaging.

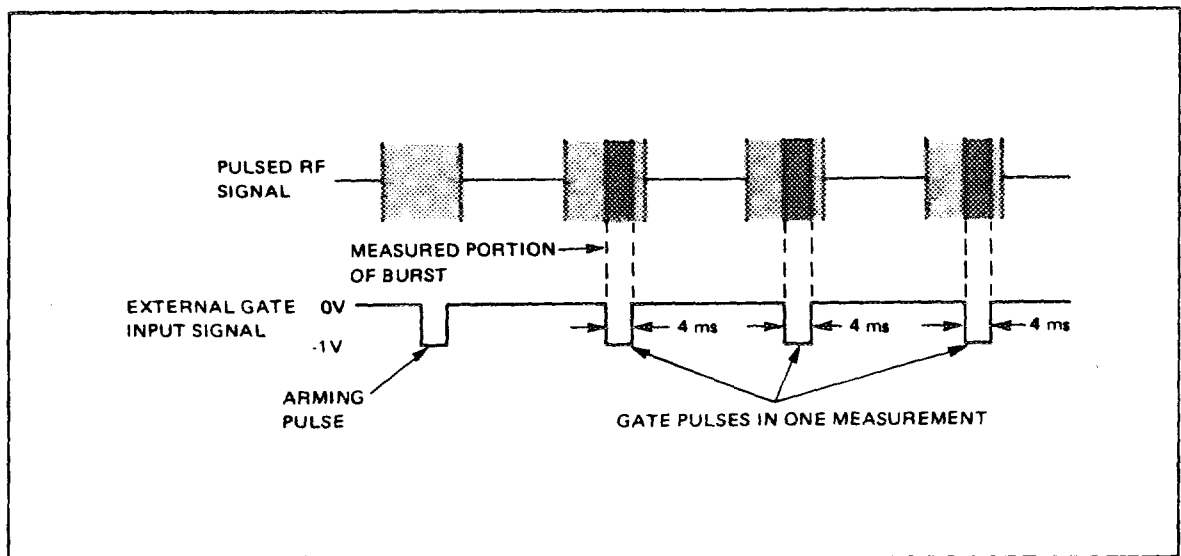
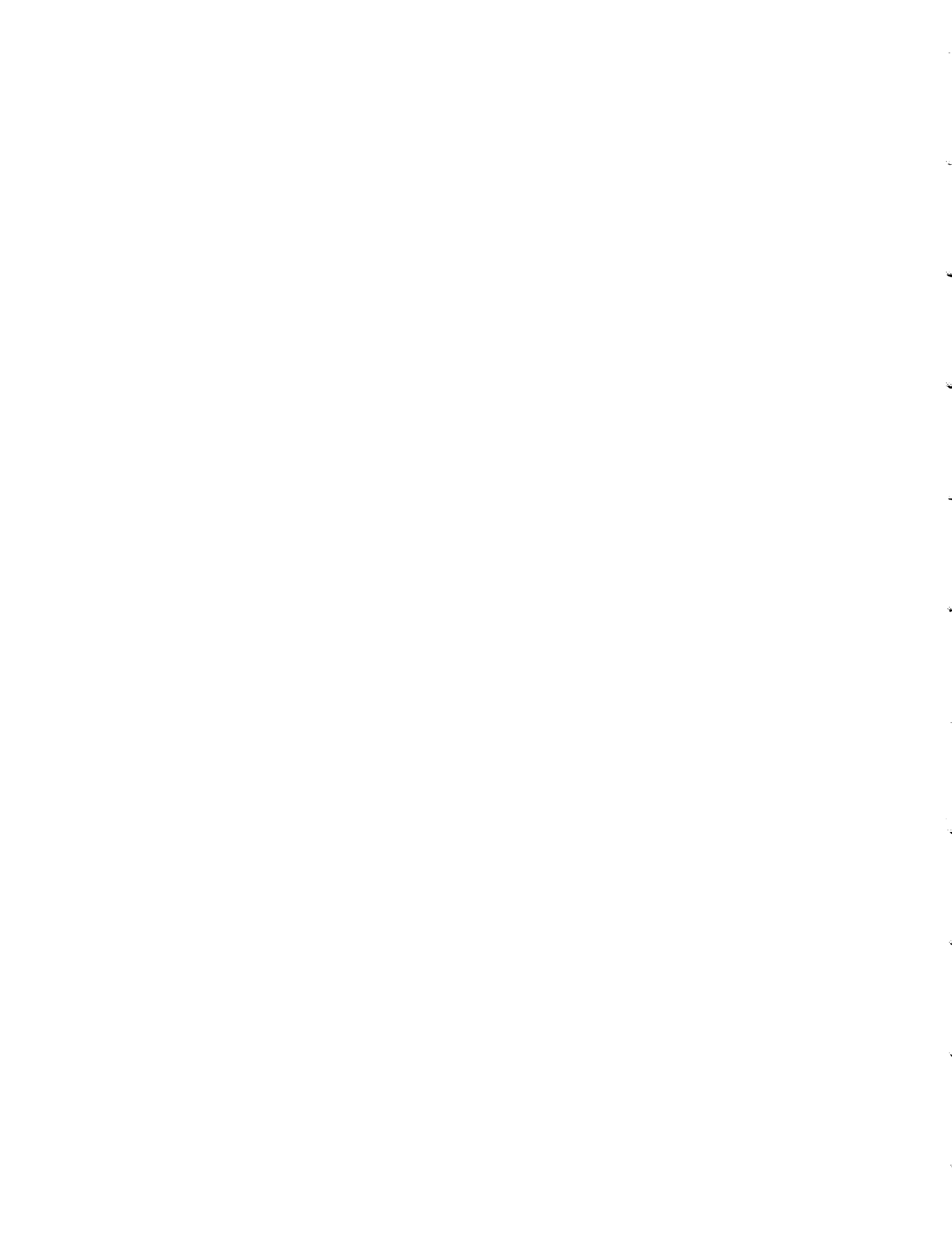

Figure 3-3. Multiple Gating

### 3-47. Time Interval Measurements

3-48. External gating is valuable when measuring the time between two events while ignoring the events occurring between them. The external gate signal must go low (-1 V) before the start pulse and return high (0 V) before the stop pulse.

3-49. SINGLE TIME INTERVALS. As previously mentioned for external gating, a measurement using a single external gate requires the GATE TIME switch to be set to MIN. The counter arms automatically and the external gate pulse provides a control over the time interval measurement. Varying the width of the pulse determines which time interval is measured, as can be seen in Figure 3-4.





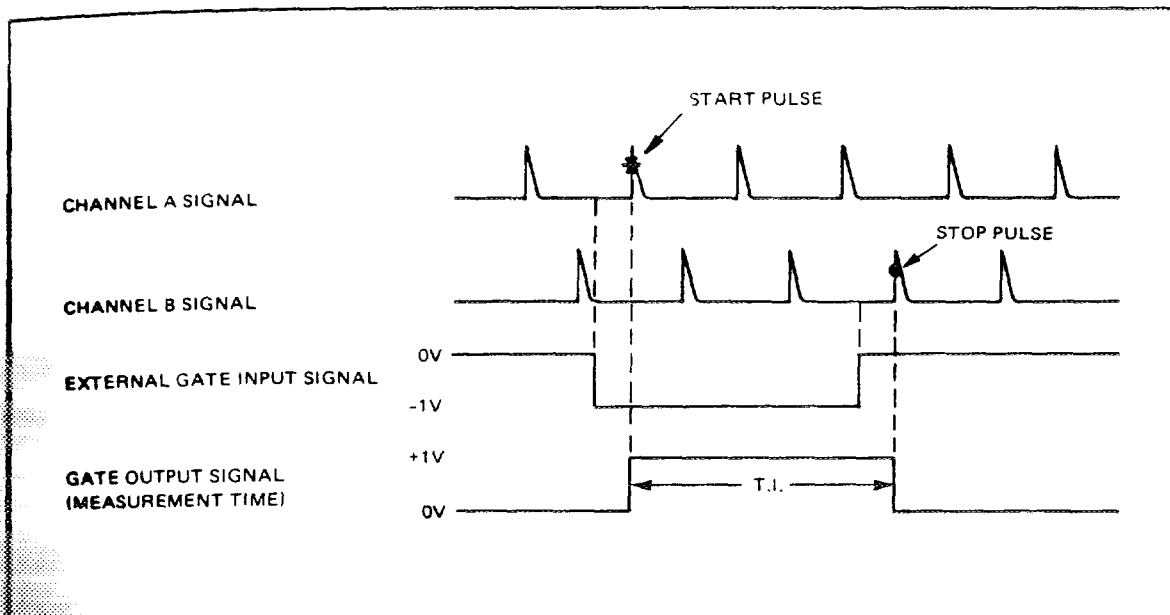
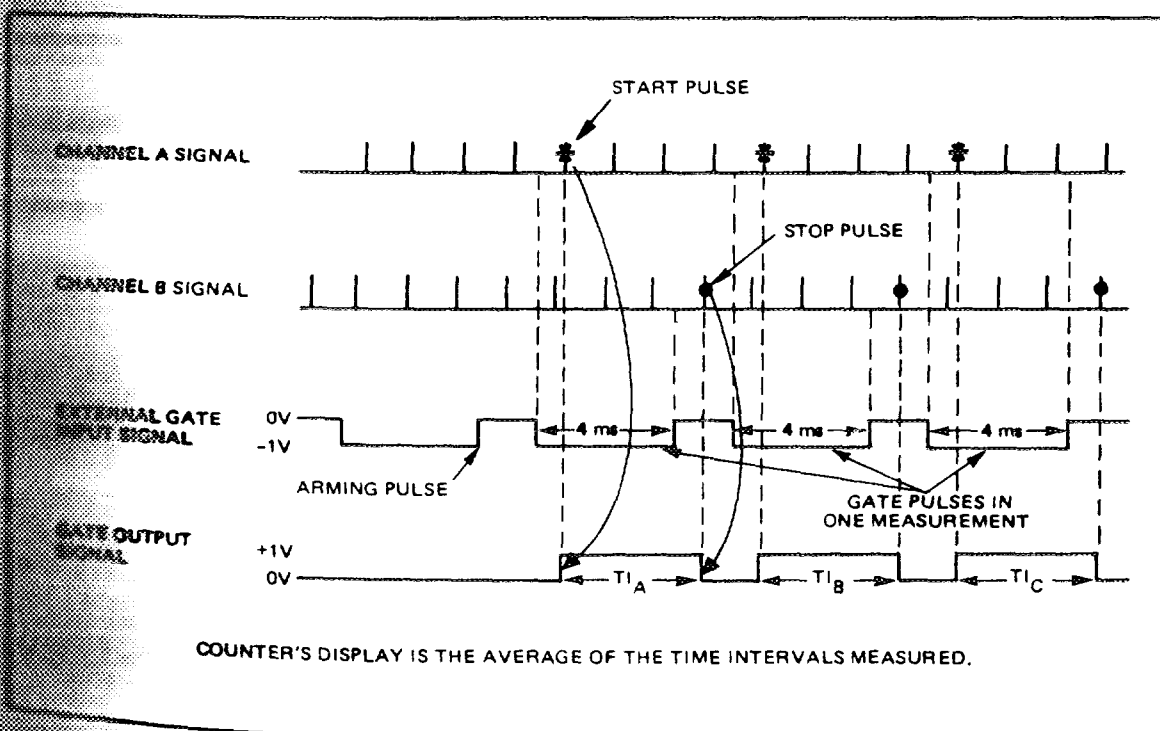

Figure 3-4. External Gating for Single Time Interval

**3-50. MULTIPLE TIME INTERVALS.** An average of time intervals can be measured using the external gating method. This method, as in single time intervals, allows certain pulses of the waveform to be ignored. The GATE TIME switch must be set to any other position than MIN. See Figure 3-5 for an example of time interval averaging. This method does require an arming pulse for each measurement cycle.



COUNTER'S DISPLAY IS THE AVERAGE OF THE TIME INTERVALS MEASURED.

Figure 3-5. External Gating for Time Interval Averaging

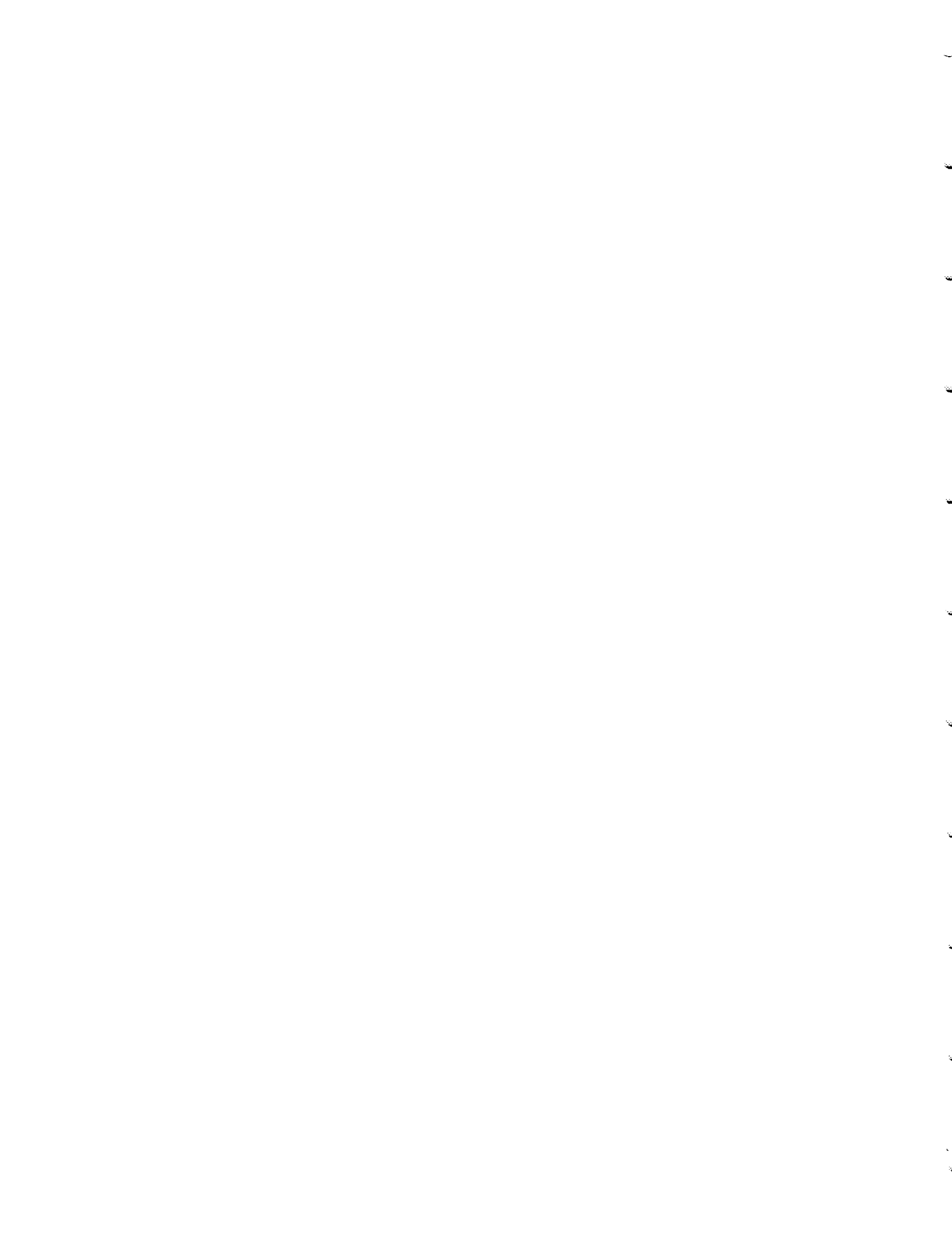

### 3-51. DISPLAY

3-52. The counter uses a 12-digit display: 11 digits of data and 1-digit for the minus sign. Unlike most counters, the number of digits displayed in a measurement is not a function of the input frequency and is not related to the FUNCTION switch. The number of digits is constant for each setting of the GATE TIME switch.

### 3-53. Display Position

3-54. When the DISPLAY POSITION switch is set to AUTO, the counter automatically positions the display's least-significant digit in the right-most column. Rotating the switch to each of its counterclockwise positions (blue dots) shifts the decimal point, hence the display, one place to the left. Once the switch is placed to any position other than AUTO, the annunciator (k, M, n, etc.) stays fixed, regardless of changing input frequency. The annunciator remains fixed until the RESET button is pushed or the FUNCTION switch setting is changed. Manually fixing the decimal point and the annunciator is convenient when collecting measurement data with a digital-to-analog converter. As an example, the DAC can continually record any 3 digits in a possible display of 11, regardless of changing input data.

### 3-55. Asterisk

3-56. The asterisk lamp will light under any one of four conditions: overflow, underflow, factitious zeros, or insufficient oven temperature (standard only). Overflow occurs when the placement of the DISPLAY POSITION switch has positioned the display's most-significant digit(s) so far to the left that it is out of viewable range. Underflow occurs when the placement of the DISPLAY POSITION switch has positioned the display's least-significant digit(s) so far to the right that it is out of viewable range. If the counter is equipped with an oven-controlled oscillator (optional), the operating temperature of the oven must remain constant for the crystal to perform properly. Should the oven temperature drop below its normal operating range, the asterisk light will come on as an indication of this condition.

3-57. *Factitious* zeros occur when the settings of the GATE TIME switch and DISPLAY POSITION switch have been combined to give fewer significant digits than the DISPLAY POSITION demanded. In this combination, the display attempts to blank one or more of the significant digits located to left of decimal point. Instead of blanking the digit, the display substitutes an artificial and meaningless zero to keep that portion of the display filled.

3-58. Although the presence of factitious zeros is a rare occurrence, its appearance can be demonstrated with the counter set up as follows: FUNCTION to **FREQ A**, connect input signal of 125 MHz, turn DISPLAY POSITION switch out of AUTO to about mid-range, turn GATE TIME switch ccw until the display is 125 MHz. The next switch position changes the display to 120 MHz and lights the asterisk. The zero now displayed is a factitious or filler zero.

### 3-59. Arm Light

3-60. An illuminated ARM light indicates that Channel A is not triggering. The condition of this indicator should be observed when adjusting the front-panel controls for a first-time measurement. Insufficient amplitude of the input signal or improper setting of the input controls (LEVEL, ATTEN, etc.) are common causes for the failure of the GATE light to turn on.

### 3-61. Gate Light

3-62. Once Channel A triggers, the ARM light turns off and the GATE light turns on. The GATE indicator lights during the time the counter's event gate is open. For short-duration gate times, the GATE light circuits include a 40 ms one-shot MV to allow a visible flash of the light. The SAMPLE RATE control sets the time between flashes (or measurement cycles).

### 3-63. Lamp Test

3-64. To ensure that all segments of the display are capable of lighting, the counter provides a lamp test. The display should appear like the representation shown on the next page (Figure 3-6).



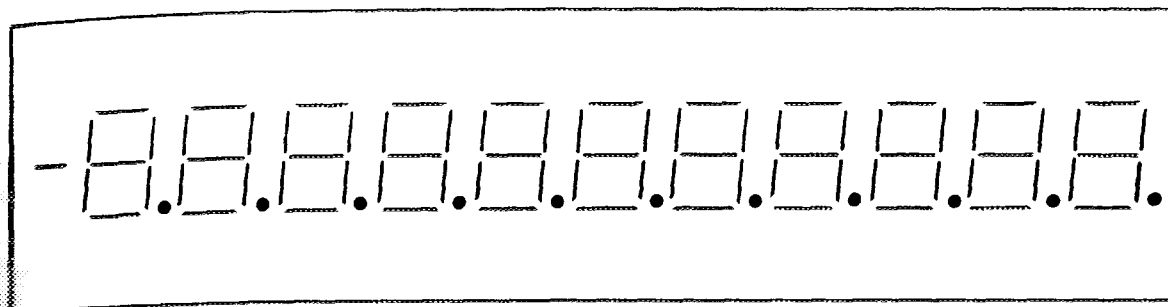

Figure 3-6. Lamp Test

3-65. Lamp test occurs under several conditions:

- a. When the RESET button is pushed.
- b. When the POWER switch is placed to ON, lamp test will light for about 2 seconds.
- c. When switching between detent positions of the GATE TIME switch, FUNCTION switch, or DISPLAY POSITION switch.
- d. When counter is attempting to phase lock the internal oscillator to an external standard.
- e. When the counter has gone into excessive gate time.
- f. When operating with an external frequency standard (rear panel INT STD-EXT STD set to EXT STD) and the external frequency is lost or disconnected.

### 3-66. COOLING

3-67. The counter's fan, located behind the display assembly, provides forced-air cooling to the electronic components throughout the instrument. The fan takes air in through the left side panel and bottom cover and exhausts it through the top cover and right side cover via the plug-in compartment.

#### NOTE

Check for proper air flow each time the instrument is turned on. If the unit is operated for extended periods of time without adequate cooling, the counter will automatically turn off.

### 3-68. AIR FILTER CLEANING

#### NOTE

Instruments with serial number 1708A02576 or higher are supplied less the air filters. Hewlett-Packard recommends removing the filters from all previous units. If desired to retain the filter protection, follow the step-by-step instructions below.

3-69. When the instrument is placed into service, the air filters should be inspected frequently to determine the rate at which they collect dirt in their particular environment. Under average conditions, the air filters should be cleaned about every 3 months. To remove these filters, proceed as follows:

- a. Remove power cord at rear panel.
- b. Remove the top and bottom covers (4 screws each).
- c. Remove the 4 screws holding in display assembly (see Figure 3-7). Remove display assembly from mainframe and disconnect its power cable at bulkhead.
- d. Remove left-front side cover (4 screws).
- e. On left side frame, remove right-most top and bottom screws (1 ea.) and extract side air filter.
- f. Remove the 4 screws holding the 2 internal brackets and extract bottom air filter.

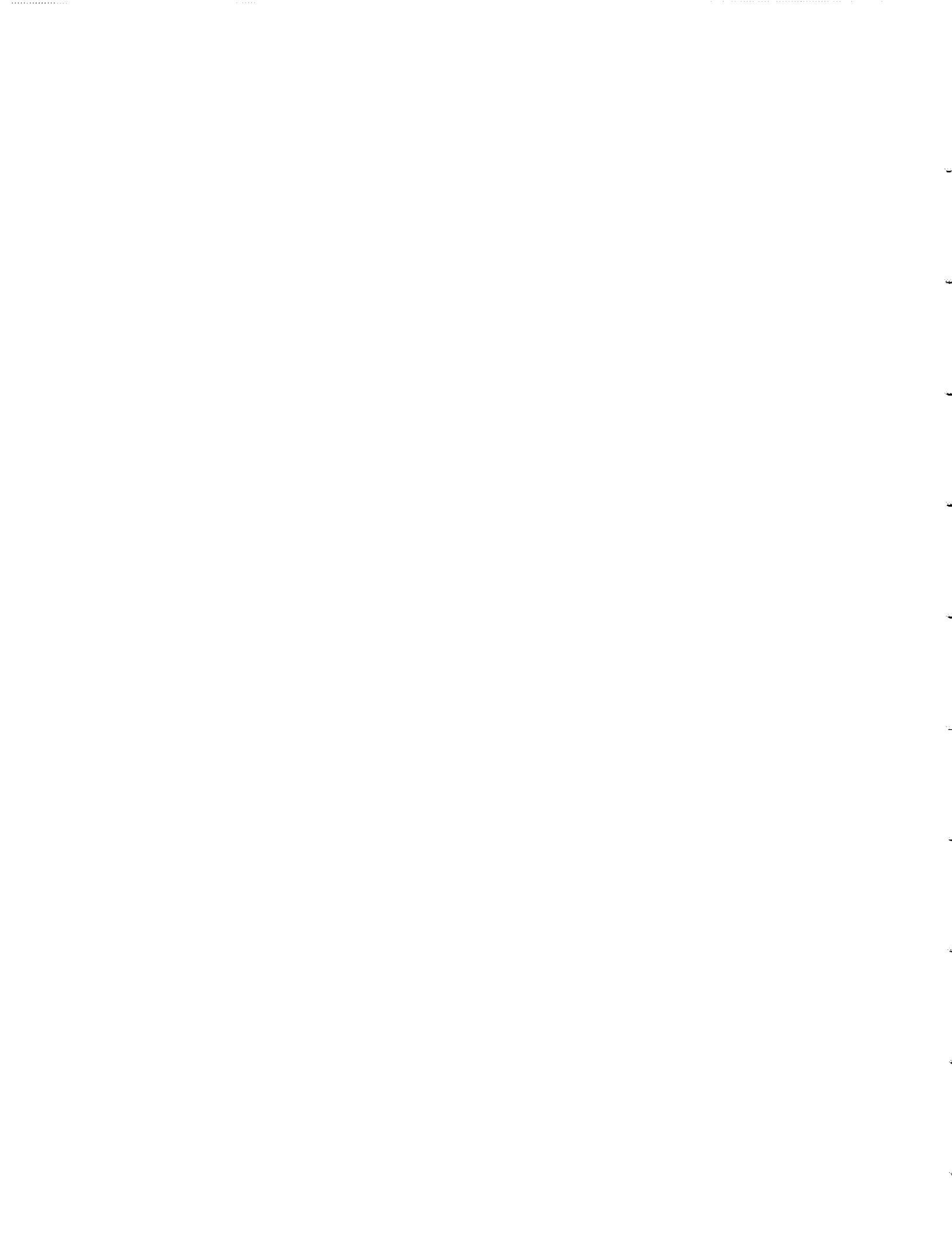

Model 5345A  
Operation

Use the following procedure to clean the air filters.

- a. Wash air filters with water.
- b. Let stand until completely dry.
- c. Recoat filters with *RP Super Filter Coat Adhesive*, Research Products Corporation.

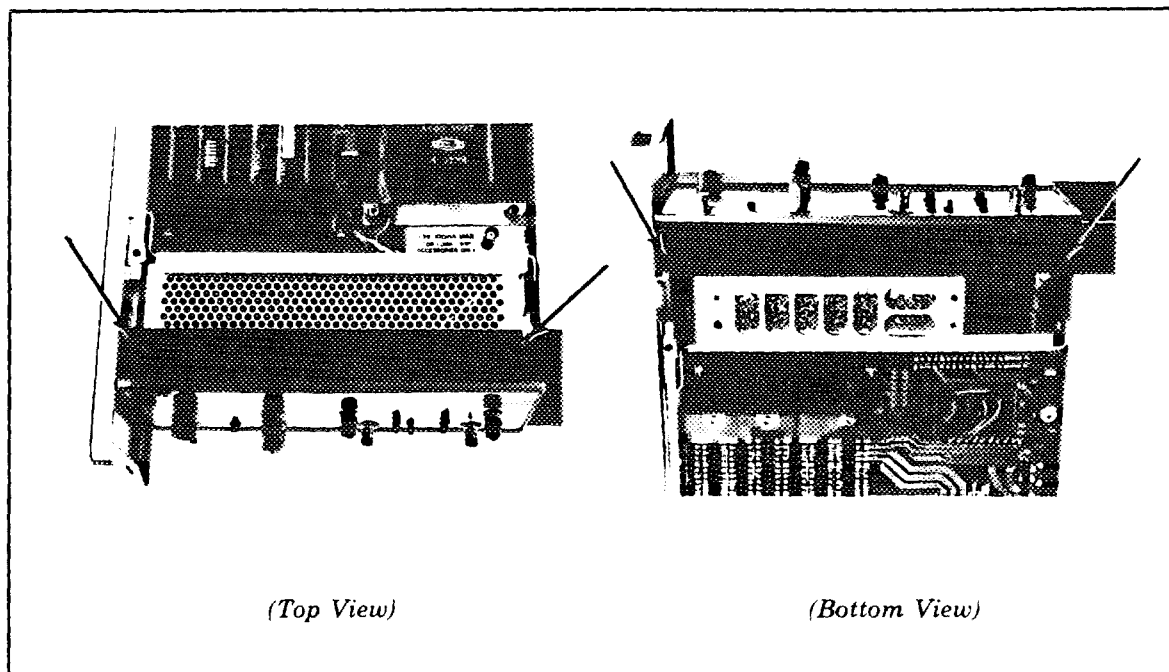

Figure 3-7. Location of Display Assembly Screws

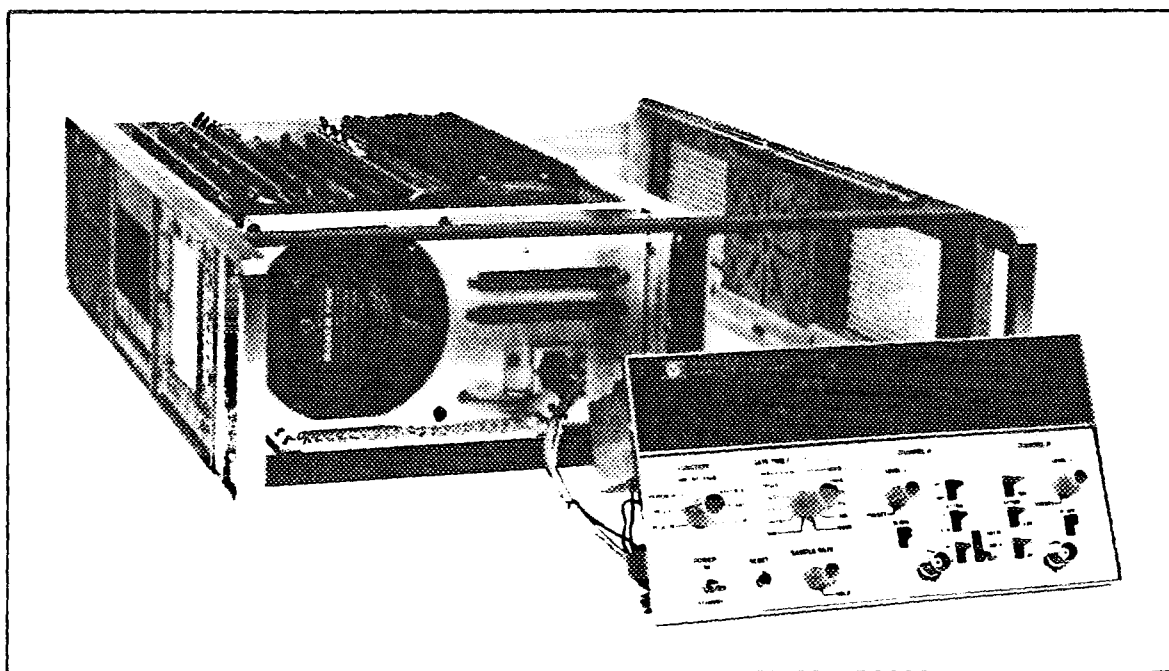
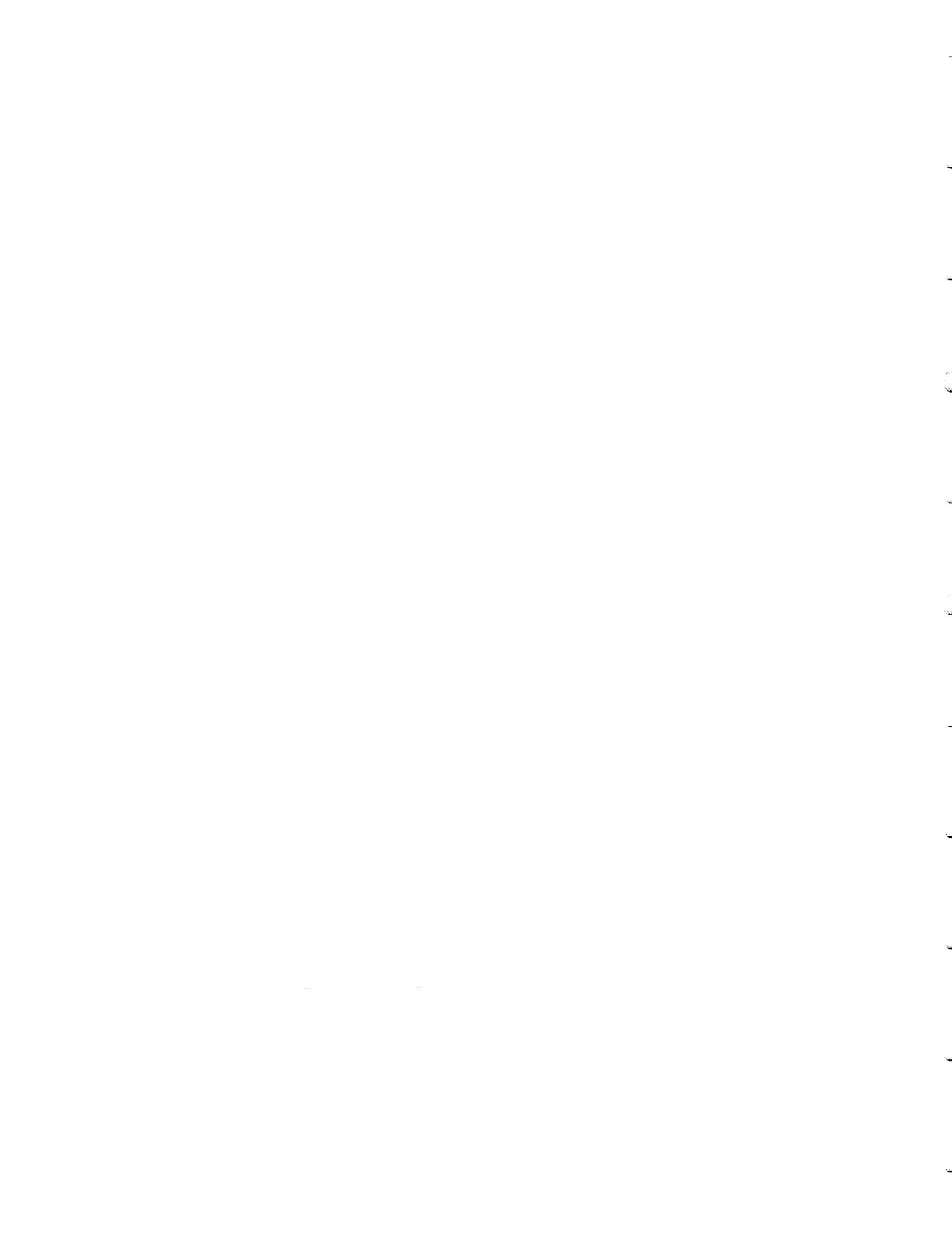

Figure 3-8. Removal of Display Assembly





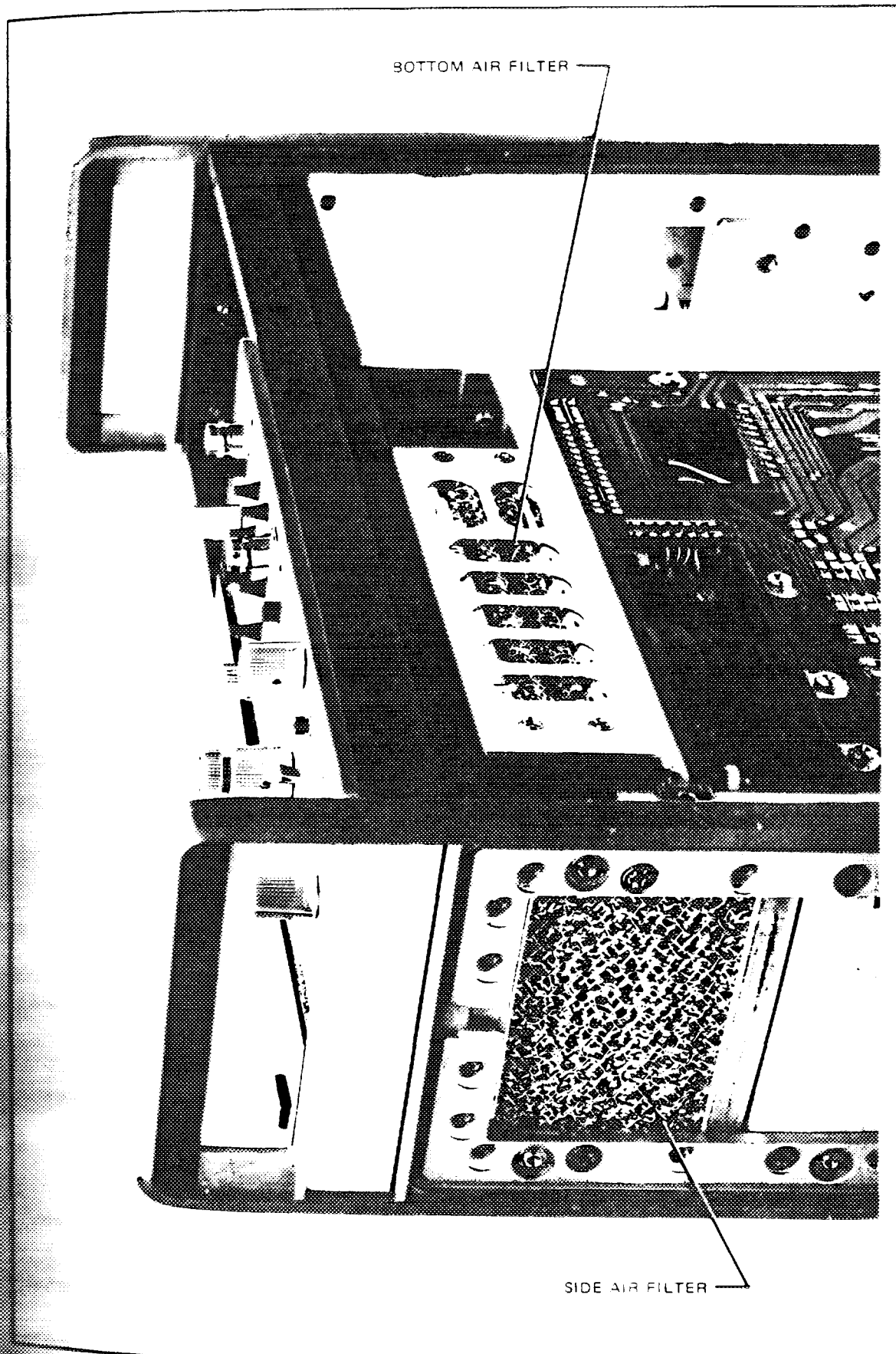
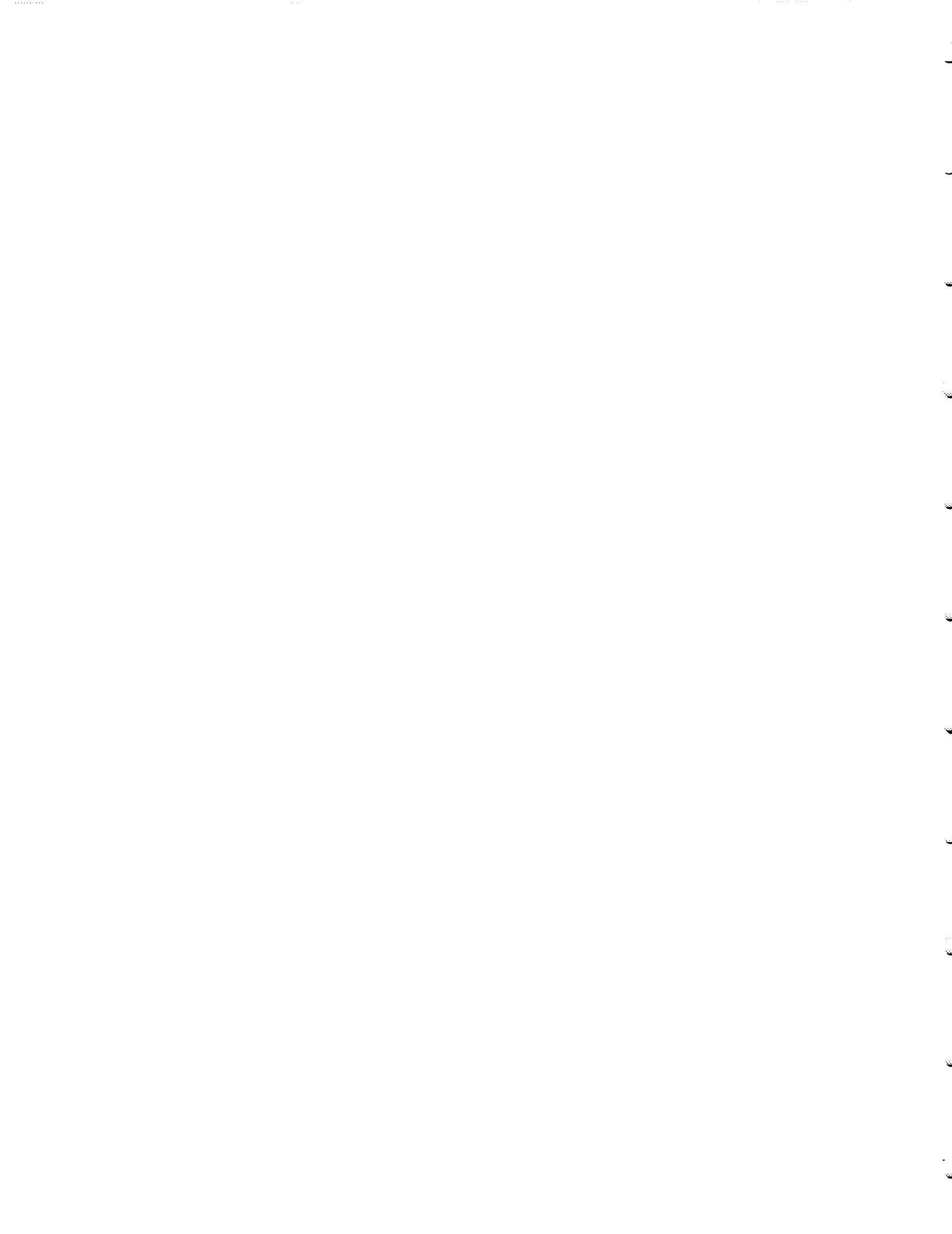
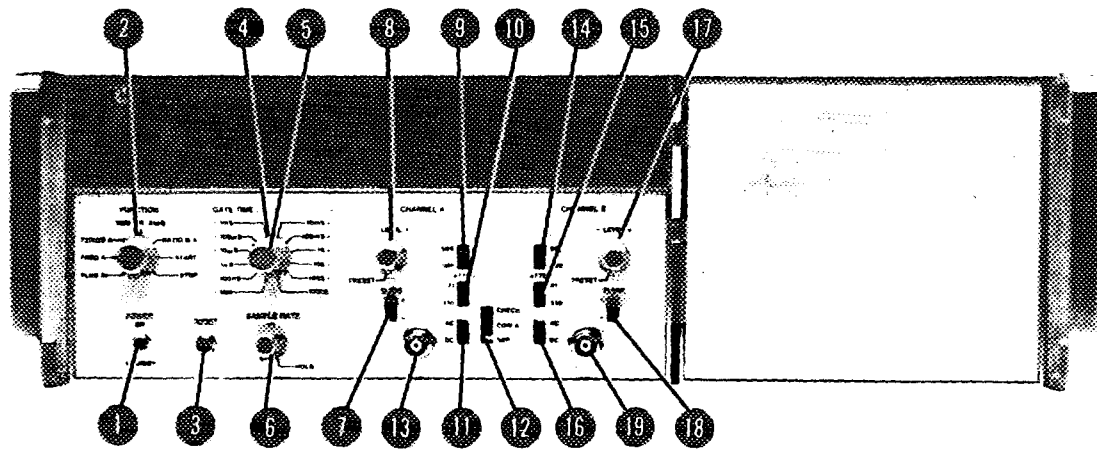

Figure 3-9. Location of Air Filters



Model 5345A  
Operation



1. **POWER** switch ① . In **STANDBY** position, supplies power to oscillator and oven (Option 001) to maintain a constant temperature for the crystal. In **ON** position, supplies normal operating power to remainder of instrument.
2. **FUNCTION** selector ② . Selects mode of operation.
  - a. **PLUG-IN** — Enables plug-in to make measurement.
  - b. **FREQ A** — Sets counter to measure frequency applied to **CHANNEL A** jack.
  - c. **PERIOD A** — Sets counter to measure period or period average of signal applied to **CHANNEL A** jack.
  - d. **TIME INT. A to B** — Sets counter to measure single time interval or time interval average. Channel A starts measurement and Channel B stops measurement.
  - e. **RATIO B/A** — Sets counter to measure the ratio of Channel B frequency to Channel A frequency.
  - f. **START, STOP** — Used for totalize mode to manually open and close counter's main gate and to turn scaled output on and off (**SAMPLE RATE** in **HOLD**).
3. **RESET** button ③ . Resets display and internal count to zero and arms counter for new measurement. Generates lamp test.
4. **GATE TIME** switch ④ . Selects total amount of time that the gate is open. **MIN** position opens main gate for one event or 50 ns, whichever is greater.
5. **DISPLAY POSITION** switch ⑤ (blue knob). In **AUTO**, counter displays least-significant digit in right-most column. Annunciators change with input frequency. Any other position manually fixes decimal point and annunciators.
6. **SAMPLE RATE** control ⑥ . Varies time between measurements from <.1 sec to >5 sec. **HOLD** position holds display indefinitely.
7. **SLOPE** switch ⑦ ⑧ . Permits triggering on positive or negative slope of input signal.

Figure 3-10. Front Panel Controls and Connectors

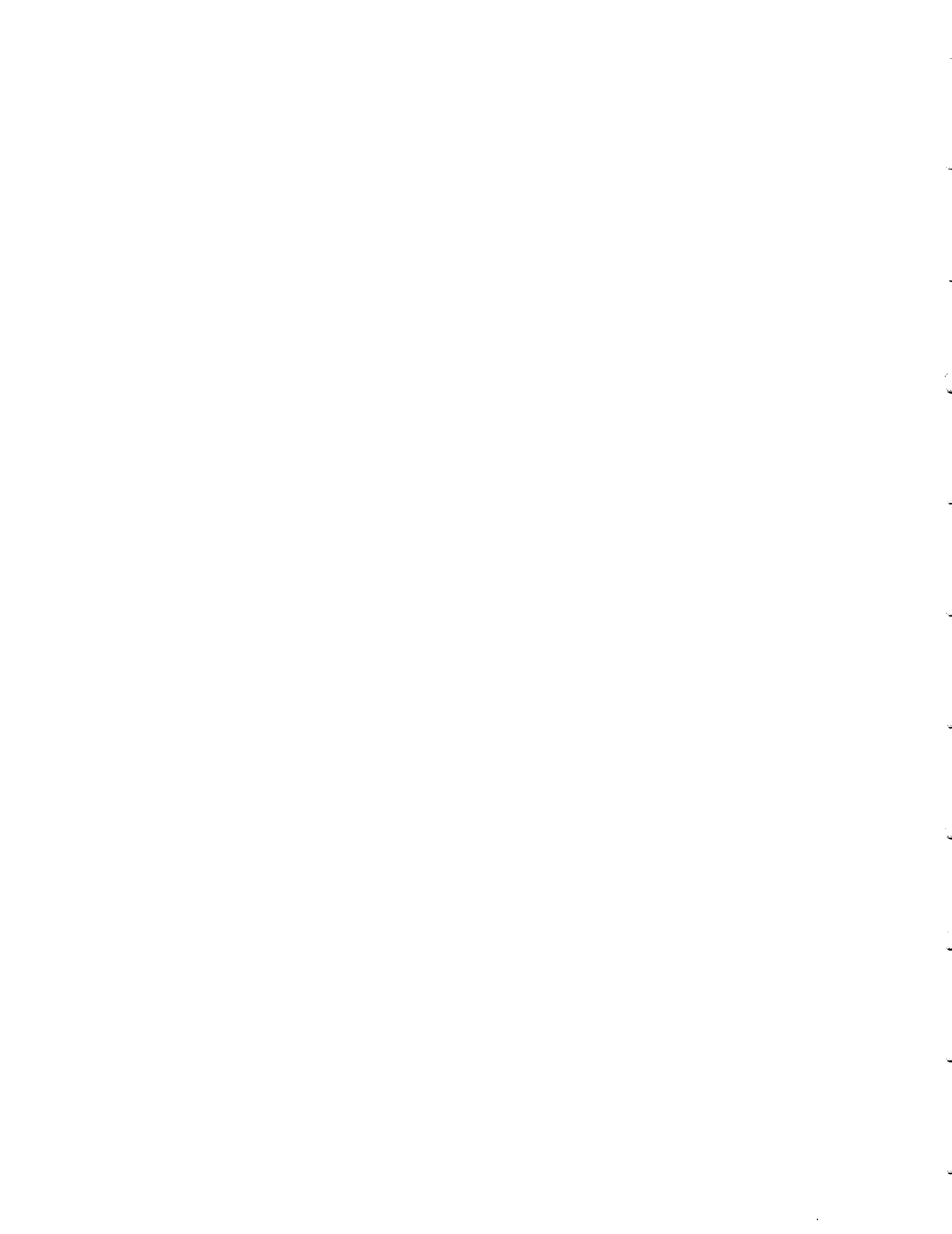

8. LEVEL control ⑧ ⑰ . Used in conjunction with ATTEN switch to select voltage at which triggering occurs. With X1 attenuator setting, level is variable  $\pm 1.3$  V; on X10,  $\pm 13$  V.
9. Input Impedance Switch ⑨ ⑱ . Selects input impedance of  $50\Omega$  or  $1\text{ M}\Omega$  shunted by less than  $30\text{ pF}$ .
10. ATTEN switch ⑩ ⑲ . Selects attenuation for input signal. Used in conjunction with LEVEL control to set trigger point. Input level is not affected in X1 position. Signal amplitude is reduced by factor of 10 in X10 position.
11. Coupling switch ⑪ ⑲ . Selects direct or capacitor coupling for input signal.
12. Input Amplifier Control switch ⑫ .
  - a. CHECK — Checks that counter is functioning properly by connecting internal  $100\text{ MHz}$  test signal to Channels A and B.
  - b. COM A — Operationally connects A and B channels in parallel. Used for single source time interval measurements. Channel B jack is not active. Channel A and B Input Impedance switches must be set to same position.
  - c. SEP — Allows independent operation of Channel A and B.
13. Input jacks ⑬ ⑳ . Inputs for Channel A and Channel B. Each input can accept signals from  $50\ \mu\text{Hz}$  to  $500\text{ MHz}$ .

Figure 3-10. Front Panel Controls and Connectors (Continued)

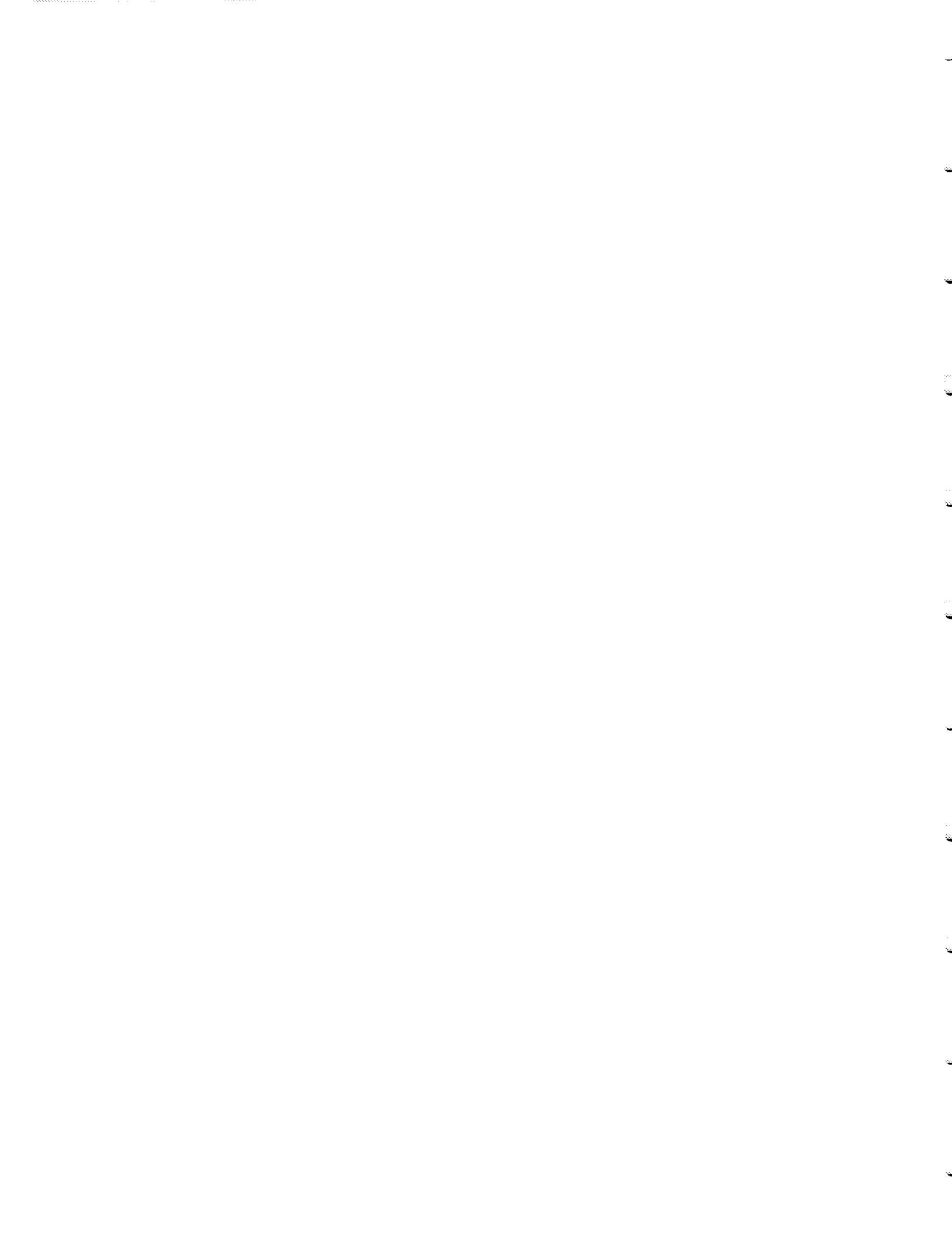

Model 5345A  
Operation

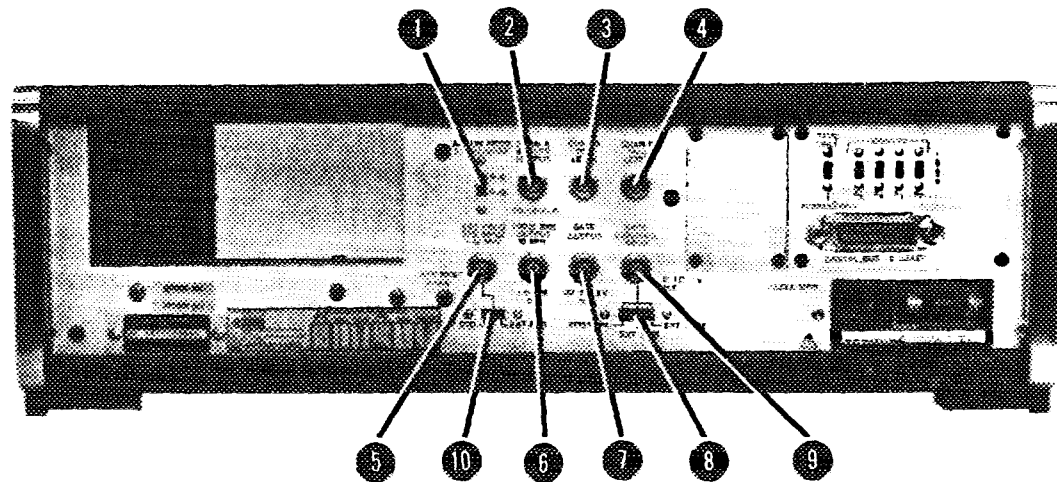

1. ACCUM MODE START/STOP switch ①. Used when totalizing two input signals. In A-B position, Channel B counts are subtracted from Channel A counts. In A+B position, the counts of each channel are added for the total displayed count.
2. CHAN A SCALER OUTPUT jack ②. With the FUNCTION switch set to START and the SAMPLE RATE control in HOLD, jack provides scaled output of Channel A input frequency or internal 100 MHz check signal.
3. CHAN A TRIG LEVEL jack ③. Output level corresponds to trigger point of Channel A. LEVEL control varies output  $\pm 1.3$  Vdc.
4. CHAN B TRIG LEVEL jack ④. Output level corresponds to trigger point of Channel B. LEVEL control varies output  $\pm 1.3$  Vdc.
5. EXT FREQ STD INPUT jack ⑤. Allows internal time base to phase lock to external frequency standard. Possible input frequencies =
 
$$\frac{10 \text{ MHz}}{\text{any Integer from 1 to 10}} = 10 \text{ MHz, } 5 \text{ MHz, } 2.5 \text{ MHz, } 2 \text{ MHz, } 1 \text{ MHz, etc.}$$
6. FREQ STD OUTPUT jack ⑥. Provides 10 MHz internal standard signal for external use. Amplitude is 1 Vrms into 50 $\Omega$ .
7. GATE OUTPUT jack ⑦. Provides output pulses of counter's event gate.
8. GATE CONTROL INPUT jack ⑧. Allows counter's main-gate/arm circuits to be controlled from external source. Works with Gate Control switch. See paragraph 3-38.
9. Gate Control switch ⑨.
  - a. INTERNAL — Allows normal operation of counter.
  - b. EXT ARM — Allows counter to be armed from external source. SAMPLE RATE control must be set to HOLD. Counter will make only one measurement for each arm pulse. Measurement begins with first Channel A pulse after arm pulse.
  - c. EXT GATE — Allows total control of gating circuits (see paragraph 3-42). Used in frequency average and in pulse selection for time interval and time interval average.
10. FREQUENCY STANDARD INT-EXT switch ⑩. Allows an external frequency standard connected to ⑤ EXT FREQ STD INPUT to be used in the counter for the time base. In the INT position, the EXT FREQ STD INPUT connector is not connected through to circuits in the counter.

Figure 3-11. Rear Panel Controls and Connectors

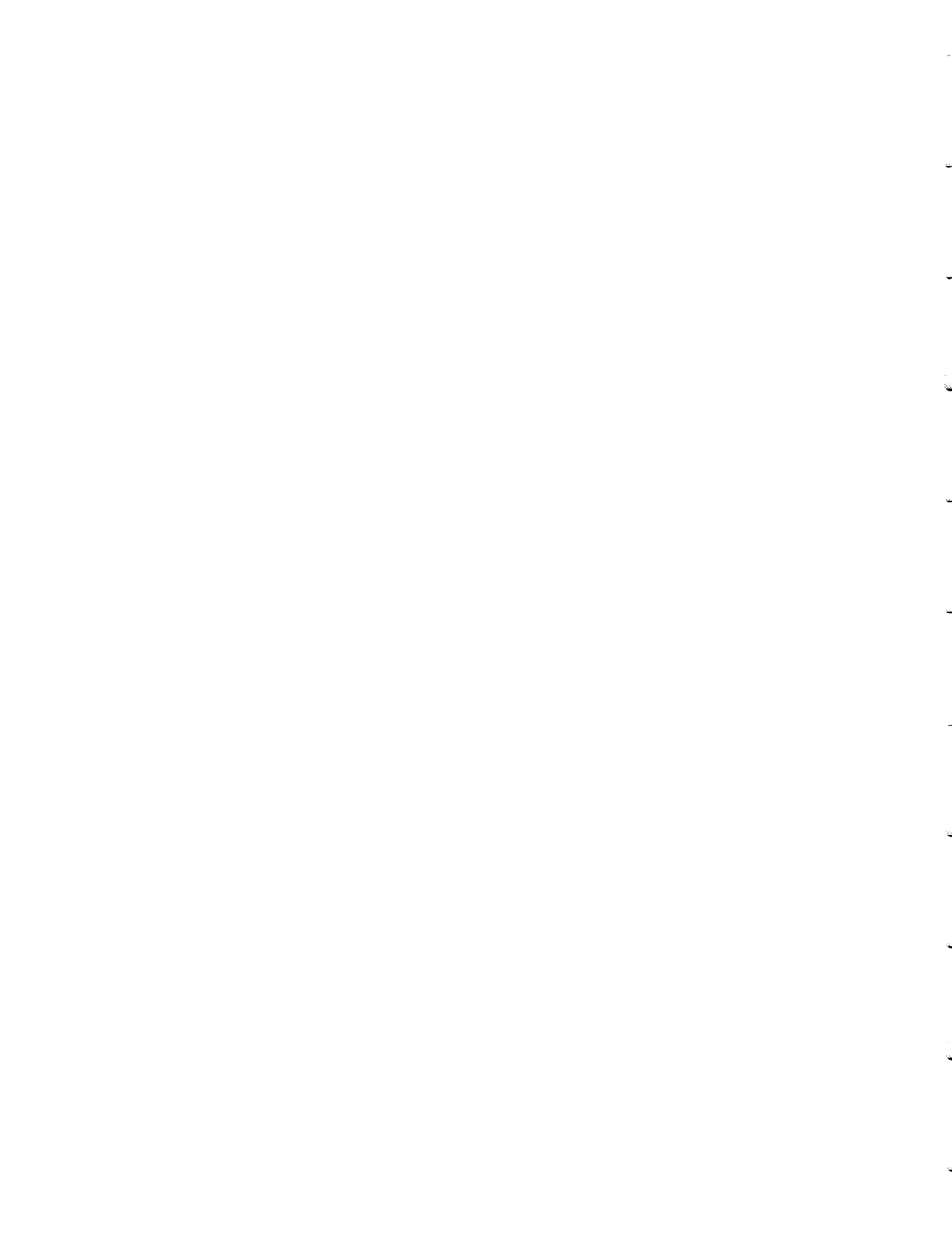



Table 3-2. Self Check

1. Set the counter controls as follows:

Input Amplifier Control switch to CHECK.  
FUNCTION switch to PLUG-IN.  
GATE TIME switch to MIN.  
DISPLAY POSITION switch to AUTO.  
SAMPLE RATE control to maximum ccw.

2. Turn POWER switch to ON. Check that the counter displays a minus sign and eleven 7-segment symbols (  $\mathcal{G}$  ) with 11 decimal points. This display should last about 2 seconds before switching to 11 zeros with no decimal points.
3. Set FUNCTION switch to FREQ A. The GATE light should be flashing.
4. Set GATE TIME switch as shown in table below, and check for proper display.

GATE TIME	DISPLAY	ANNUNCIATOR
MIN	.1	G Hz
100 ns	.10	G Hz
1 $\mu$ s	100.	M Hz
10 $\mu$ s	100.0	M Hz
100 $\mu$ s	100.00	M Hz
1 ms	100.000	M Hz
10 ms	100.0000	M Hz
100 ms	100.00000	M Hz
1 s	100.000000	M Hz
10 s	100.0000000	M Hz
100 s	100.00000000	M Hz
1000 s	00.000000000	M Hz*

5. Set FUNCTION switch to PERIOD A and then to TIME INT. A to B. Check for proper display, as shown in the table below.

GATE TIME	DISPLAY	ANNUNCIATOR
MIN	10.	n sec
100 ns	10.	n sec
1 $\mu$ s	10.0	n sec
10 $\mu$ s	10.00	n sec
100 $\mu$ s	10.000	n sec
1 ms	10.0000	n sec
10 ms	10.00000	n sec
100 ms	10.000000	n sec
1 s	10.0000000	n sec
10 s	10.00000000	n sec
100 s	10.000000000	n sec
1000 s	0.0000000000	n sec*

6. Set FUNCTION switch to RATIO.

7. Set GATE TIME switch as shown in table below, and check for proper display.

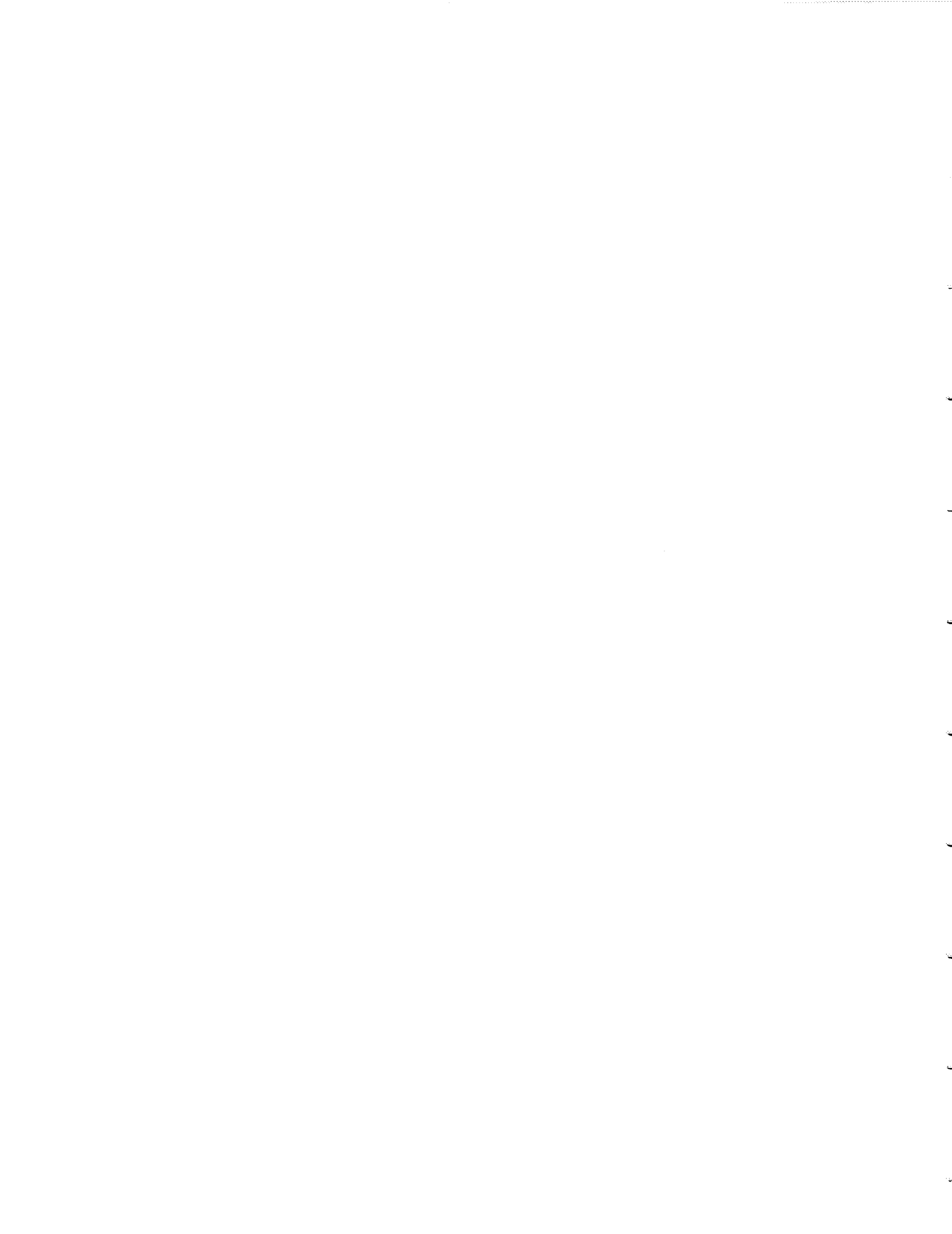



Table 3-2. Self Check (Continued)

GATE TIME	DISPLAY
MIN	1.
100 ns	1.0
1 μs	1.00
10 μs	1.000
100 μs	1.0000
1 ms	1.00000
10 ms	1.000000
100 ms	1.0000000
1 s	1.00000000
10 s	1.000000000
100 s	1.0000000000
1000 s	.00000000000*

8. Set FUNCTION switch to START. Check that counter totalizes and that the GATE light is on.
9. Set FUNCTION switch to STOP. Check that GATE light goes out and the display is held.
10. Set FUNCTION switch to START. The counter should begin totalizing from the previously held number.
11. Set FUNCTION switch to FREQ A and GATE TIME switch to 100 μs. Display is now 100.00 MHz.
12. Turn the DISPLAY POSITION switch (blue knob) through its positions and check for proper display, as shown in the table below.

DISPLAY POSITION	DISPLAY (X = BLANK)	ANNUNCIATOR
AUTO	XXXXXX100.00	M Hz
100 s	XXXXXXXX100.	*M Hz
10 s	XXXXXXXX100.0	*M Hz
1 s	XXXXXX100.00	M Hz
100 ms	XXXXX100.00X	M Hz
10 ms	XXXX100.00XX	M Hz
1 ms	XXX100.00XXX	M Hz
100 μs	XX100.00XXXX	M Hz
10 μs	X100.00XXXXX	M Hz
1 μs	100.00XXXXXX	M Hz
100 ns	00.00XXXXXXX	*M Hz
MIN	0.00XXXXXXXX	*M Hz

13. Push RESET button. Check that counter displays a minus sign and eleven 7-segment symbols (  ) with 11 decimal points.

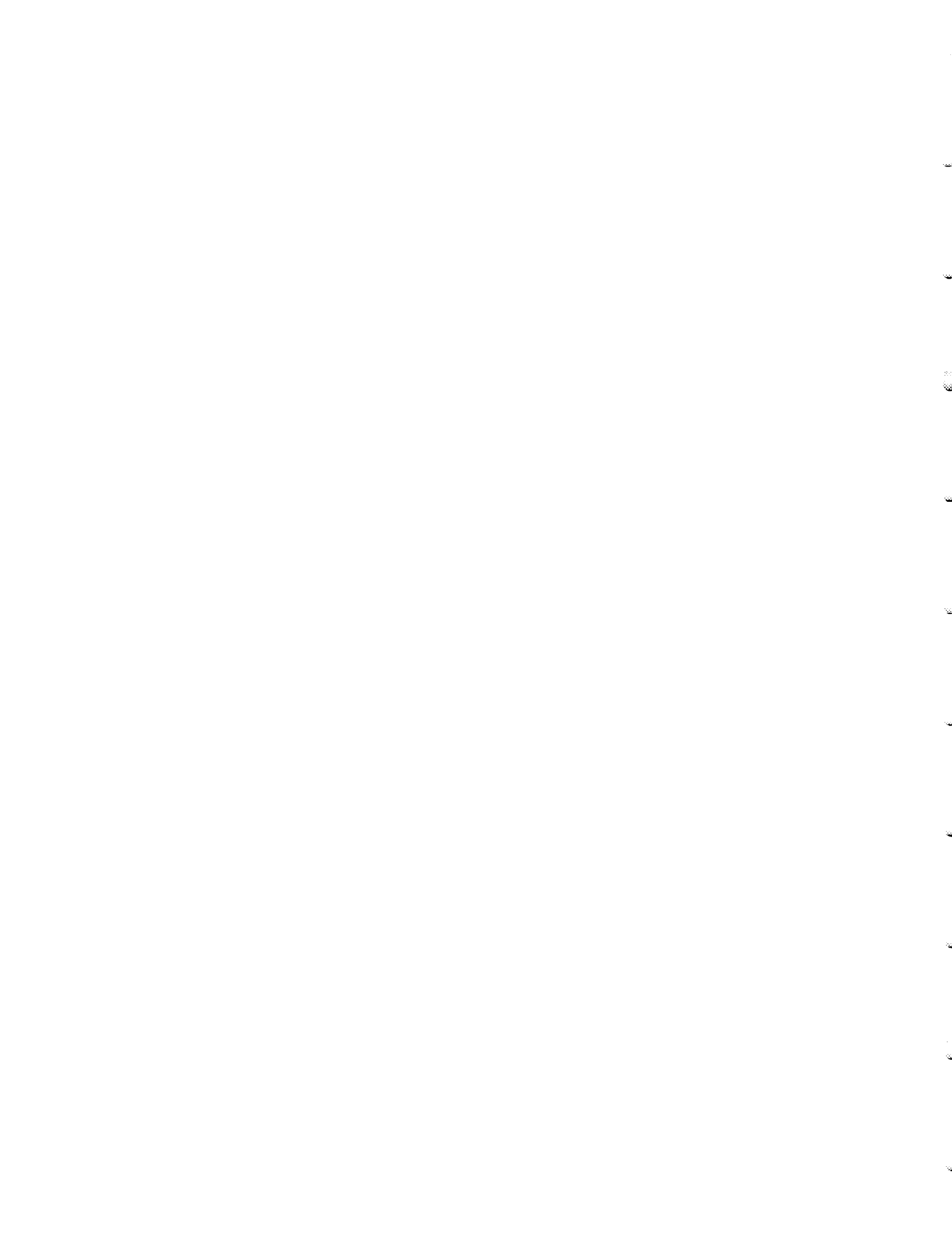

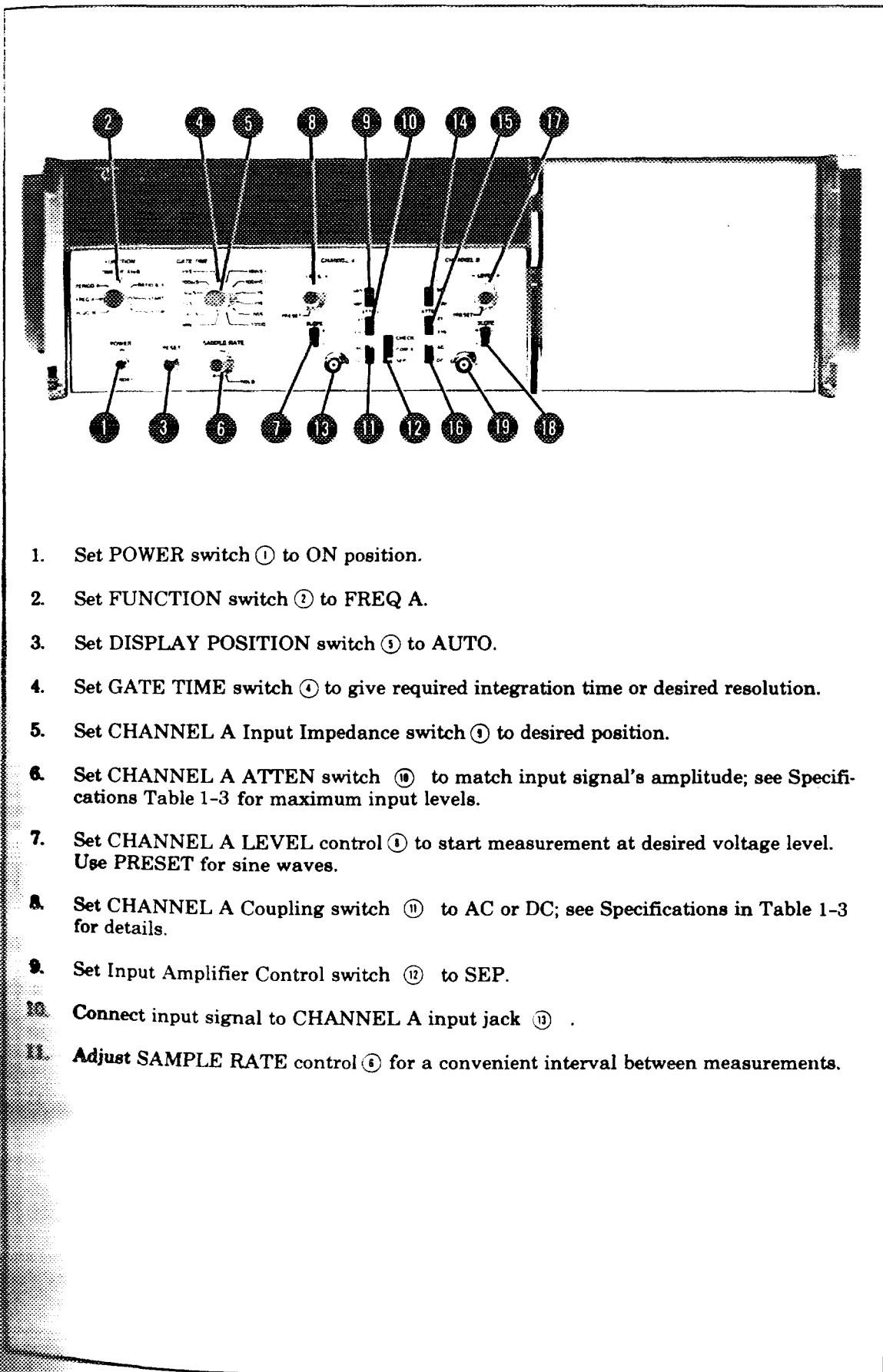

1. Set POWER switch ① to ON position.
2. Set FUNCTION switch ② to **FREQ A**.
3. Set DISPLAY POSITION switch ③ to **AUTO**.
4. Set GATE TIME switch ④ to give required integration time or desired resolution.
5. Set CHANNEL A Input Impedance switch ⑤ to desired position.
6. Set CHANNEL A ATTN switch ⑩ to match input signal's amplitude; see Specifications Table 1-3 for maximum input levels.
7. Set CHANNEL A LEVEL control ⑦ to start measurement at desired voltage level. Use **PRESET** for sine waves.
8. Set CHANNEL A Coupling switch ⑪ to **AC** or **DC**; see Specifications in Table 1-3 for details.
9. Set Input Amplifier Control switch ⑫ to **SEP**.
10. Connect input signal to CHANNEL A input jack ⑬ .
11. Adjust SAMPLE RATE control ⑥ for a convenient interval between measurements.

Figure 3-12. Frequency Measurements

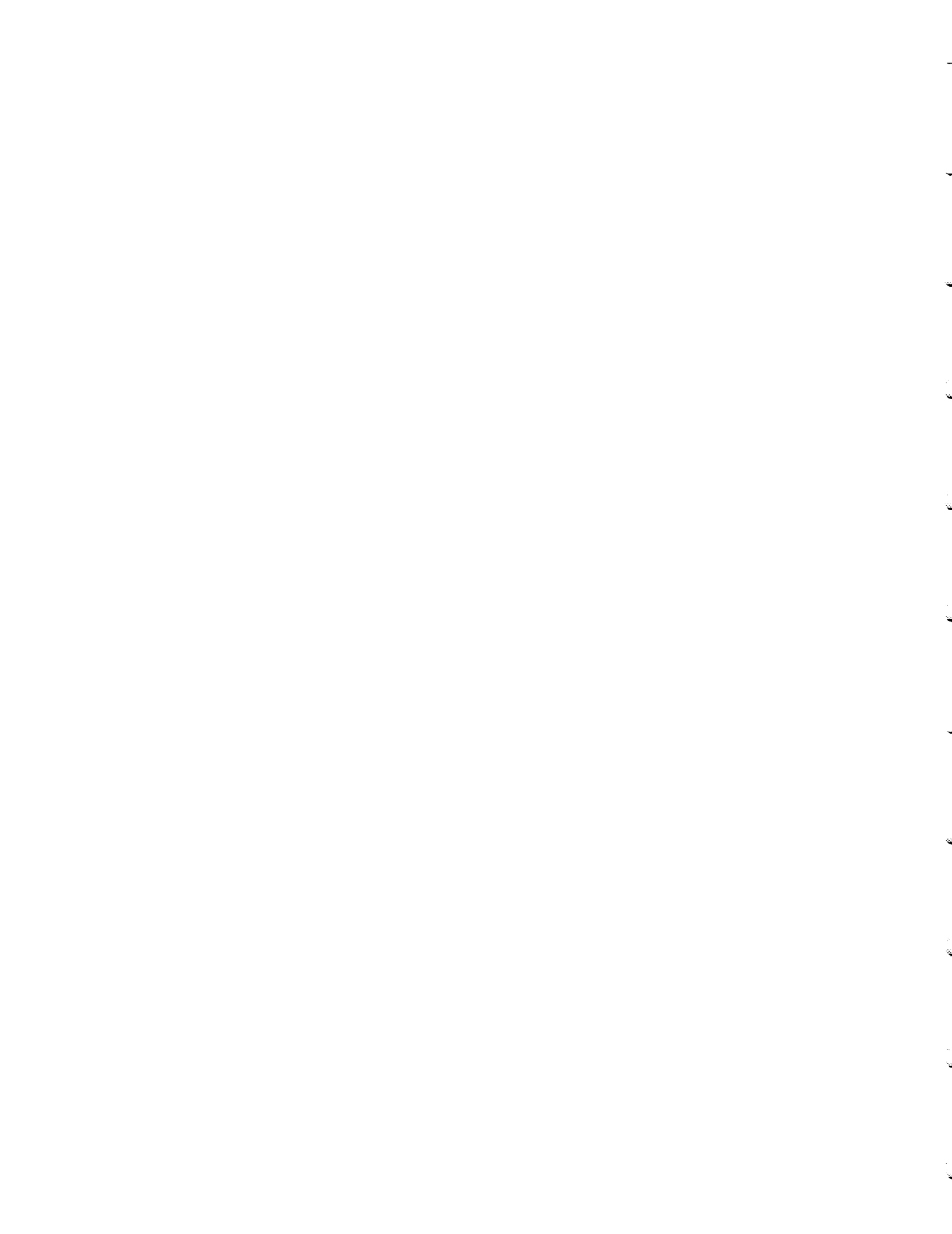

Model 5345A  
Operation

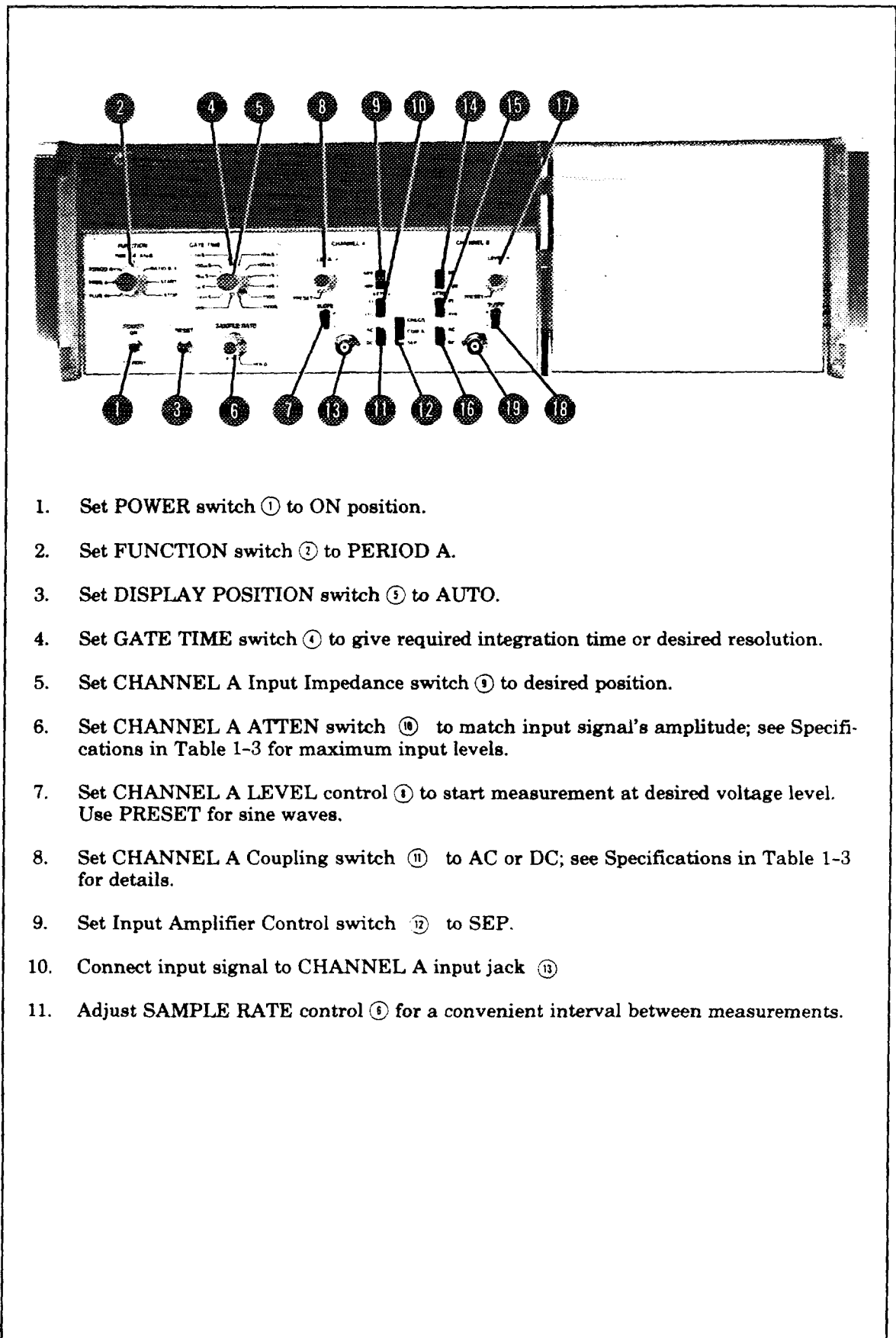

1. Set POWER switch ① to ON position.
2. Set FUNCTION switch ② to PERIOD A.
3. Set DISPLAY POSITION switch ③ to AUTO.
4. Set GATE TIME switch ④ to give required integration time or desired resolution.
5. Set CHANNEL A Input Impedance switch ⑤ to desired position.
6. Set CHANNEL A ATTEN switch ⑩ to match input signal's amplitude; see Specifications in Table 1-3 for maximum input levels.
7. Set CHANNEL A LEVEL control ⑦ to start measurement at desired voltage level. Use PRESET for sine waves.
8. Set CHANNEL A Coupling switch ⑪ to AC or DC; see Specifications in Table 1-3 for details.
9. Set Input Amplifier Control switch ⑫ to SEP.
10. Connect input signal to CHANNEL A input jack ⑬
11. Adjust SAMPLE RATE control ⑥ for a convenient interval between measurements.

Figure 3-13. Period Measurements

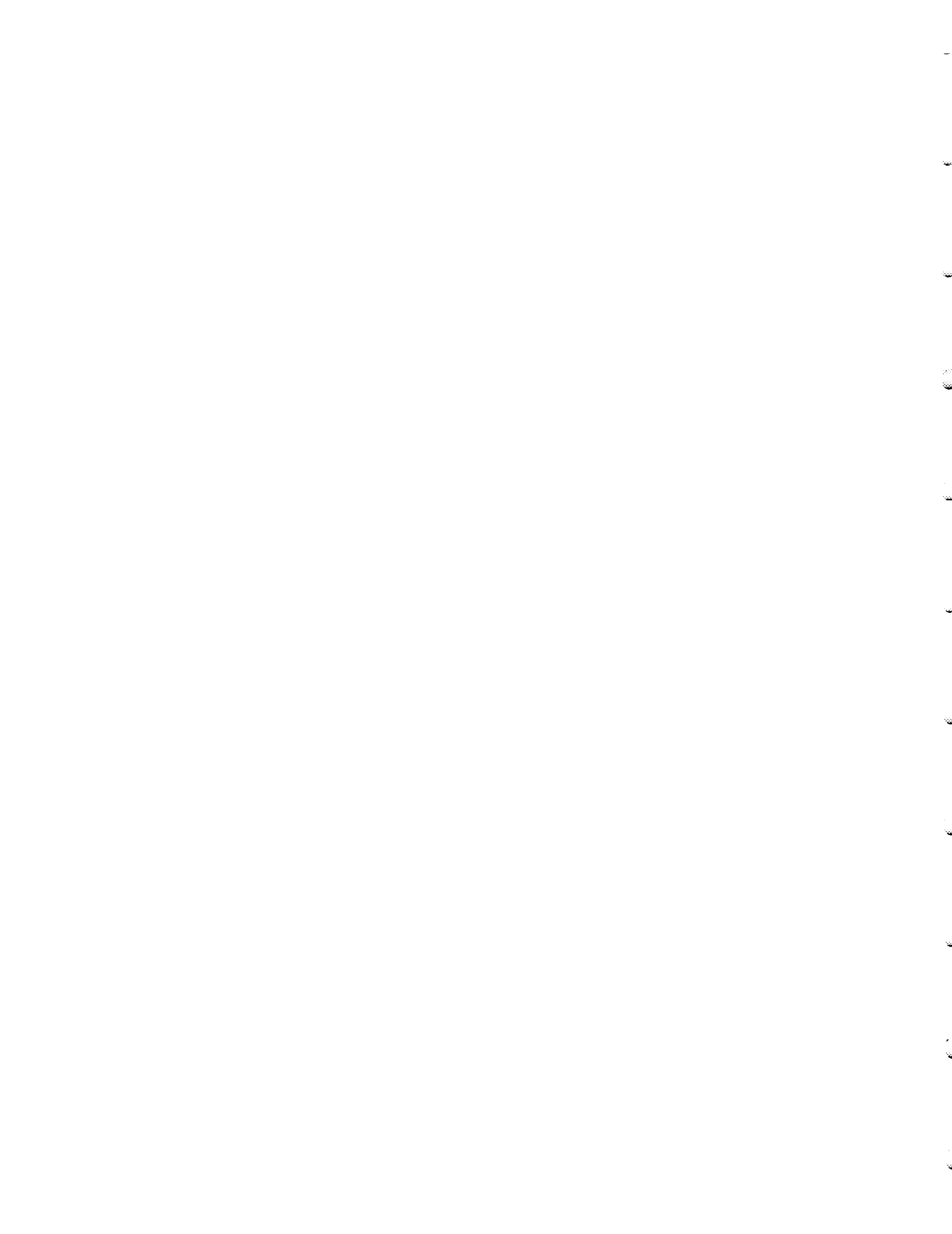



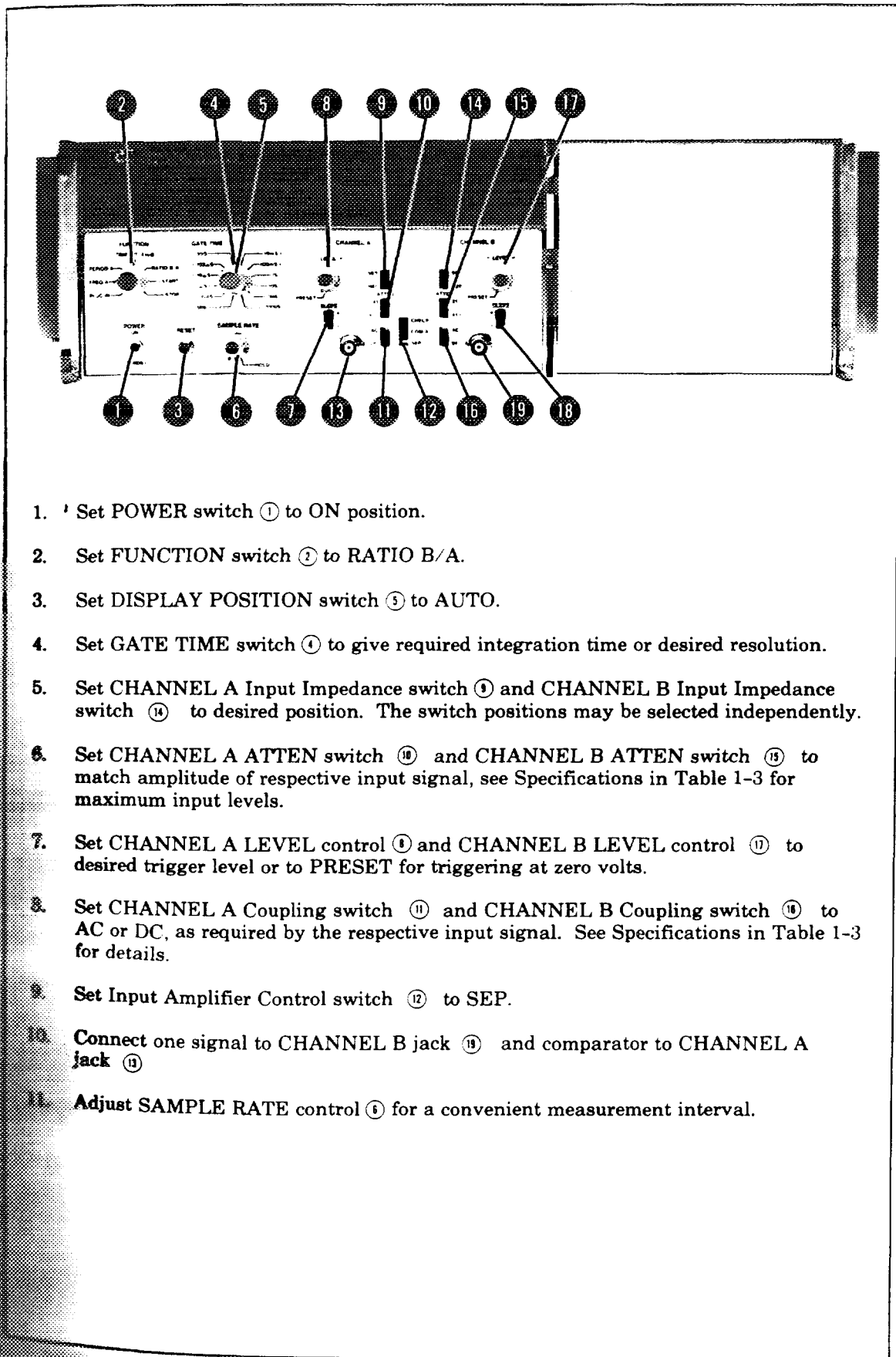

1. Set POWER switch ① to ON position.
2. Set FUNCTION switch ② to RATIO B/A.
3. Set DISPLAY POSITION switch ③ to AUTO.
4. Set GATE TIME switch ④ to give required integration time or desired resolution.
5. Set CHANNEL A Input Impedance switch ⑨ and CHANNEL B Input Impedance switch ⑩ to desired position. The switch positions may be selected independently.
6. Set CHANNEL A ATTEN switch ⑪ and CHANNEL B ATTEN switch ⑫ to match amplitude of respective input signal, see Specifications in Table 1-3 for maximum input levels.
7. Set CHANNEL A LEVEL control ⑬ and CHANNEL B LEVEL control ⑭ to desired trigger level or to PRESET for triggering at zero volts.
8. Set CHANNEL A Coupling switch ⑮ and CHANNEL B Coupling switch ⑯ to AC or DC, as required by the respective input signal. See Specifications in Table 1-3 for details.
9. Set Input Amplifier Control switch ⑰ to SEP.
10. Connect one signal to CHANNEL B jack ⑱ and comparator to CHANNEL A jack ⑲.
11. Adjust SAMPLE RATE control ⑥ for a convenient measurement interval.

Figure 3-14. Ratio Measurements

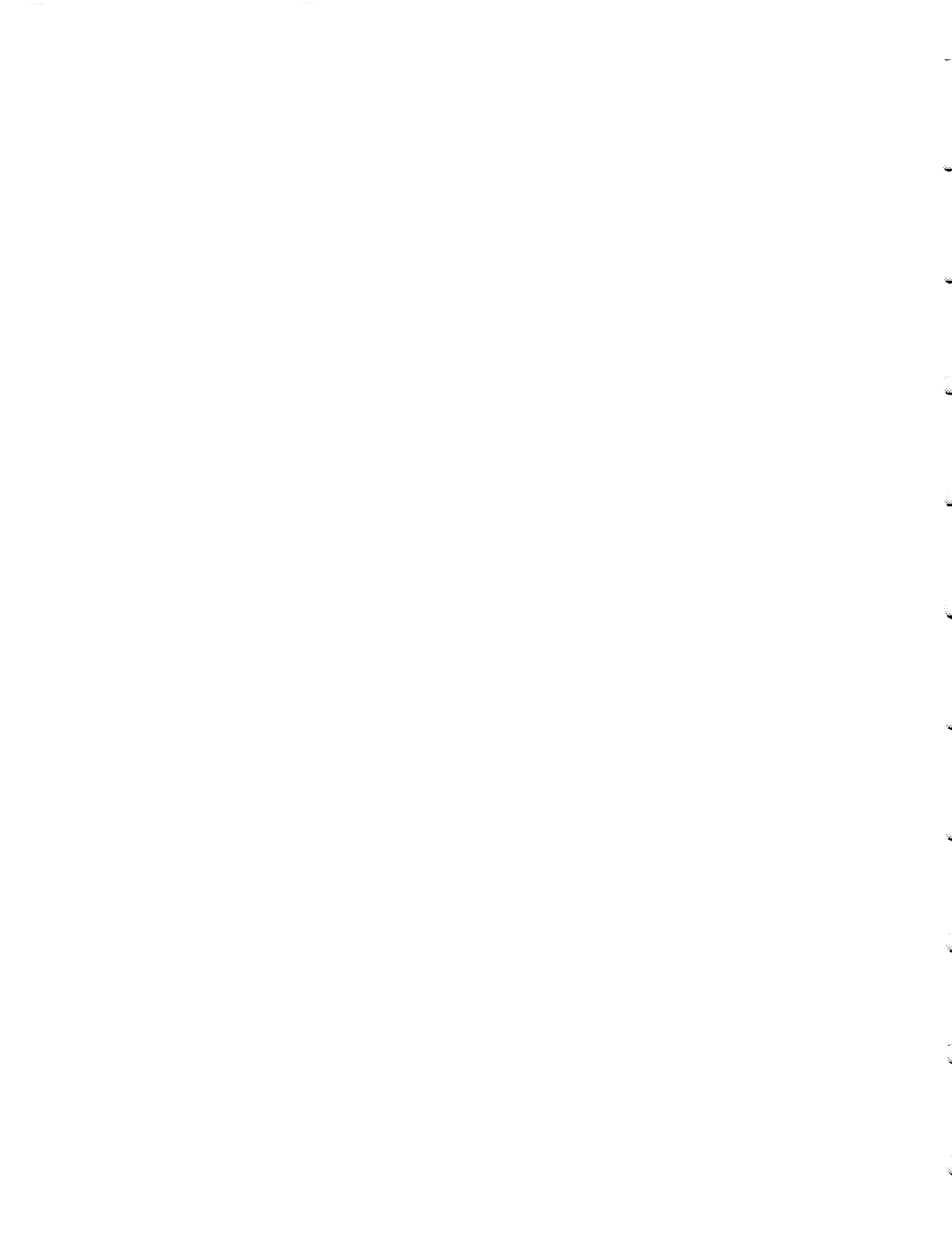

Model 5345A  
Operation

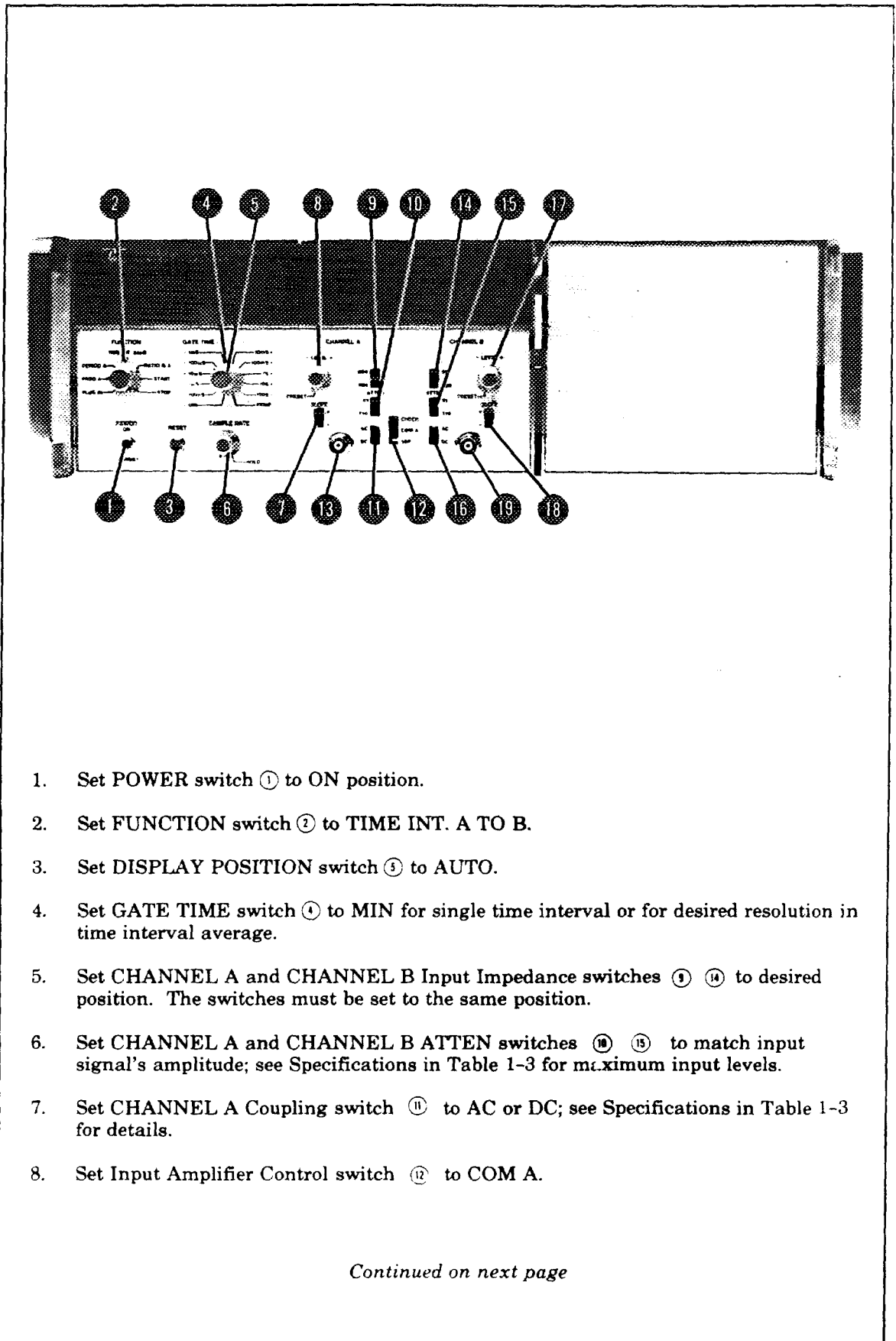

1. Set POWER switch ① to ON position.
2. Set FUNCTION switch ② to TIME INT. A TO B.
3. Set DISPLAY POSITION switch ③ to AUTO.
4. Set GATE TIME switch ④ to MIN for single time interval or for desired resolution in time interval average.
5. Set CHANNEL A and CHANNEL B Input Impedance switches ⑨ ⑭ to desired position. The switches must be set to the same position.
6. Set CHANNEL A and CHANNEL B ATTEN switches ⑩ ⑮ to match input signal's amplitude; see Specifications in Table 1-3 for maximum input levels.
7. Set CHANNEL A Coupling switch ⑪ to AC or DC; see Specifications in Table 1-3 for details.
8. Set Input Amplifier Control switch ⑫ to COM A.

*Continued on next page*

Figure 3-15. One Source Time Interval Measurements

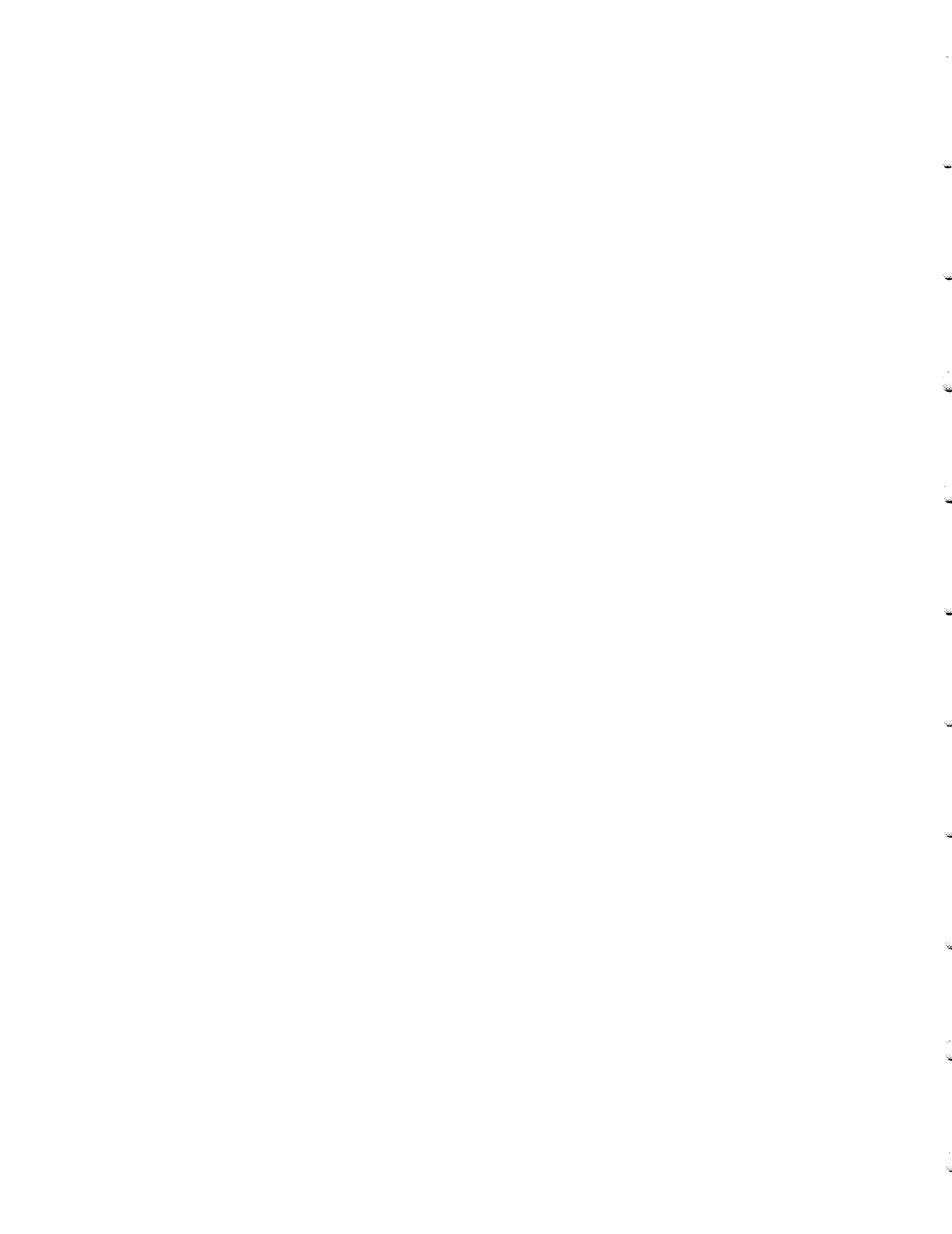

9. Connect input signal to CHANNEL A jack ⑬ .
10. Set CHANNEL A SLOPE switch ⑦ to + for triggering on positive slope or - for triggering on negative slope.
11. Set CHANNEL A LEVEL control ⑩ to start measurement at desired voltage level. Use CHAN A TRIG LEVEL output jack on rear panel to display starting point on an oscilloscope (if needed).
12. Set CHANNEL B SLOPE switch ⑧ to + for triggering on positive slope or - for triggering on negative slope.
13. Set CHANNEL B LEVEL control ⑪ to stop measurement at desired voltage level. Use CHAN B TRIG LEVEL output jack on rear panel to display stopping point on an oscilloscope (if needed).
14. Adjust SAMPLE RATE control ④ for convenient measurement interval.

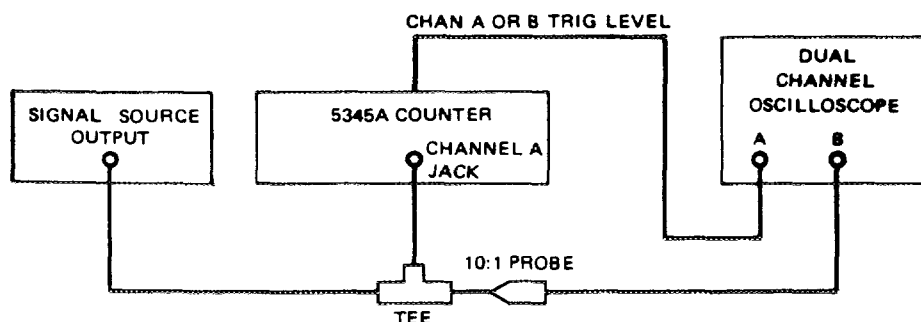
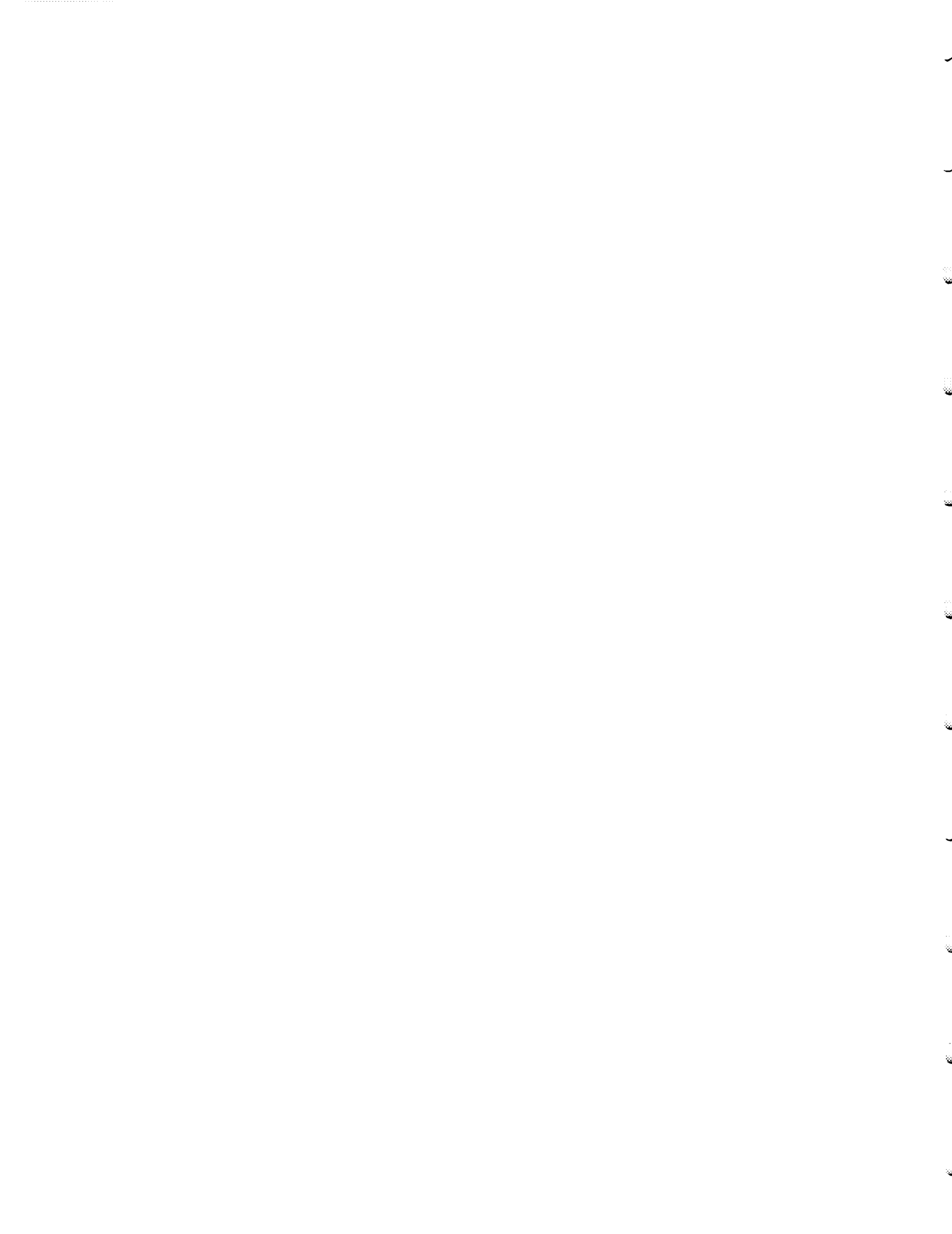
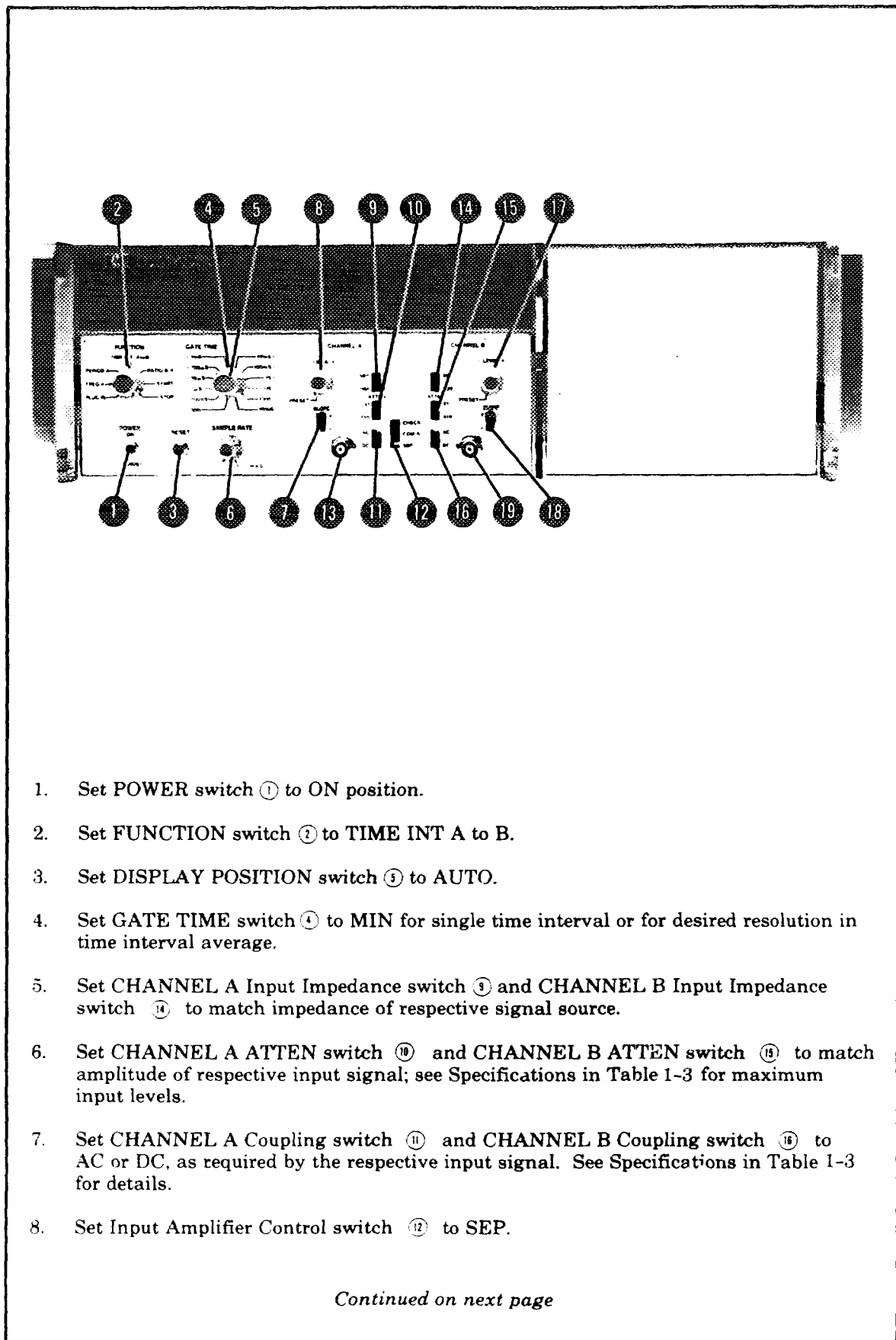

Figure 3-15. One Source Time Interval Measurements (Continued)



Model 5345A  
Operation



1. Set POWER switch ① to ON position.
2. Set FUNCTION switch ② to TIME INT A to B.
3. Set DISPLAY POSITION switch ③ to AUTO.
4. Set GATE TIME switch ④ to MIN for single time interval or for desired resolution in time interval average.
5. Set CHANNEL A Input Impedance switch ⑤ and CHANNEL B Input Impedance switch ⑥ to match impedance of respective signal source.
6. Set CHANNEL A ATTN switch ⑦ and CHANNEL B ATTN switch ⑧ to match amplitude of respective input signal; see Specifications in Table 1-3 for maximum input levels.
7. Set CHANNEL A Coupling switch ⑨ and CHANNEL B Coupling switch ⑩ to AC or DC, as required by the respective input signal. See Specifications in Table 1-3 for details.
8. Set Input Amplifier Control switch ⑪ to SEP.

*Continued on next page*

**Figure 3-16. Two Source Time Interval Measurements**

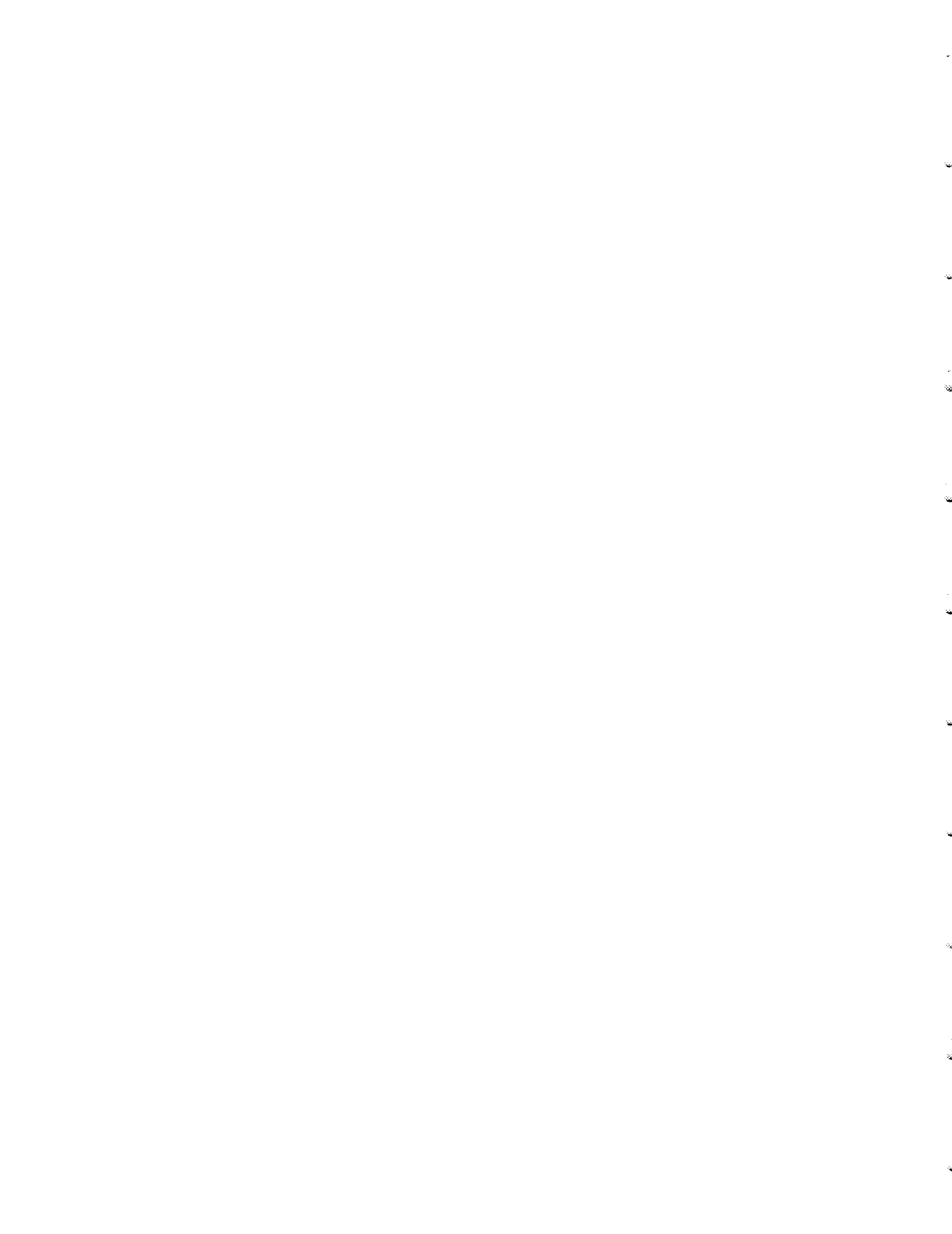



9. Connect start signal to CHANNEL A jack ⑬ and stop signal to CHANNEL B jack ⑭.
10. Set CHANNEL A SLOPE switch ⑦ to + for triggering on positive slope or to - for triggering on negative slope.
11. Set CHANNEL A LEVEL control ⑧ to start measurement at desired voltage level. Use CHAN A TRIG LEVEL output jack on rear panel to display starting point on an oscilloscope (if needed).
12. Set CHANNEL B SLOPE switch ⑩ to + for triggering on positive slope or - for triggering on negative slope.
13. Set CHANNEL B LEVEL control ⑪ to stop measurement at desired voltage level. Use CHAN B TRIG LEVEL output jack on rear panel to display stopping point on an oscilloscope (if needed).
14. Adjust SAMPLE RATE control ④ for a convenient measurement interval.

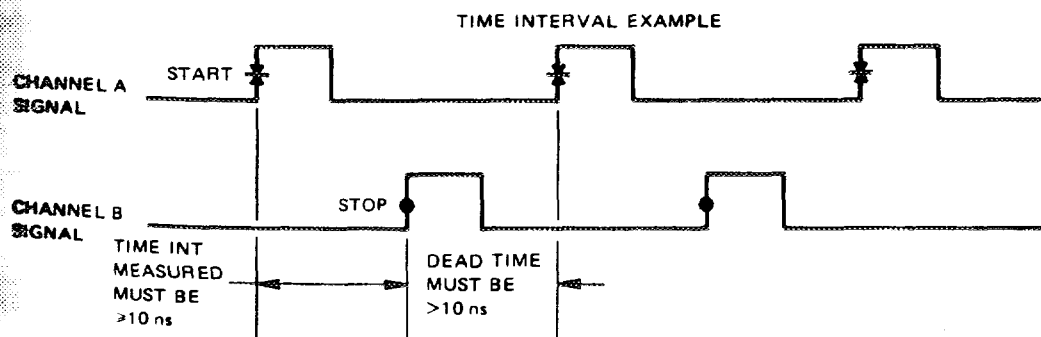
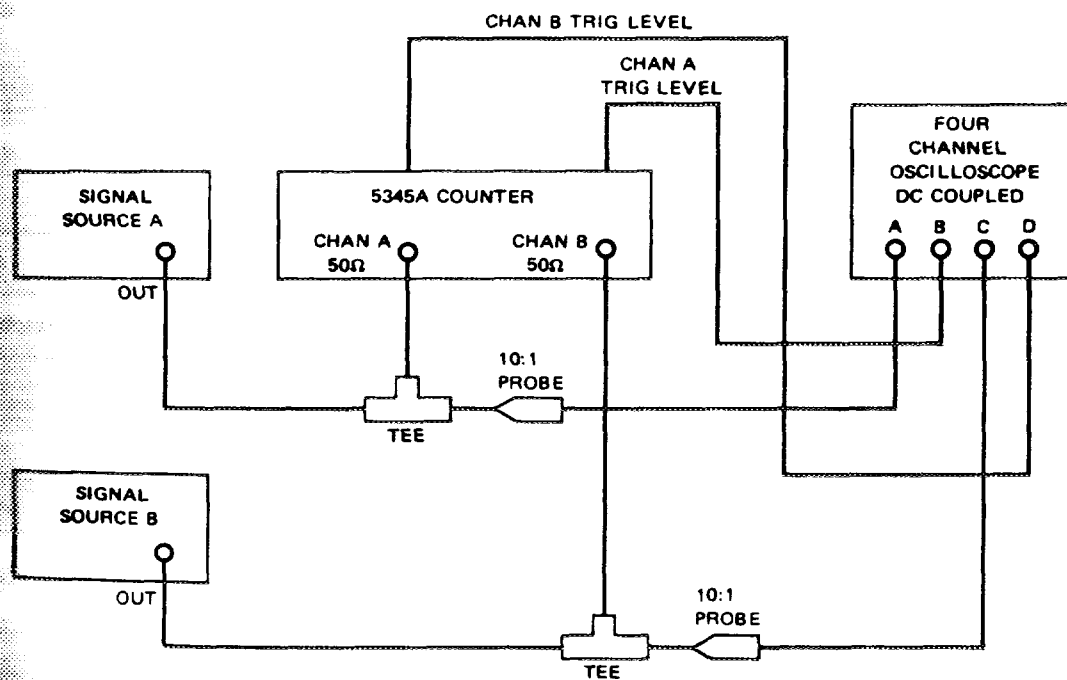
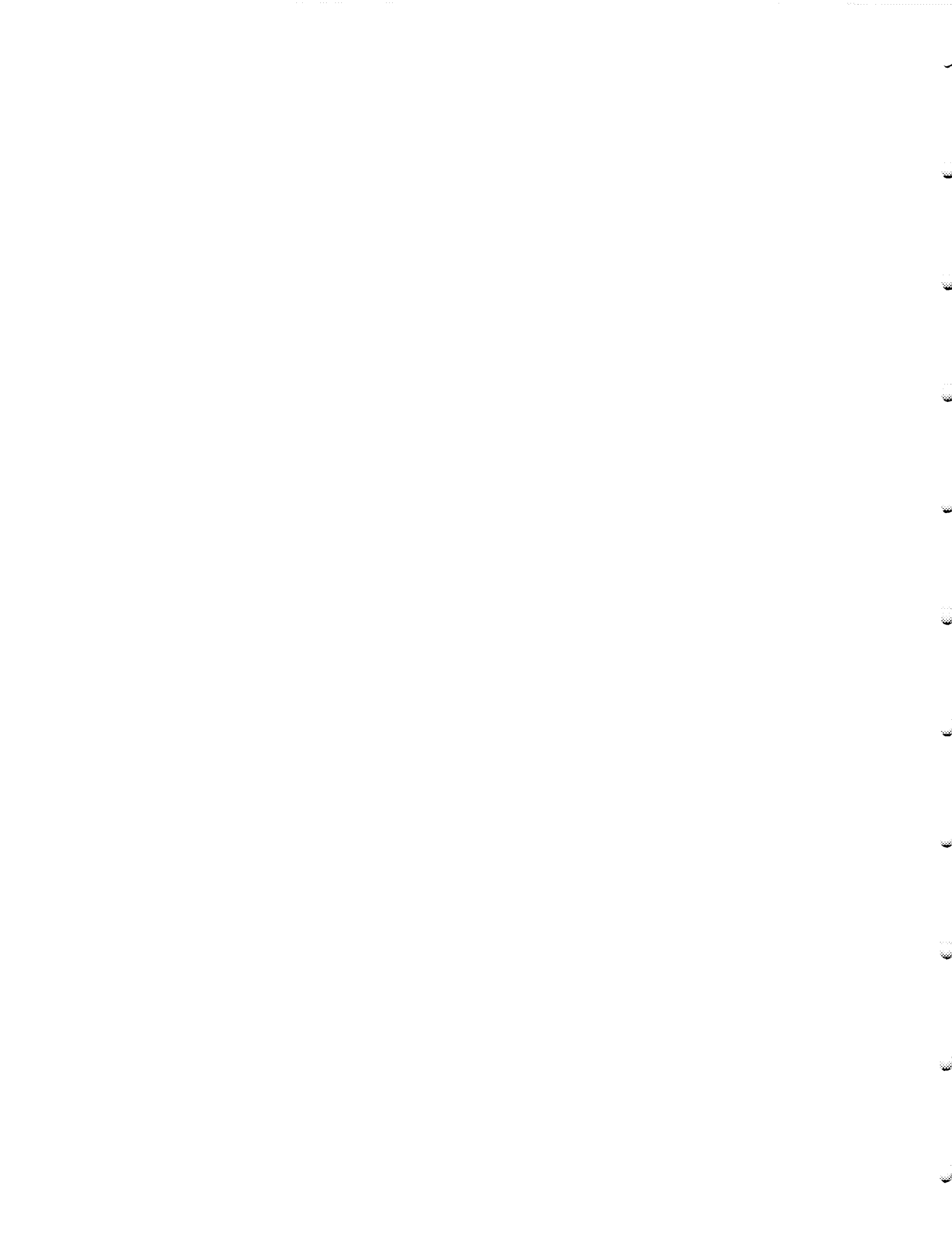
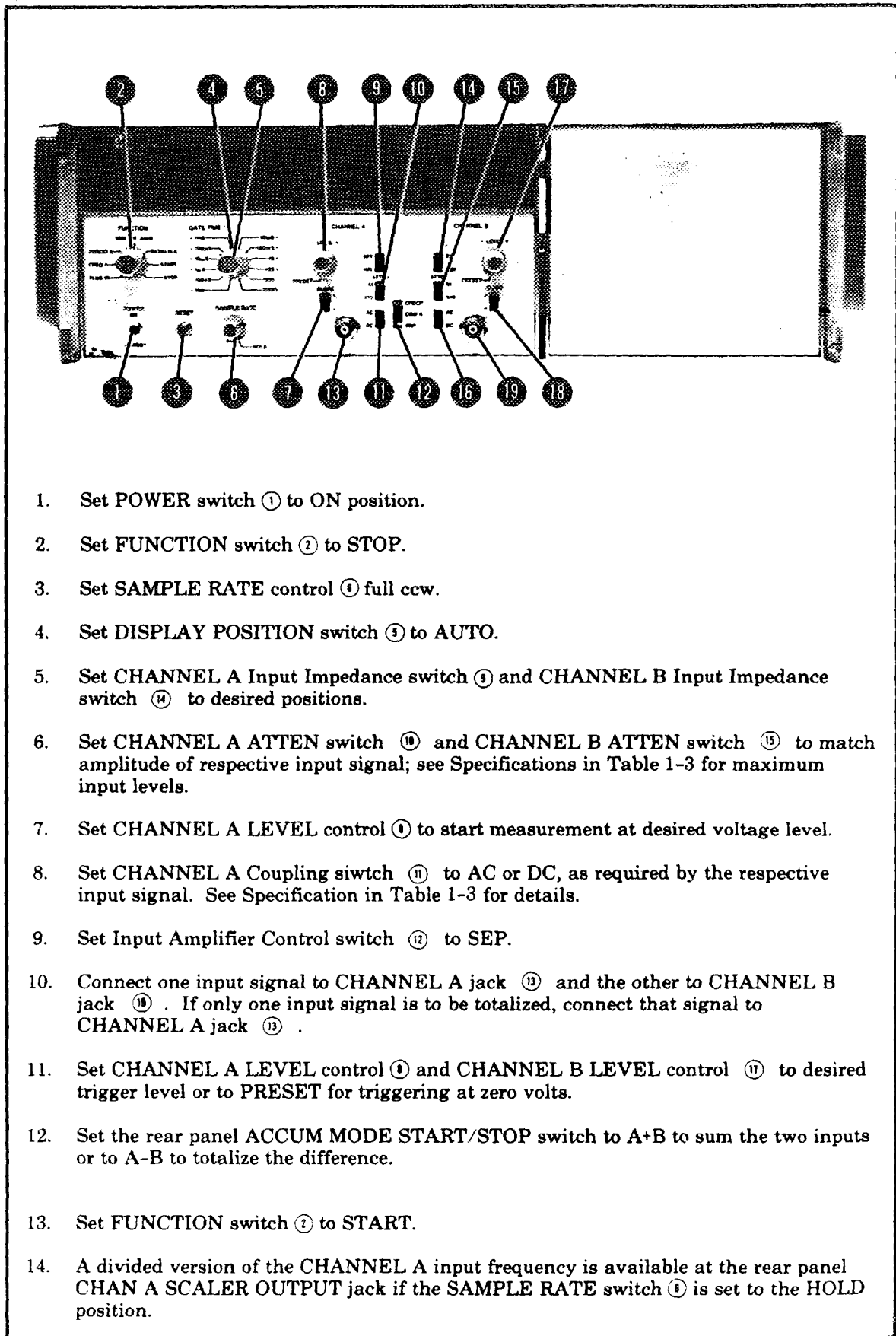

Figure 3-16. Two Source Time Interval Measurements (Continued)



Model 5345A  
Operation



1. Set POWER switch ① to ON position.
2. Set FUNCTION switch ② to STOP.
3. Set SAMPLE RATE control ④ full ccw.
4. Set DISPLAY POSITION switch ③ to AUTO.
5. Set CHANNEL A Input Impedance switch ⑨ and CHANNEL B Input Impedance switch ⑭ to desired positions.
6. Set CHANNEL A ATTEN switch ⑩ and CHANNEL B ATTEN switch ⑮ to match amplitude of respective input signal; see Specifications in Table 1-3 for maximum input levels.
7. Set CHANNEL A LEVEL control ⑧ to start measurement at desired voltage level.
8. Set CHANNEL A Coupling switch ⑪ to AC or DC, as required by the respective input signal. See Specification in Table 1-3 for details.
9. Set Input Amplifier Control switch ⑫ to SEP.
10. Connect one input signal to CHANNEL A jack ⑬ and the other to CHANNEL B jack ⑯. If only one input signal is to be totalized, connect that signal to CHANNEL A jack ⑬.
11. Set CHANNEL A LEVEL control ⑦ and CHANNEL B LEVEL control ⑰ to desired trigger level or to PRESET for triggering at zero volts.
12. Set the rear panel ACCUM MODE START/STOP switch to A+B to sum the two inputs or to A-B to totalize the difference.
13. Set FUNCTION switch ② to START.
14. A divided version of the CHANNEL A input frequency is available at the rear panel CHAN A SCALER OUTPUT jack if the SAMPLE RATE switch ④ is set to the HOLD position.

Figure 3-17. Totalize Measurements

